As filed with the Securities and Exchange Commission on February 9, 2022

**UNITED STATES
SECURITIES AND EXCHANGE COMMISSION
Washington, D.C. 20549**

**AMENDMENT NO. 1
TO
FORM S-1
REGISTRATION STATEMENT
UNDER
THE SECURITIES ACT OF 1933**

Forza X1, Inc.

(Exact name of Registrant as specified in its charter)

Delaware
(State or other jurisdiction of
incorporation or organization)

3730
(Primary Standard Industrial
Classification Code Number)

87-3159685
(I.R.S. Employer
Identification Number)

**3101 S. US-1
Ft. Pierce, Florida 34982
(772) 429-2525**

(Address, including zip code, and telephone number, including area code, of Registrant's principal executive offices)

**Joseph C. Visconti
Chairman and Chief Executive Officer
Forza X1, Inc.
3101 S. US-1
Ft. Pierce, Florida 34982
(772) 202-8039**

(Name, address, including zip code, and telephone number, including area code, of agent for service)

Copies to:

**Leslie Marlow, Esq.
Hank Gracin, Esq.
Patrick J. Egan, Esq.
Blank Rome LLP
1271 Avenue of the Americas
New York, New York 10020
(212) 885-5000**

**Gregory Sichenzia, Esq.
Jay Yamamoto, Esq.
Sichenzia Ross Ference LLP
1185 Avenue of the Americas, 31st Floor
New York, New York 10036
Tel: (212) 930-9700**

Approximate date of commencement of proposed sale to the public: As soon as practicable after the effective date of this registration statement.

If any of the securities being registered on this form are to be offered on a delayed or continuous basis pursuant to Rule 415 under the Securities Act of 1933, check the following box.

If this form is filed to register additional securities for an offering pursuant to Rule 462(b) under the Securities Act, please check the following box and list the Securities Act registration statement number of the earlier effective registration statement for the same offering.

If this form is a post-effective amendment filed pursuant to Rule 462(c) under the Securities Act, check the following box and list the Securities Act registration statement number of the earlier effective registration statement for the same offering.

If this form is a post-effective amendment filed pursuant to Rule 462(d) under the Securities Act, check the following box and list the Securities Act registration statement number of the earlier effective registration statement for the same offering.

Indicate by check mark whether the registrant is a large accelerated filer, an accelerated filer, a non-accelerated filer, smaller reporting company or an emerging growth company. See the definitions of "large accelerated filer," "accelerated filer," "smaller reporting company" and "emerging growth company" in Rule 12b-2 of the Exchange Act.

Large accelerated filer

Accelerated filer

Non-accelerated filer

Smaller reporting company

Emerging growth company

If an emerging growth company, indicate by check mark if the registrant has elected not to use the extended transition period for complying with any new or revised financial accounting standards provided pursuant to Section 7(a)(2)(B) of the Securities Act.

The Registrant hereby amends this Registration Statement on such date or dates as may be necessary to delay its effective date until the Registrant shall file a further amendment which specifically states that this Registration Statement shall thereafter become effective in accordance with Section 8(a) of the Securities Act of 1933, as amended, or until the Registration Statement shall become effective on such date as the Securities and Exchange Commission, acting pursuant to said Section 8(a), may determine.

The information contained in this preliminary prospectus is not complete and may be changed. These securities may not be sold until the registration statement filed with the Securities and Exchange Commission is effective. This preliminary prospectus is not an offer to sell these securities and it is not soliciting an offer to buy these securities in any state where the offer or sale is not permitted.

PRELIMINARY PROSPECTUS

SUBJECT TO COMPLETION

DATED FEBRUARY , 2022

Shares Common Stock



Forza X1, Inc.

This is a firm commitment initial public offering of shares of common stock of Forza X1, Inc. We are offering shares of our common stock. We anticipate that the initial public offering price of our shares will be between \$ and \$ per share. The underwriters have informed us that the gross proceeds of this offering will not be less than \$.

Prior to this offering, there has been no public market for our common stock. We intend to apply to list our shares of common stock on The Nasdaq Capital Market under the symbol "FRZA." No assurance can be given that our application will be approved. The closing of this offering is contingent upon the successful listing of our common stock on the Nasdaq Capital Market.

We are an "emerging growth company" under the federal securities laws and have elected to comply with certain reduced public company reporting requirements.

Investing in our common stock involves a high degree of risk. See "Risk Factors" beginning on page 10. Neither the Securities and Exchange Commission nor any state securities commission has approved or disapproved of these securities or determined if this prospectus is truthful or complete. Any representation to the contrary is a criminal offense.

	Per Share	Total
Initial Public offering price	\$	\$
Underwriting discounts and commissions(1)	\$	\$
Proceeds to us, before expenses	\$	\$

(1) Underwriting discounts and commissions do not include a non-accountable expense allowance equal to 1.0% of the initial public offering price payable to the underwriters. We refer you to "Underwriting" beginning on page 98 for additional information regarding underwriters' compensation.

We have granted a 45-day option to the representative of the underwriters to purchase up to additional shares of common stock solely to cover over-allotments, if any.

The underwriters expect to deliver the shares to purchasers on or about , 2022.

ThinkEquity

The date of this prospectus is , 2022



PICTURES SHOWN ARE GRAPHIC REPRESENTATIONS OF OUR FX1 MODELS. THERE MAY BE ADDITIONAL CHANGES OR ALTERATIONS TO OUR BOATS AS WE MOVE FROM THE DESIGN AND PROTOTYPE PHASE TO THE PRODUCTION AND MANUFACTURING PHASE. TO DATE, WE HAVE NOT PRODUCED OR SOLD ANY ELECTRIC BOATS.



 **FORZA X1**



PICTURES SHOWN ARE GRAPHIC REPRESENTATIONS OF OUR FX1 MODELS. THERE MAY BE ADDITIONAL CHANGES OR ALTERATIONS TO OUR BOATS AS WE MOVE FROM THE DESIGN AND PROTOTYPE PHASE TO THE PRODUCTION AND MANUFACTURING PHASE. TO DATE, WE HAVE NOT PRODUCED OR SOLD ANY ELECTRIC BOATS.



 FORZA X1

Sustainability has
Found the Water



PICTURES SHOWN ARE GRAPHIC REPRESENTATIONS OF OUR FX1 MODELS. THERE MAY BE ADDITIONAL CHANGES OR ALTERATIONS TO OUR BOATS AS WE MOVE FROM THE DESIGN AND PROTOTYPE PHASE TO THE PRODUCTION AND MANUFACTURING PHASE. TO DATE, WE HAVE NOT PRODUCED OR SOLD ANY ELECTRIC BOATS.



PICTURES SHOWN ARE GRAPHIC REPRESENTATIONS OF OUR FX1 MODELS. THERE MAY BE ADDITIONAL CHANGES OR ALTERATIONS TO OUR BOATS AS WE MOVE FROM THE DESIGN AND PROTOTYPE PHASE TO THE PRODUCTION AND MANUFACTURING PHASE. TO DATE, WE HAVE NOT PRODUCED OR SOLD ANY ELECTRIC BOATS.

Achieving
the
Sustainable
Future
Today



PICTURES SHOWN ARE GRAPHIC REPRESENTATIONS OF OUR FX1 MODELS. THERE MAY BE ADDITIONAL CHANGES OR ALTERATIONS TO OUR BOATS AS WE MOVE FROM THE DESIGN AND PROTOTYPE PHASE TO THE PRODUCTION AND MANUFACTURING PHASE. TO DATE, WE HAVE NOT PRODUCED OR SOLD ANY ELECTRIC BOATS.

TABLE OF CONTENTS

Prospectus

Trademarks	i
Special Note Regarding Forward-Looking Statements	ii
Market, Industry and Other Data	ii
Prospectus Summary	1
The Offering	8
Summary Financial Data	9
Risk Factors	10
Use of Proceeds	36
Dividend Policy	37
Capitalization	38
Dilution	39
Management's Discussion and Analysis of Financial Condition and Results of Operations	41
Business	47
Management	69
Executive Compensation	78
Certain Relationships and Related Party Transactions	85
Principal Stockholders	87
Description of Capital Stock	88
Shares Eligible for Future Sale	93
Material U.S. Federal Income Tax Considerations for Non-U.S. Holders of Our Common Stock	95
Underwriting	99
Legal Matters	107
Experts	107
Where You Can Find Additional Information	107
Disclosure of Commission Position on Indemnification for Securities Act Liabilities	107
Index to Financial Statements	F-1

We and the underwriters have not authorized anyone to provide you any information other than that contained in this prospectus or in any free writing prospectus prepared by or on behalf of us or to which we have referred you, and you should rely only on the information contained in this prospectus or in any such free writing prospectus. We take no responsibility for, and can provide no assurance as to the reliability of, any other information that others may give you. We and the underwriters are not making an offer to sell nor a solicitation of any offer to buy these securities in any jurisdiction where the offer or sale is not permitted. You should assume that the information appearing in this prospectus is accurate only as of the date on the front cover of this prospectus. Our business, financial condition, results of operations and prospects may have changed since that date.

For investors outside of the United States: we have not and the underwriters have not done anything that would permit this offering or possession or distribution of this prospectus in any jurisdiction where action for that purpose is required, other than the United States. Persons outside of the United States who come into possession of this prospectus must inform themselves about, and observe any restrictions relating to, the offering of the shares of common stock and the distribution of this prospectus outside of the United States.

TRADEMARKS

We own directly, or have rights to, trademarks, service marks, and trade names that we use in connection with operation of our business, such as Forza X1. In addition, our names, logos, and website names and addresses are our service marks or trademarks. Other trademarks, service marks, and trade names appearing in this prospectus are the property of their respective owners. Solely for convenience, the trademarks, service marks, trade names, and copyrights referred to in this prospectus are listed without the ©, ®, and ™ symbols, but we will assert, to the fullest extent under applicable law, our rights, the rights of our parent company, or the rights of the applicable licensors to these trademarks, service marks, and trade names.

SPECIAL NOTE REGARDING FORWARD-LOOKING STATEMENTS

This prospectus contains “forward-looking statements.” We use words such as “could,” “may,” “might,” “will,” “expect,” “likely,” “believe,” “continue,” “anticipate,” “estimate,” “intend,” “plan,” “project,” and other similar expressions to identify some forward-looking statements, but not all forward-looking statements include these words. All of our forward-looking statements involve estimates and uncertainties that could cause actual results to differ materially from those expressed in the forward-looking statements. Accordingly, any such statements are qualified in their entirety by reference to the information described under the caption “Risk Factors” and elsewhere in this prospectus.

The forward-looking statements contained in this prospectus are based on assumptions that we have made in light of our industry experience and our perceptions of historical trends, current conditions, expected future developments, and other factors we believe are appropriate under the circumstances. As you read and consider this prospectus, you should understand that these statements are not guarantees of performance or results. They involve risks, uncertainties (many of which are beyond our control), and assumptions. Although we believe that these forward-looking statements are based on reasonable assumptions, you should be aware that many factors could affect our actual operating and financial performance and cause our performance to differ materially from the performance anticipated in the forward-looking statements. We believe these factors include, but are not limited to, those described under “Risk Factors” and “Management’s Discussion and Analysis of Financial Condition and Results of Operations.” Should one or more of these risks or uncertainties materialize, or should any of these assumptions prove incorrect, our actual operating and financial performance may vary in material respects from the performance projected in these forward-looking statements.

Further, any forward-looking statement speaks only as of the date on which it is made, and except as required by law, we undertake no obligation to update any forward-looking statement contained in this prospectus to reflect events or circumstances after the date on which it is made or to reflect the occurrence of anticipated or unanticipated events or circumstances. New factors that could cause our business not to develop as we expect emerge from time to time, and it is not possible for us to predict all of them. Further, we cannot assess the impact of each currently known or new factor on our results of operations or the extent to which any factor, or combination of factors, may cause actual results to differ materially from those contained in any forward-looking statements.

MARKET, INDUSTRY AND OTHER DATA

This prospectus includes market and industry data and forecasts that we have derived from independent consultant reports, publicly available information, various industry publications, such as those of the National Marine Manufacturers Association, or NMMA, and Statistical Surveys, Inc., or SSI, other published industry sources, and our internal data and estimates.

Our internal data and estimates are based upon information obtained from trade and business organizations and other contacts in the markets in which we operate and our management’s understanding of industry conditions. Although we believe that such information is reliable, we have not had this information verified by any independent sources.

PROSPECTUS SUMMARY

This summary highlights selected information that is presented in greater detail elsewhere in this prospectus. This summary does not contain all of the information you should consider before investing in our common stock. You should read this entire prospectus carefully, including the sections titled “Risk Factors” and “Management’s Discussion and Analysis of Financial Condition and Results of Operations” and our audited financial statements and the related notes included elsewhere in this prospectus, before making an investment decision. Unless the context otherwise requires, the terms “Forza X1,” “the Company,” “we,” “us” and “our” in this prospectus refer to Forza X1, Inc.

Overview

About Forza X1

Forza X1, Inc. (“Forza X1” “we” “us” or the “Company”) aims to be among the first to develop and manufacture electric boats targeting the recreational market. Our mission is to inspire the adoption of sustainable recreational boating by producing stylish electric sport boats. We are focused on the creation and implementation of marine electric vehicle (“EV”) technology to control and power our electric boats utilizing our proprietary outboard electric motor. Our electric boats are being designed as fully integrated electric boats including the hull, outboard motor and control system.

To date, we have completed the design of the hull and running surface of the boat and have begun tooling the molds which are required to build the physical fiberglass boat, we have entered into a supply agreement for the supply of the lithium battery packs that we plan to use to power the electric boats, completed the design and prototyping of the boat control system, and completed the design and are halfway through prototyping of the electric outboard motor. We expect to begin production of our FX1 fully integrated electric boat and motor and commence selling to end user customers by the second quarter of 2023.

We currently anticipate using the net proceeds from this offering, together with our existing resources, as follows: (i) \$ for the design, development, testing, production and marketing of our electric boats; (ii) \$ for the design, development, testing, production and marketing of our electric outboard motors; (iii) \$ for the design, development, testing, manufacturing of our integrated control system; (iv) \$ for the acquisition of property and the development of a manufacturing plant to build, design and manufacture our new line of electric boats; (v) \$ for the development of a vertically integrated direct-to-consumer distribution platform; and (vi) \$ working capital. See the section titled “Use of Proceeds” for additional information.

We believe that the boating industry will follow in the footsteps of the electrification of the automotive industry by creating electric boats that meet or exceed the traditional boating consumers expectations of price, value and run times. In other words, electric boats must offer a similar experience when compared to traditional gas-powered boat in terms of size, capability and price point.

We currently are a wholly-owned subsidiary of Twin Vee Powercats Co. Prior to our incorporation in October 2021, we operated as the Electra Power Sports™ Division of Twin Vee. With increased indications of interest received by Twin Vee for electric vehicles, Twin Vee determined that we should be a stand-alone entity and transferred the entirety of its electric boat business to us.

To date, Forza X1 has received \$2,000,000 in capital contributions from Twin Vee which funds we have used for the design, development, testing, production and marketing of our electric boats and electric outboard motors. Until such time as we receive proceeds from this offering or we generate revenue from the sale of our electric boats, we anticipate that we will continue to receive and rely on funding from Twin Vee.

First FX1 Models

Our initial two models, the FX1 Dual Console and FX1 Center Console, are being designed to be 24-foot in length, have an 8’ beam or width and utilize a catamaran hull surface to reduce drag and increase run times. The initial launch of FX1 will include our proprietary single electric outboard motor. Both FX1 models are being designed with advanced high-powered, liquid-cooled battery packs that will be provided by the third party supplier with whom we have entered into a five year supply agreement and a vehicle control unit with proprietary control software all integrated into a 22” master control touch screen that will be used to control most functions of the boat. We have also filed three design and four utility patent applications with the U.S. Patent and Trademark Office relating to, among other things, our propulsion system being developed and boat design.

Forza X1: An All Digital, Direct-to-Consumer Platform

We intend to offer our EV products, services and support through a Web-based and mobile phone App that will be vertically integrated and a direct-to-consumer platform. Over the last couple of years, non-contact consumerism has brought shopping and customer service experiences to a new level that will likely remain prevalent long after the COVID-19 pandemic. We intend to create a high quality customer experience that spans the entire life of our products through an online system that is being designed to be comprehensive, seamless, and efficient for a customer experience.

Forza X1 plans to utilize a web-based and app platform to connect with customers for an end-to-end experience encompassing everything from buying, financing, delivery, servicing, and training. We have commenced the design of the web-based platform but have not yet commenced design of the app. This customer-centric approach to sales and service aims at simplifying access to necessary information for potential buyers and current owners alike. Customers will be able to communicate directly with Forza X1 to ensure their questions are answered and their needs are met.

Currently, Forza X1’s web and app-based platform is expected to include the following:

- **Build and Price Boats.** The web and app platform will offer prospective buyers a place to examine photos and videos of our boats, which will all have a single price based on the model type and a few available options. For example, the consumer would have four gel coat exterior choices, three interior upholstery choices, and an option to increase the battery pack capacity for extended run times. Other options would include charging cords and plugs, boating items such as bumpers, covers, and fun add-ons like clothing, allowing consumers to “personalize” their Forza X1 purchase.

- **Financing.** Prospective customers will be able to apply for third-party consumer financing to complete or supplement their purchase through Forza X1’s web and app platform.
- **Delivery.** Once manufactured, the boat will be delivered directly to a customer’s home, marina, or wherever they choose. The scheduling, communication, and support necessary for coordinating touchless delivery of our Forza X1 boats would all be accomplished over the website or app.

- **Service.** We intend to offer highly tailored and differentiated services that enable intuitive experiences throughout the entire customer lifecycle, such as warranty, repair, or other service assistance for their boats. We expect this all-inclusive approach will provide higher customer satisfaction, create strong brand loyalty, and increase operational efficiency while simultaneously allowing us to capture a more significant share of the entire lifecycle value of every Forza X1 boat produced. We anticipate having internal staff with the capability to provide an over the air (“OTA”) update to resolve the issue remotely without the boat ever leaving the customer’s sight. As part of our customer satisfaction drive, we plan for our staff to make mobile service calls to the boat docks. We also intend to enter into partnering arrangements with third parties to address service needs that require more than a mobile service visit, and we plan to arrange for the boat to be picked up and brought to one of our partnered service centers. If a service center is not available in a customer’s area, then Forza X1 will permit the owners to take their boat to their local service center who will then invoice us.
- **Customer Service and Feedback.** We will utilize customer insights and feedback submitted via our web and app-based platform to improve our offerings by adding new capabilities and functionality. Expanded offerings based on consumer-driven feedback and data is expected to attract more customers, deepen existing customer relationships, and allow us to innovate more quickly.
- **Training.** Forza X1 intends to provide a series of videos that demonstrate our boats’ safe operation and upkeep. These videos would be accessible on our web and app platform and the boat’s onboard computer for quick access.

Forza X1 Purpose

According to the Environmental Energy Student Institute, a non-profit organization originally formed by a bipartisan group of members of Congress, fossil fuels, including coal, oil, and natural gas, have been powering economies for over 150 years and currently supply about 80 percent of the world’s energy. When fossil fuels are burned, the stored carbon and other greenhouse gases are released into the atmosphere. The excess buildup of greenhouse gases in the atmosphere has caused dramatic changes to Earth’s climate—a trend that will worsen as more fossil fuels are burned. Further climate changes may cause rises in sea level, extreme weather, biodiversity loss, and species extinction, as well as food scarcity, worsening health, and poverty for millions of people worldwide.

The world’s waterways are also in danger from pollutants caused by gas-powered motors. In the landmark environmental study and book, “Polluting for Pleasure”, author Andre Mele stated that recreational boats, particularly outboards, were polluting as much as all the cars and trucks in America. At the time, Mele discovered that pleasure boats have polluted 80 times more than automobile engines and put more oil into American waters than 15 Exxon Valdez oil spills, annually. The popularity of recreational boating has grown since then.

While headway is being made by the automotive industry introducing more viable EV options to replace traditional automobiles, it is also vital that we look to preserve our waterways while reducing carbon emissions. Large gas-powered engines often leak fuel and produce carbon emissions, both of which are harmful to fragile marine ecosystems. Forza X1 is a company comprised of people who are passionate to move the preservation and carbon free marine lifestyle forward. According to the Bloomberg NEF’s 2021 Electric Vehicle Outlook, passenger automotive EV sales are set to increase from 3.1 million units in 2020 to 14 million units in 2025.

Forza X1 aims to manufacture electric boats that will be environmentally friendly with a proprietary electric outboard motor that has been designed and integrated with our own control system. The Forza X1 boats are being designed for the production of a combined boat and motor package, along with our control system that we intend to market and sell as a single package. Our Forza X1 boat is intended to work seamlessly and offer families and water recreation enthusiasts an enjoyable time for an affordable price.

Our core market corresponds most directly to those who identify with environmentally friendly vehicles. Electric boats promote environmental sustainability and allow for a much more serene and enjoyable time on the water. The adoption of electric vehicles has increased considerably over the years as they are more environmentally friendly. As per the report by Bloomberg NEF, there are currently 12 million passenger EVs on the road, and the prevalence of electric-powered boats is likely to follow suit. While electric boats only represented about 2% of the market in 2020, a report by IDTechEx estimates that the market for hybrid and pure electric boats is expected to rise rapidly to greater than \$20 billion worldwide by 2027, finding that recreational boats is the largest and fastest growing electric marine market in sales number.

Forza X1 plans to disrupt recreational marine customs that rely on outdated processes and noxious engines by designing, engineering and manufacturing inspiring electric boats that operate in a more sustainable and eco-friendly way.

Our Strengths and Competitive Advantages

We believe that the following are the critical investment attributes of our company:

- **Assembling a Technology, Engineering and Manufacturing Team.** We continue to build and add valuable, experienced and knowledgeable team members. Jim Leffew, our President, comes to us from Maverick Boat Group, Inc. that was recently sold to Malibu Boats. Jim Leffew has been designing, building and manufacturing boats on a large-scale basis for over 25 years. The year Maverick Boat Group was sold to Malibu Boats, Jim Leffew was overseeing the manufacturing and Maverick Boat Group was building and selling over 1,400 boats annually. The experience and knowledge that Jim Leffew brings to the table is expected to be valuable to the requirements of designing and ramping up our manufacturing facility.
- **Singular Focus and Leadership in Electric Powertrain Technology.** We intend to establish a first-mover advantage that would enable us to establish strong brand recognition and product/service loyalty before potential competing companies enter the market. Forza X1 is focused exclusively on developing our electric boats and electric powertrain technology to achieve a compelling combination of range and performance. We intend to use our electric powertrain expertise to innovate rapidly and sustain technological and time-to-market advantages over other marine manufacturers.
- **Combination of Expertise from the Traditional Boat Manufacturing Industry and Electrical Engineers** Our company’s founders have been in the boat building business for over 25 years. Our boat design and manufacturing knowledge are supplemented by engineers with strong skills in electrical engineering and software and controls.
- **Rapid Customer-Focused Product Development.** We are designing our product development process to rapidly react to data collected from our boats, direct interaction with our customers, and feedback from our web and app platform. That information should enable us to introduce new models and features to expand our customer base and brand recognition.
- **Direct To Consumer System.** We are building a vertically integrated and premium direct-to-consumer system while achieving operating efficiencies and capturing sales and service revenues traditional boat manufacturers do not generally receive in the distribution and service model they employ.
- **Capital Efficiency.** We believe our rapid product development process, powertrain technology applicable for future boat models, and our plan to hold lower inventory levels while still meeting customer demand will help reduce the capital required to reach operating efficiencies. This approach is designed to allow us to achieve profitability at relatively low sales volumes and create a viable long-term business.

Our Strategy

We plan to operate in a fundamentally different manner and structure than traditional marine manufacturers and boat dealers by adopting a direct-to-consumer sales and delivery model. We are building a dedicated web and app-based platform for sales, deliveries, and service operations to change the personal boat buying and marine service experience through technological innovation, ease of use, and flexibility. We intend to employ an integrated, digital-first strategy that is convenient and transparent for our customers and efficient and scalable to support our growth. We believe our approach will enable us to operate more cost effectively, provide a better customer experience and incorporate customer feedback more quickly into our product development and manufacturing processes. We believe this strategy will allow us to deliver uncompromised and premium experiences well beyond what is available through the standard dealership model.

Our plans include the following strategies:

- **Successfully Launch the FX1.** We believe the successful launch of our first commercially available electric boat is critical to our ability to capitalize on the marine electric vehicle market opportunity and establish ourselves as leaders in the industry. We plan to complete the initial prototype boat by Q2 2022 and to commence commercial scale production in Q2 2023. We are currently executing a detailed plan to design, component source, engineer, and manufacture the FX1 and obtain the equipment to support its production.
- **Invest in Our Infrastructure.** We plan to invest in our product development and operations infrastructure to enable our growth, product innovation, and customer experience
- **Use a Common Platform to Introduce New Models.** We intend to design the FX1 with an adaptable platform architecture and common electric powertrain to provide us the flexibility to use the FX1 platform to launch subsequent electric boat models cost-efficiently.
- **Focus on Technological Advancements and Cost Improvement.** We intend to constantly look for ways to improve upon and further develop our proprietary electric powertrain system while reducing its manufacturing cost.
- **Build our Company-Owned Sales and Service Network.** Forza X1 is programming and building our expansive and vertically integrated customer-centric web and app platform to connect with customers for an end-to-end experience encompassing everything from buying, financing, delivery, servicing, and training. This customer-centric approach to sales and service will simplify accessing necessary information for potential buyers and current owners in an easily accessible and streamlined online space.
- **Leverage Industry Advancements in Battery Cells.** We intend to leverage the substantial investments made globally by battery cell manufacturers to improve power and capacity.
- **Build and Leverage Strategic Relationships.** We intend to establish and develop strategic relationships with industry leaders to launch our planned electric boats and sell our electric boat powertrain components. We envision significant inroads with boat manufacturers to retrofit various hull configurations, replacing traditional gas outboard motors and existing boat owners who could retrofit their boats with Forza X1's outboard motors, controller, and battery packs.

Summary of Risks Associated with Our Business

- We are a start-up entity and expect to incur significant expenses and continuing losses for the foreseeable future.
- Our limited operating history makes it difficult for us to evaluate our future business prospects.
- Our planned fully electric sport boat has not yet been developed, and even if developed, an interest in it may not develop.
- Our distribution model is different from the predominant current distribution model for boat manufacturers, which subjects us to substantial risk and makes evaluating our business, prospects, financial condition, results of operations, and cash flows difficult.

- We may be unable to adequately control the capital expenditures and costs associated with our business and operations.
- We could experience cost increases or disruptions in supply of raw materials or other components used in our vehicles.
- Our ability to meet our manufacturing workforce needs is crucial to our results of operations and future sales and profitability.
- We have a large fixed cost base that will affect our profitability if our sales decrease.
- Interest rates and energy prices affect product sales.
- All of our outstanding common stock is currently owned by a single stockholder, and it may therefore be able to substantially control our management and affairs after this offering.
- Our business may be materially affected by the COVID-19 Outbreak.
- Our annual and quarterly financial results are subject to significant fluctuations depending on various factors, many of which are beyond our control.
- Our success depends, in part, upon the ability of our customers to access to third-party consumer financing.
- Unfavorable weather conditions may have a material adverse effect on our business, financial condition, and results of operations, especially during the peak boating season.
- A natural disaster, the effects of climate change, or disruptions at our manufacturing facility could adversely affect our business, financial condition and results of operations.
- If we fail to manage our manufacturing levels while still addressing the seasonal retail pattern for our products, our business and margins may suffer.

- Product liability, warranty, personal injury, property damage and recall claims may materially affect our financial condition and damage our reputation
- Our industry is characterized by intense competition, which affects our sales and profits.
- The electronic vehicle (EV) industry and its technology are rapidly evolving and may be subject to unforeseen changes which could adversely affect the demand for our boats or increase our operating costs.
- If we experience delays in the development of our fully electric sport boat, fail to bring the FX1 to market as and when planned or if it fails to gain market acceptance, our bottom line will suffer.
- Our patent applications may not issue as patents, which may have a material adverse effect on our ability to prevent others from commercially exploiting products similar to ours.
- We may need to defend ourselves against patent, copyright or trademark infringement claims, which may be time-consuming and would cause us to incur substantial costs.
- Demand in the powerboat industry is highly volatile.
- General economic conditions, particularly in the U.S., affect our industry, demand for our products and our business, and results of operations.

Implications of Being an Emerging Growth Company and a Smaller Reporting Company

We qualify as an “emerging growth company” as defined in the Jumpstart Our Business Startups Act of 2012, as amended, or the JOBS Act. As an “emerging growth company,” we may take advantage of specified reduced disclosure and other requirements that are otherwise applicable generally to public companies. These provisions include, but are not limited to:

- requiring only two years of audited financial statements in addition to any required unaudited interim financial statements with correspondingly reduced “Management’s discussion and analysis of financial condition and results of operations” in our Securities Act of 1933, as amended, or the Securities Act, filings;
- reduced disclosure about our executive compensation arrangements;
- no non-binding advisory votes on executive compensation or golden parachute arrangements; and
- exemption from compliance with the auditor attestation requirement in the assessment of our internal control over financial reporting pursuant to Section 404(b) of the Sarbanes Oxley Act of 2002, or SOX.

We may take advantage of these exemptions for up to five years or such earlier time that we are no longer an “emerging growth company.” We will continue to remain an “emerging growth company” until the earliest of the following: (i) the last day of the fiscal year following the fifth anniversary of the date of the completion of this offering; (ii) the last day of the fiscal year in which our total annual gross revenue is equal to or more than \$1.07 billion; (iii) the date on which we have issued more than \$1 billion in nonconvertible debt during the previous three years; or (iv) the date on which we are deemed to be a large accelerated filer under the rules of the Securities and Exchange Commission, or the SEC.

We are also a “smaller reporting company” as defined in the Securities Exchange Act of 1934, as amended, or the Exchange Act, and have elected to take advantage of certain of the scaled disclosures available to smaller reporting companies. To the extent that we continue to qualify as a “smaller reporting company” as such term is defined in Rule 12b-2 under the Exchange Act, after we cease to qualify as an emerging growth company, certain of the exemptions available to us as an “emerging growth company” may continue to be available to us as a “smaller reporting company,” including exemption from compliance with the auditor attestation requirements pursuant to SOX and reduced disclosure about our executive compensation arrangements. We will continue to be a “smaller reporting company” until we have \$250 million or more in public float (based on our common stock) measured as of the last business day of our most recently completed second fiscal quarter or, in the event we have no public float (based on our common stock) or a public float (based on our common stock) that is less than \$700 million, annual revenues of \$100 million or more during the most recently completed fiscal year.

We may choose to take advantage of some, but not all, of these exemptions. We have taken advantage of reduced reporting requirements in this prospectus. Accordingly, the information contained herein may be different from the information you receive from other public companies in which you hold stock. In addition, the JOBS Act provides that an emerging growth company may take advantage of an extended transition period for complying with new or revised accounting standards, delaying the adoption of these accounting standards until they would apply to private companies. We have elected to avail ourselves of the extended transition period for complying with new or revised financial accounting standards. As a result of the accounting standards election, we will not be subject to the same implementation timing for new or revised accounting standards as other public companies that are not emerging growth companies which may make comparison of our financials to those of other public companies more difficult.

Corporate Information

Our principal executive office is located at 3101 S. US-1, Ft. Pierce, Florida 34982, and our telephone number is (772) 429-2525. We maintain our corporate website at www.forzax1.com. The reference to our website is an inactive textual reference only. The information that can be accessed through our website is not part of this prospectus. Investors should not rely on any such information in deciding whether to purchase our common stock.

Forza X1, Inc. was initially incorporated as Electra Power Sports, Inc. on October 15, 2021, but we subsequently changed our name to Forza X1, Inc. on October 29, 2021. Our parent company was incorporated in the State of Florida as Twin Vee Catamarans, Inc. on December 1, 2009, and reincorporated in Delaware on April 7, 2021, as Twin Vee PowerCats Co. (“Twin Vee”). Prior to our incorporation in October 2021, we operated as the Electra Power Sports™ Division of Twin Vee. As of the date of this prospectus, we have ten employees.

THE OFFERING

Common stock offered by us	shares (or shares if the underwriters exercise in full their option to purchase additional shares to cover over-allotments, if any)
Common stock to be outstanding after this offering	shares (or shares if the underwriters exercise in full their option to purchase additional shares to cover over-allotments, if any) ⁽¹⁾
Over-allotment option	shares (which may be purchased from us for 45 days from the date of this prospectus to cover over-allotments, if any)
Use of proceeds	<p>We estimate that the net proceeds from our issuance and sale of shares of our common stock in this offering will be approximately \$ million, assuming an initial public offering price of \$ per share, which is the midpoint of the estimated initial public offering price range set forth on the cover page of this prospectus, and after deducting the underwriting discounts and commissions and estimated offering expenses payable by us. If the underwriters exercise their option to purchase additional shares in full to cover over-allotments, if any, we estimate that our net proceeds will be approximately \$ million.</p> <p>We currently anticipate using the net proceeds from this offering, together with our existing resources, as follows: (i) \$ for the design, development, testing, production and marketing of our electric boats; (ii) \$ for the design, development, testing, production and marketing of our electric outboard motors; (iii) \$ for the design, development, testing, manufacturing of our integrated control system; (iv) \$ for the acquisition of property and the development of a manufacturing plant to build, design and manufacture our new line of electric boats; (v) \$ for the development of a vertically integrated direct-to-consumer distribution platform; and (vi) \$ for working capital. See the section titled “Use of Proceeds” for additional information.</p>
Risk Factors	See “Risk Factors” beginning on page 10 and the other information included in this prospectus for a discussion of factors you should carefully consider before investing in our securities.
Proposed Nasdaq Capital Market trading symbol	We have applied to have our common stock listed on the Nasdaq Capital Market under the symbol “FRZA.”

- (1) The number of shares of our common stock to be outstanding after this offering is based on the shares of our common stock outstanding as of December , 2021 and excludes the following:

Unless otherwise indicated, this prospectus reflects and assumes the following:

- no exercise by the underwriters of their option to purchase up to additional shares of our common stock from us to cover over-allotments, if any;
- no exercise of the representative’s warrants to be issued upon consummation of this offering at an exercise price equal to 125% of the initial offering price of the common stock; and
- an assumed initial public offering price of \$ per share, which is the midpoint of the estimate of the price range set forth on the cover page of this prospectus.

8

SUMMARY FINANCIAL DATA

The following table summarizes the relevant financial data for our business and should be read with our financial statements, which are included in this prospectus. We have not had any significant operations to date, so only balance sheet data is presented.

The following tables present our summary balance sheet data and should be read together with our financial statements and accompanying notes and “Management’s Discussion and Analysis of Financial Condition and Results of Operations” appearing elsewhere in this prospectus. The summary balance sheet data for the period of inception (October 15, 2021) through ended December 31, 2021 is derived from our audited annual financial statements, which are included elsewhere in this prospectus.

Balance Sheet Data:	December 31,	
	2021	As Adjusted(1)
Working capital	\$ 1,246,384	
Total assets	\$ 2,232,827	
Total liabilities	\$ 645,378	
Stockholder’s equity	\$ 1,587,449	

- (1) The as adjusted balance sheet data in the table above reflects the sale and issuance by us of shares of our common stock in this offering, based upon the assumed initial public offering price of \$, after deducting the underwriting discounts and commissions and estimated offering expenses payable by us.

9

RISK FACTORS

Investing in our common stock involves a high degree of risk. You should carefully consider the risks described below, as well as the other information in this prospectus, including our financial statements and the related notes and the section titled “Management’s Discussion and Analysis of Financial Condition and Results of Operations” in this prospectus, before deciding whether to invest in our common stock. The occurrence of any of the events or developments described below could harm our business, financial condition, results of operations and growth prospects. In such an event, the market price of our common stock could decline and you may lose all or part of your investment. Additional risks and uncertainties not presently known to us or that we currently deem immaterial also may impair our business operations.

RISKS RELATED TO OUR BUSINESS

We are a start-up entity and expect to incur significant expenses and continuing losses for the foreseeable future.

We are a start-up entity and have had very limited operations to date. To date, we have designed and manufactured only prototypes of our electric sport boat, have not yet commercialized our boats and have not sold any boats. We believe that we will continue to incur operating and net losses in the future while we grow, including following our initial generation of revenues from the sale of our boats which may occur later than we expect or not at all. We do not expect to be profitable for the foreseeable future as we invest in our business, build capacity and ramp up operations, and we cannot assure you that we will ever achieve or be able to maintain profitability in the future. Even if we are able to successfully develop our boats and attract customers, there can be no assurance that we will be financially successful. For example, as we develop our product portfolio, we will need to manage costs effectively to sell those products at our expected margins. Failure to become profitable would materially and adversely affect the value of your investment. If we are ever to achieve profitability, it will be dependent upon the successful development and commercial introduction and acceptance of our electric sport boats and the development of a vertically integrated direct-to-consumer distribution system to market and sell our boats, which may not occur. As such, for the foreseeable future, we will have to fund all our operations and capital expenditures from cash on hand, and potentially, future offerings of securities. However, unanticipated changes may occur that could consume our available capital before we expect, including changes in and progress of our development activities.

Our independent registered public accounting firm has expressed substantial doubt about our ability to continue as a going concern

The report of our independent registered public accounting firm contains a note stating that the accompanying financial statements have been prepared assuming we will continue as a going concern. Since inception (October 15, 2021), we have incurred net operating losses and used cash in operations. For the period from inception (October 15, 2021) through December 31, 2021, we incurred a net loss of \$412,551 and used cash in operations of \$259,107 for the period of inception (October 15, 2021) through December 31, 2021. Losses have principally occurred as a result of the research and development efforts coupled with no operating revenue.

Without raising capital, there is a substantial doubt about our ability to continue as a going concern through December 31, 2022.

Our limited operating history makes it difficult for us to evaluate our future business prospects.

We are a company with an extremely limited operating history and have not generated any revenue from sales of our boats or other products and services to date. As we attempt to transition from research and development activities to production and sales, it is difficult, if not impossible, to forecast our future results, and we have limited insight into trends that may emerge and affect our business. The estimated costs and timelines that we have developed to design and complete the design and engineering of the FX1 sport boat and its outboard electric motor and then reach full scale commercial production are subject to inherent risks and uncertainties involved in the transition from a start-up company focused on research and development activities to the large-scale manufacture and sale of vehicles. There can be no assurance that our estimates related to the costs and timing necessary to complete the design and engineering of the FX1 sport boat and its outboard electric motor, will prove accurate. These are complex processes that may be subject to delays, cost overruns and other unforeseen issues. In addition, we have engaged in limited marketing activities to date, so even if we are able to bring the FX1 or other commercial products to market, on time and on budget, there can be no assurance that customers will embrace our products in significant numbers. Market conditions, many of which are outside of our control and subject to change, including general economic conditions, the availability and terms of third-party consumer financing, the impacts and ongoing uncertainties created by the COVID-19 pandemic, fuel and energy prices, regulatory requirements and incentives, competition and the pace and extent of vehicle electrification generally, will impact demand for the FX1 and our other commercial products, and ultimately our success.

You should consider our business and prospects in light of the risks and significant challenges we face as a new entrant into our industry. If we fail to adequately address any or all of these risks and challenges, our business, prospects, financial condition, results of operations, and cash flows may be materially and adversely affected.

Our planned fully electric sport boat has not yet been developed, and even if developed, an interest in it may not develop.

We have not completed the design and engineering of the FX1 sport boat. There can be no assurance that we will be able to complete development of the FX1 when anticipated, if at all, that we will be able to mass produce the FX1 or that the anticipated features or services to be included in the FX1 will create substantial interest or a market, and therefore our anticipated FX1 product, its sales and growth for our product may not develop as expected, or at all. For example, in May 2021 we experienced a small fire in connection with the sea trial of a prototype of our electric boat which resulted in a six-month delay in our design timetable as we implemented changes to the design for outboard electric motor system as a result of the fire. We cannot guarantee that similar events will not occur in the future, or that we will be able to contain such events without damage or delay. Even if such a market for the FX1 sport boat develops, there can be no assurance that we would be able to maintain that market.

Our operations to date have been primarily limited to finalizing our design and engineering of our electric sport boat as well as organizing and staffing our company in preparation for launching the FX1 electric boat. As such we have not yet demonstrated, and our success is wholly dependent upon, our ability to commercialize our products. The successful commercialization of any products will require us to perform a variety of functions, including:

- completing the design and testing for the FX1 sport boat and our proprietary outboard electric motor
- manufacturing the FX1 sport boats
- developing a vertically integrated direct-to-consumer distribution system
- conducting sales and marketing activities.

We cannot be certain that our business strategy will be successful or that we will successfully address these risks. In the event that we do not successfully address these risks, our business, prospects, financial condition, and results of operations could be materially and adversely affected, and we may not have the resources to continue or expand our business operations.

Our distribution model is different from the predominant current distribution model for boat manufacturers, which subjects us to substantial risk and makes evaluating our business, prospects, financial condition, results of operations, and cash flows difficult.

We plan to sell our boats directly to customers rather than through franchised dealerships, primarily through Forza X1 customer experience and services centers, subject to obtaining applicable dealer licenses and equivalent permits in such jurisdictions, offering a digital customer experience via our online platform. This model of boat distribution is relatively new, different from the predominant current distribution model for boat manufacturers and, with limited exceptions, unproven, which subjects us to substantial risk. We have no experience in selling or leasing boats direct-to-consumer and therefore this model may require significant expenditures and provide for slower expansion than the traditional dealer franchise system. For example, we will not be able to utilize long established relationships developed by our parent company with its dealer network. Moreover, we will be competing with companies with well established distribution channels. Our success will depend in large part on our ability to effectively develop our own sales channels and marketing strategies.

Implementing our direct sales model is subject to numerous significant challenges, including obtaining permits and approvals from government authorities, and we may not be successful in addressing these challenges. If our direct sales model does not develop as expected or develops more slowly than expected, we may be required to modify or abandon our sales model, which could materially and adversely affect our business, prospects, financial condition, results of operations, and cash flows.

Our ability to generate meaningful product revenue will depend on consumer adoption of electric boats.

We are only developing electric boats and, accordingly, our ability to generate meaningful product revenue will highly depend on sustained consumer demand for alternative fuel vehicles in general and electric boats in particular. If the market for electric boats does not develop as we expect or develops more slowly than we expect, or if there is a decrease in consumer demand for electric vehicles, our business, prospects, financial condition and results of operations will be harmed. The market for electric and other alternative fuel vehicles is relatively new, rapidly evolving, characterized by rapidly changing technologies, price competition, additional competitors, evolving government regulation (including government incentives and subsidies) and industry standards, frequent new vehicle announcements and changing consumer demands and behaviors. Any number of changes in the industry could negatively affect consumer demand for electric vehicles in general and our electric boats in particular.

In addition, demand for electric boats may be affected by factors directly impacting boat prices or the cost of purchasing and operating boats such as sales and financing incentives including tax credits, prices of raw materials and parts and components, cost of fuel, availability of consumer credit, and governmental regulations, including tariffs, import regulation and other taxes. Volatility in demand may lead to lower vehicle unit sales, which may result in downward price pressure and adversely affect our business, prospects, financial condition and results of operations. Further, sales of boats in the marine industry tend to be cyclical in many markets, which may expose us to increased volatility, especially as we expand and adjust our operations and retail strategies. Specifically, it is uncertain how such macroeconomic factors will impact us as a new entrant in an industry that has globally been experiencing a recent decline in sales.

Other factors that may influence the adoption of electric boats include:

- perceptions about electric vehicle quality, safety, design, performance and cost;
- perceptions about the limited range over which electric boats may be driven on a single battery charge;
- perceptions about the total cost of ownership of electric boats, including the initial purchase price and operating and maintenance costs, both including and excluding the effect of any government and other subsidies and incentives designed to promote the purchase of electric boats;
- perceptions about the sustainability and environmental impact of electric boats, including with respect to both the sourcing and disposal of materials for electric vehicle batteries and the generation of electricity provided in the electric grid;
- the availability of other alternative fuel boats;
- improvements in the fuel economy of the internal combustion engine;
- the quality and availability of service for electric boats;
- volatility in the cost of oil and gasoline;
- government regulations and economic incentives promoting fuel efficiency and alternate forms of energy;
- access to charging stations and cost to charge an electric vehicle and related infrastructure costs and standardization;
- the availability of tax and other governmental incentives to purchase and operate electric boats or future regulation requiring increased use of nonpolluting boats; and
- macroeconomic factors.

The influence of any of the factors described above or any other factors may cause a general reduction in consumer demand for electric vehicles or our electric boats in particular, either of which would materially and adversely affect our business, results of operations, financial condition and prospects

We may be unable to adequately control the capital expenditures and costs associated with our business and operations.

We will require significant capital to develop and grow our business, including developing our first boat to be manufactured, the FX1, as well as building our brand. We expect to make additional capital expenditures and incur substantial costs as we complete the design and engineering of the FX1 and prepare to commercially launch sales of our boats and grow our business, including research and development expenses, raw material procurement costs, sales and distribution expenses as we build our brand and market our boats and general and administrative expenses as we scale our operations, identify and commit resources to investigate new areas of demand and incur costs as a public company. Our ability to become profitable in the future will not only depend on our ability to complete the design and development of our boats but also to control our capital expenditures and costs. As we expand our product portfolio, we will need to manage costs effectively to sell those products at our expected margins. If we are unable to cost efficiently design, manufacture, market, sell and distribute and service our boats and provide our services, our business, prospects, financial condition, results of operations, and cash flows would be materially and adversely affected.

The capacity of the manufacturing facility that we and our parent company utilize will not be sufficient to support our future growth and business plans.

We currently plan to manufacture our electric boats at a new state of the art carbon neutral factory that we plan to build in Fort Pierce Florida. Until we are able to expand our manufacturing capacity and build the planned manufacturing facility, we will continue to share our parent company's current manufacturing facility, which has a limited capacity and may not be able to satisfy our manufacturing needs. Any facility that we build will require a significant capital investment and is expected to take at least one to two years to build and become fully operational.

We could experience cost increases or disruptions in supply of raw materials or other components used in our boats.

We expect to incur significant costs related to procuring raw materials required to manufacture and assemble our boats. The prices for these raw materials fluctuate depending on factors beyond our control including market conditions and global demand for these materials and could adversely affect our business, prospects, financial condition, results of operations, and cash flows. Further, any delays or disruptions in our supply chain could harm our business. For example, COVID-19, including associated variants, could cause disruptions to and delays in our operations, including shortages and delays in the supply of certain parts, including semiconductors, materials and equipment necessary for the production of our boats, and the internal designs and processes we may adopt in an effort to remedy or mitigate impacts of such disruptions and delays could result in higher costs. In addition, our business also depends on the continued supply of battery cells for our boats. We are exposed to multiple risks relating to availability and pricing of quality battery cells. These risks include:

- the inability or unwillingness of battery cell manufacturers to build or operate battery cell manufacturing plants to supply the numbers of battery cells (including the applicable chemistries) required to support the growth of the electric or plug-in hybrid vehicle industry as demand for such cells increases;

- disruption in the supply of battery cells due to quality issues or recalls by the battery cell manufacturers; and
- an increase in the cost, or decrease in the available supply of raw materials used in battery cells, such as lithium, nickel, and cobalt.

Furthermore, currency fluctuations, tariffs or shortages in petroleum and other economic or political conditions may result in significant increases in freight charges and raw material costs. Substantial increases in the prices for our raw materials or components would increase our operating costs and could reduce our margins. In addition, a growth in popularity of electric vehicles without a significant expansion in battery cell production capacity could result in shortages which would result in increased materials costs to us, and would impact our projected manufacturing and delivery timelines, and adversely affect our business, prospects, financial condition, results of operations, and cash flows.

We depend upon third parties to manufacture and to supply key semiconductor chip components necessary for our boats. We do not have long-term agreements with all of our semiconductor chip manufacturers and suppliers, and if these manufacturers or suppliers become unwilling or unable to provide an adequate supply of semiconductor chips, with respect to which there is a global shortage, we would not be able to find alternative sources in a timely manner and our business would be adversely impacted.

Semiconductor chips are a vital input component to the electrical architecture of our boats, controlling wide aspects of the boats' operations. Many of the key semiconductor chips we intend to use in our boats come from limited or single sources of supply, and therefore a disruption with any one manufacturer or supplier in our supply chain would have an adverse effect on our ability to effectively manufacture and timely deliver our boats. We do not have any long-term supply contracts with any suppliers and purchase chips on a purchase order basis. Due to our reliance on these semiconductor chips, we are subject to the risk of shortages and long lead times in their supply. We are in the process of identifying alternative manufacturers for semiconductor chips. We have in the past experienced, and may in the future experience, semiconductor chip shortages, and the availability and cost of these components would be difficult to predict. For example, our manufacturers may experience temporary or permanent disruptions in their manufacturing operations due to equipment breakdowns, labor strikes or shortages, natural disasters, component or material shortages, cost increases, acquisitions, insolvency, changes in legal or regulatory requirements, or other similar problems.

In particular, increased demand for semiconductor chips in 2020, due in part to the COVID-19 pandemic and increased demand for consumer electronics that use these chips, has resulted in a severe global shortage of chips in 2021. As a result, our ability to source semiconductor chips to be used in our boats has been adversely affected. This shortage may result in increased chip delivery lead times, delays in the production of our boats, and increased costs to source available semiconductor chips. To the extent this semiconductor chip shortage continues, and we are unable to mitigate the effects of this shortage, our ability to deliver sufficient quantities of our boats to fulfill our preorders and to support our growth through sales to new customers would be adversely affected. In addition, we may be required to incur additional costs and expenses in managing ongoing chip shortages, including additional research and development expenses, engineering design and development costs in the event that new suppliers must be onboarded on an expedited basis. Further, ongoing delays in production and shipment of boats due to a continuing shortage of semiconductor chips may harm our reputation and discourage additional preorders and boat sales, and otherwise materially and adversely affect our business and operations.

Our ability to meet our manufacturing workforce needs is crucial to our results of operations and future sales and profitability.

We rely on the existence of an available hourly workforce to manufacture our products. We also rely upon our engineers that are specialist in electric engineering. We cannot assure you that we will be able to attract and retain qualified employees to meet current or future needs at a reasonable cost, or at all. For instance, the demand for engineers has increased over the past several years and we will compete with many of the tech companies and automobile companies. In addition, the demand for skilled employees has increased recently with the low unemployment rates in Florida where we have manufacturing facilities. Also, although none of our employees are currently covered by collective bargaining agreements, we cannot assure you that our employees will not elect to be represented by labor unions in the future. Additionally, competition for qualified employees could require us to pay higher wages to attract a sufficient number of employees. Significant increases in manufacturing workforce costs could materially adversely affect our business, financial condition or results of operations.

We have a large fixed cost base that will affect our profitability if our sales decrease.

The fixed cost levels of operating a powerboat manufacturer can put pressure on profit margins when sales and production decline. Our profitability will depend, in part, on our ability to spread fixed costs over a sufficiently large number of products sold and shipped, and if we make a decision to reduce our rate of production, gross or net margins could be negatively affected. Consequently, decreased demand or the need to reduce production can lower our ability to absorb fixed costs and materially impact our financial condition or results of operations.

All of our outstanding common stock is currently owned by a single stockholder, and it may therefore be able to substantially control our management and affairs after this offering.

Our parent company currently owns 100% of our outstanding common stock and will own beneficially approximately 48% of our outstanding common stock immediately after the consummation of the offering. Our Chief Executive Officer is the Chief Executive Officer of our parent company, Twin Vee and a member of its board of directors in addition to beneficially owning 32.10% of the outstanding common stock of our parent company through ownership of 56.14% of Twin Vee Powercats, Inc., the parent company of Twin Vee Powercats Co. As a result, our Chief Executive Officer does and will have significant influence over our management and affairs and over matters requiring stockholder approval, including the election of directors and approval of significant corporate transactions. Therefore, Twin Vee Powercats Co. and its ultimate parent company, Twin Vee Powercats, Inc., will have substantial influence over any election of our directors and our operations. It should also be noted that for the most part, authorization to modify our Certificate of Incorporation, as amended, requires only majority stockholder consent and approval to modify our amended and restated By-Laws requires authorization of only a majority of the board of directors. This concentration of ownership could also have the effect of delaying or preventing a change in our control. Accordingly, our Chief Executive Officer could cause us to enter into transactions or agreements that we would not otherwise consider.

In addition, this concentration of ownership may delay or prevent a change in our control and might affect the market price of our common stock, even when a change in control may be in the best interest of all stockholders. Furthermore, the interests of this concentration of ownership may not always coincide with our interests or the interests of other stockholders.

Our management overlaps substantially with the management and beneficial owners of our principal stockholder, which may give rise to potential conflicts of interest.

Several of our executive officers and directors are also officers and/or directors of our principal stockholder, Twin Vee Powercats Co., and certain of such executive officers and directors are, in turn, the principal stockholders of Twin Vee Powercats Co. Accordingly, there may be inherent, albeit non-specific, potential conflicts involved in the participation by members of each company's management, audit committee, compensation committee, nominating committee and other applicable board committees which will oversee questions of possible conflicts of interest and compensation, notwithstanding an effort to appoint independent directors that do not have these inherent conflicts. In addition, as a matter of practicality, efficiency and appropriate accounting, the costs of certain service (including salaries of executive officers) are allocated, which creates inter-company obligations.

Our business may be materially affected by the COVID-19 Outbreak.

The outbreak of the novel coronavirus (COVID-19) has and may continue to cause disruptions to our business and operational plans. These disruptions may include disruptions resulting from (i) shortages of employees, (ii) unavailability of contractors and subcontractors, (iii) interruption of, or price fluctuations in, supplies from third parties upon which we rely, (iv) restrictions that governments impose to address the COVID-19 outbreak, and (v) restrictions that we and our contractors and subcontractors impose to ensure the safety of employees and others. Delays in our supply chain could adversely impact our production and, in turn, our revenues. Further, it is presently not possible to predict the extent or durations of these disruptions. These disruptions may have a material adverse effect on our business, financial condition and results of operations. Such adverse effect could be rapid and unexpected. These disruptions may severely affect our ability to carry out our business plan for 2022.

Our annual and quarterly financial results are subject to significant fluctuations depending on various factors, many of which are beyond our control

Our sales and operating results are expected to vary significantly from quarter to quarter and year to year depending on various factors, many of which are beyond our control. These factors include, but are not limited to:

- Seasonal consumer demand for our products;
- Discretionary spending habits;
- Changes in pricing in, or the availability of supply in, the powerboat market;
- Failure to maintain a premium brand image;
- Disruption in the operation of our manufacturing facilities;
- Variations in the timing and volume of our sales;
- The timing of our expenditures in anticipation of future sales;
- Sales promotions by us and our competitors;
- Changes in competitive and economic conditions generally;
- Consumer preferences and competition for consumers' leisure time;
- Impact of unfavorable weather conditions;
- Changes in the cost or availability of our labor; and
- Increased fuel prices.

Due to these and other factors, our results of operations may decline quickly and significantly in response to changes in order patterns or rapid decreases in demand for our products. We anticipate that fluctuations in operating results will continue in the future.

Unfavorable weather conditions may have a material adverse effect on our business, financial condition, and results of operations, especially during the peak boating season.

Adverse weather conditions in any year in any particular geographic region may adversely affect sales in that region, especially during the peak boating season. Sales of our products are expected to be generally stronger just before and during spring and summer, which represent the peak boating months, and favorable weather during these months generally has a positive effect on consumer demand. Conversely, unseasonably cool weather, excessive rainfall, reduced rainfall levels, or drought conditions during these periods may close area boating locations or render boating dangerous or inconvenient, thereby generally reducing consumer demand for our products. Our annual results would be materially and adversely affected if our net sales were to fall below expected seasonal levels during these periods. We may also experience more pronounced seasonal fluctuation in net sales in the future as we expand our businesses. There can be no assurance that weather conditions will not have a material effect on the sales of any of our products.

A natural disaster, the effects of climate change, or other disruptions at our manufacturing facility could adversely affect our business, financial condition, and results of operations.

We currently rely on the continuous operation of our parent company's manufacturing facility in Fort Pierce, Florida for the production of our prototypes and expect such reliance to continue until such time, if ever, that we build a new facility to manufacture our electric boats. Any natural disaster or other serious disruption to our parent's facility or any new facility due to fire, flood, earthquake, or any other unforeseen circumstance would adversely affect our business, financial condition, and results of operations. Changes in climate could adversely affect our operations by limiting or increasing the costs associated with equipment or fuel supplies. In addition, adverse weather conditions, such as increased frequency and/or severity of storms, or floods could impair our ability to operate by damaging our parents or our facilities and equipment or restricting product delivery to customers. The occurrence of any disruption at any such manufacturing facility, even for a short period of time, may have an adverse effect on our productivity and profitability, during and after the period of the disruption. These disruptions may also cause personal injury and loss of life, severe damage to or destruction of property and equipment, and environmental damage. Although we maintain property, casualty, and business interruption insurance of the types and in the amounts that we believe are customary for the industry, we are not fully insured against all potential natural disasters or other disruptions to our manufacturing facility.

If we fail to manage our manufacturing levels while still addressing the seasonal retail pattern for our products, our business and margins may suffer

The seasonality of retail demand anticipated for our products, based upon sales of our parent company's products, will require us to manage our manufacturing to address anticipated retail demand. We will need to manage seasonal changes in consumer demand and inventory. If there is weakness in retail demand, we could be required to reduce our production, resulting in lower rates of absorption of fixed costs in our manufacturing and, therefore, lower margins. As a result, we will need to balance the economies of level production with the seasonal retail sales pattern we experience. Failure to adjust manufacturing levels adequately may have a material adverse effect on our financial condition and results of operations.

We will rely on third-party suppliers to provide components and raw materials essential to the construction of our boats and anticipate such reliance to continue once we commercialize our products.

We expect to depend on third-party suppliers to provide components and raw materials essential to the construction of our boats. While we believe that we will leverage our parent's company's relationships with its current suppliers to provide the materials necessary to meet production demand, we cannot assure you that these relationships will continue or that the quantity or quality of materials available from these suppliers will be sufficient to meet our future needs, irrespective of whether we successfully implement our growth strategy. We expect that our need for raw materials and supplies will increase as we produce boats for sale. Our suppliers must be prepared to ramp up operations and, in many cases, hire additional workers and/or expand capacity in order to fulfill the orders that will be placed by us and other customers. Operational and financial

difficulties that our suppliers may face in the future could adversely affect their ability to supply us with the parts and components we need, which could significantly disrupt our operations.

Termination or interruption of informal supply arrangements could have a material adverse effect on our business or results of operations

Although our parent company has long term relationships with many of its suppliers that are also our suppliers, neither we nor our parent company have any formal agreements with any suppliers for the purchase of parts needed and our purchases currently are made on a purchase order basis. We have no binding commitment from our suppliers to supply any specified quantity of materials needed within any specified time period. In the event that our suppliers receive a large number of orders from other customers, there is a possibility that they will not be able to support our needs. If any of our current suppliers were to be unable to provide needed products to us, there can be no assurance that alternate supply arrangements will be made on satisfactory terms. If we need to enter into supply arrangements on unsatisfactory terms, or if there are any delays to our supply arrangements, it could adversely affect our business and operating results.

Product liability, warranty, personal injury, property damage and recall claims may materially affect our financial condition and damage our reputation.

We are engaged in a business that exposes us to claims for product liability and warranty claims in the event our products actually or allegedly fail to perform as expected or the use of our products results, or is alleged to result, in property damage, personal injury or death. Although we maintain product and general liability insurance of the types and in the amounts that we believe are customary for the industry, we are not fully insured against all such potential claims. Our products involve kinetic energy, produce physical motion and are to be used on the water, factors which increase the likelihood of injury or death. Our products will contain lithium-ion batteries, which have been known to catch fire or vent smoke and flame, and chemicals which are known to be, or could later be proved to be, toxic or carcinogenic. Any judgment or settlement for personal injury or wrongful death claims could be more than our assets and, even if not justified, could prove expensive to contest.

We may experience legal claims in excess of our insurance coverage or claims that are not covered by insurance, either of which could adversely affect our business, financial condition and results of operations. Adverse determination of material product liability and warranty claims made against us could have a material adverse effect on our financial condition and harm our reputation. In addition, if any of our products or components in our products are, or are alleged to be, defective, we may be required to participate in a recall of that product or component if the defect or alleged defect relates to safety. Any such recall and other claims could be costly to us and require substantial management attention.

Our boats will use of lithium-ion battery cells, which, if not appropriately managed and controlled, have been observed to catch fire or vent smoke and flame.

The battery packs within our boats are being designed to use of lithium-ion cells. If not properly managed or subject to environmental stresses, lithium-ion cells can rapidly release the energy they contain by venting smoke and flames in a manner that can ignite nearby materials as well as other lithium-ion cells. While the battery pack is designed to contain any single cell's release of energy without spreading to neighboring cells, a field or testing failure of battery packs in our boats could occur, which could result in bodily injury or death and could subject us to lawsuits, field actions (including product recalls), or redesign efforts, all of which would be time consuming and expensive and could harm our brand image. Also, negative public perceptions regarding the suitability of lithium-ion cells for boating applications, the social and environmental impacts of mineral mining or procurement associated with the constituents of lithium-ion cells, or any future incident involving lithium-ion cells, such as a vehicle or other fire, could materially and adversely affect our reputation and business, prospects, financial condition, results of operations, and cash flows.

Significant product repair and/or replacement due to product warranty claims or product recalls could have a material adverse impact on our results of operations

We expect to provide a hull warranty for structural damage of up to ten years. In addition, we expect to provide a three-year limited fiberglass small parts warranty on all on some small fiberglass parts and components such as consoles. Gelcoat is expected to be covered up to one year. Additionally, fiberglass lids, plastic lids, electrical panels, bilge pumps, aerator pumps or other electrical devices (excluding stereos, depth finders, radar, chart plotters except for installation if installed by us), steering systems, electrical panels, and pumps are covered under a one-year basic limited systems warranty. Some materials, components or parts of the boat that will not covered by our limited product warranties will be separately warranted by their manufacturers or suppliers. These other warranties are expected to include warranties covering engines purchased from suppliers and other components. We also expect to offer to provide repairs for no additional cost as part of our new direct to consumer system.

Our standard warranties will require us to repair or replace defective products during such warranty periods at no cost to the consumer. Although we will employ quality control procedures, sometimes a product is distributed that needs repair or replacement. The repair and replacement costs we could incur in connection with a recall could adversely affect our business. In addition, product recalls could harm our reputation and cause us to lose customers, particularly if recalls cause consumers to question the safety or reliability of our products.

The nature of our business exposes us to workers' compensation claims and other workplace liabilities

Certain materials we use require our employees to handle potentially hazardous or toxic substances. While our employees who handle these and other potentially hazardous or toxic materials receive specialized training and wear protective clothing, there is still a risk that they, or others, may be exposed to these substances. Exposure to these substances could result in significant injury to our employees and damage to our property or the property of others, including natural resource damage. Our personnel are also at risk for other workplace-related injuries, including slips and falls. We may in the future be subject to fines, penalties, and other liabilities in connection with any such injury or damage. Although we currently maintain what we believe to be suitable and adequate insurance in excess of our self-insured amounts, we may be unable to maintain such insurance on acceptable terms or such insurance may not provide adequate protection against potential liabilities.

If we are unable to comply with environmental and other regulatory requirements, our business may be exposed to material liability and/or fines

Our operations are subject to extensive and frequently changing federal, state, local, and foreign laws and regulations, including those concerning product safety, environmental protection, and occupational health and safety. Some of these laws and regulations require us to obtain permits, and limit our ability to discharge hazardous materials into the environment. If we fail to comply with these requirements, we may be subject to civil or criminal enforcement actions that could result in the assessment of fines and penalties, obligations to conduct remedial or corrective actions, or, in extreme circumstances, revocation of our permits or injunctions preventing some or all of our operations. In addition, the components of our boats must meet certain regulatory standards, including stringent air emission standards for boat engines. Failure to meet these standards could result in an inability to sell our boats in key markets, which would adversely affect our business. Moreover, compliance with these regulatory requirements could increase the cost of our products, which in turn, may reduce consumer demand.

While we believe that we are in material compliance with applicable federal, state, local, and foreign regulatory requirements, and hold all licenses and permits required thereunder, we cannot assure you that we will, at all times, be able to continue to comply with applicable regulatory requirements. Compliance with increasingly stringent regulatory and permit requirements may, in the future, cause us to incur substantial capital costs and increase our cost of operations, or may limit our operations, all of which could have a material adverse effect on our business or financial condition.

As with most boat construction businesses, our manufacturing processes involve the use, handling, storage, and contracting for recycling or disposal of hazardous substances and wastes. The failure to manage or dispose of such hazardous substances and wastes properly could expose us to material liability or fines, including liability for personal injury or property damage due to exposure to hazardous substances, damages to natural resources, or for the investigation and remediation of environmental conditions. Under environmental laws, we may be liable for remediation of contamination at sites where our hazardous wastes have been disposed or at our current facility, regardless of whether our facility is owned or leased or whether the environmental conditions were created by us, a prior owner or tenant, or a third-party. While we do not believe that we are presently subject to any such liabilities, we cannot assure you that environmental conditions relating to our prior, existing, or future sites or operations or those of predecessor companies will not have a material adverse effect on our business or financial condition.

Our industry is characterized by intense competition, which affects our sales and profits.

The performance sport boat category and the powerboat industry as a whole are highly competitive for consumers and dealers. We also compete against consumer demand for used boats. Competition affects our ability to succeed in both the markets we currently plan to serve and new markets that we may enter in the future. Competition is based primarily on brand name, price, product selection, and product performance. We will compete with several large manufacturers that may have greater financial, marketing, and other resources than we do and who are represented by dealers in the markets in which we now operate and into which we plan to expand. We also will compete with a variety of small, independent manufacturers. We cannot assure you that we will not face greater competition from existing large or small manufacturers or that we will be able to compete successfully with new competitors. Our failure to compete effectively with our current and future competitors would adversely affect our business, financial condition, and results of operations.

The electronic vehicle (EV) industry and its technology are rapidly evolving and may be subject to unforeseen changes which could adversely affect the demand for our boats or increase our operating costs.

We may be unable to keep up with changes in EV technology or alternatives to electricity as a fuel source and, as a result, our competitiveness may suffer. Developments in alternative technologies, such as advanced diesel, hydrogen, ethanol, fuel cells, or compressed natural gas, or improvements in the fuel economy of the internal combustion engine or the cost of gasoline, may materially and adversely affect our business and prospects in ways we do not currently anticipate. Existing and other battery cell technologies, fuels or sources of energy may emerge as customers' preferred alternative to our boats. Any failure by us to develop new or enhanced technologies or processes, or to react to changes in existing technologies, could materially delay our development and introduction of new and enhanced alternative fuel and EVs, which could result in the loss of competitiveness of our boats, decreased revenue and a loss of market share to competitors. Our research and development efforts may not be sufficient to adapt to changes in alternative fuel and electric vehicle technology. As technologies change, we plan to upgrade or adapt our boats with the latest technology. However, our boats may not compete effectively with alternative systems if we are not able to source and integrate the latest technology into our boats. Additionally, the introduction and integration of new technologies into our boats may increase our costs and capital expenditures required for the production and manufacture of our boats and, if we are unable to cost efficiently implement such technologies or adjust our manufacturing operations, our business, prospects, financial condition, results of operations, and cash flows would be materially and adversely affected.

Our sales and profitability depend, in part, on the successful introduction of new products.

Market acceptance of our products will depend on our technological innovation and our ability to implement technology in our boats. Our sales and profitability may be adversely affected by difficulties or delays in product development, such as an inability to develop viable or innovative new products or to add new features. Our failure to introduce new technologies and product offerings that consumers desire could adversely affect our business, financial condition, and results of operations. If we fail to introduce new features or those we introduce fail to gain market acceptance, our bottom line may suffer.

If we experience delays in the development of our fully electric sport boat, fail to bring the FX1 to market as and when planned or if it fails to gain market acceptance, our bottom line will suffer.

In addition, some of our direct competitors and indirect competitors may have significantly more resources to develop and patent new technologies. It is possible that our competitors will develop and patent equivalent or superior technologies and other products that compete with ours. They may assert these patents against us and we may be required to license these patents on unfavorable terms or cease using the technology covered by these patents, either of which would harm our competitive position and may materially adversely affect our business.

We also cannot be certain that our products or features have not infringed or will not infringe the proprietary rights of others. Any such infringement could cause third parties, including our competitors, to bring claims against us, resulting in significant costs and potential damages.

Our success depends upon the continued strength of our brand, the value of our brand, and sales of our products could be diminished if we, the consumers who use our products, or the sports and activities in which our products are used are associated with negative publicity.

We believe that our brand will be a significant contributor to the success of our business and that maintaining and enhancing our brand is important to expanding our consumer and dealer base. Failure to continue to protect our brand may adversely affect our business, financial condition, and results of operations. We expect that our ability to develop, maintain and strengthen the Forza X1 brand will also depend heavily on the success of our marketing efforts. To further promote our brand, we may be required to change our marketing practices, which could result in substantially increased advertising expenses, including the need to use traditional media such as television, radio and print. Many of our current and potential competitors have greater name recognition, broader customer relationships and substantially greater marketing resources than we do. If we do not develop and maintain strong brands, our business, prospects, financial condition and operating results will be materially and adversely impacted.

Negative publicity, including that resulting from severe injuries or death occurring in the sports and activities in which our products are used, could negatively affect our reputation and result in restrictions, recalls, or bans on the use of our products. If the popularity of the sports and activities for which we design, manufacture, and sell products were to decrease as a result of these risks or any negative publicity, sales of our products could decrease, which could have an adverse effect on our net sales, profitability, and operating results. In addition, if we become exposed to additional claims and litigation relating to the use of our products, our reputation may be adversely affected by such claims, whether or not successful, including by generating potential negative publicity about our products, which could adversely impact our business and financial condition.

Our passion and focus on delivering a high-quality and engaging Forza X1 experience may not maximize short-term financial results, which may yield results that conflict with the market's expectations and could result in our stock price being negatively affected.

We are passionate about enhancing the Forza X1 experience with a focus on driving long-term customer engagement through innovative, technologically advanced boats, which may not necessarily maximize short-term financial results. We frequently make business decisions that may reduce our short-term financial results if we believe that the decisions are consistent with our goals to improve the Forza X1 experience, which we believe will improve our financial results over the long-term. In the near-term, we will focus significant resources on research and development and sales and marketing to deliver the Forza experience to our customers, which could impact our short-term financial results. These decisions may not be consistent with the short-term expectations of our stockholders and may not produce the long-term benefits that we expect, in which case our customer growth, and our business, prospects, financial condition, results of operations, and cash flows could be harmed.

Extended periods of low gasoline or other petroleum-based fuel prices could adversely affect demand for our boats, which would adversely affect our business, prospects, results of operations and financial condition.

A portion of the current and expected demand for electric vehicles results from concerns about volatility in the cost of gasoline and other petroleum-based fuel, the dependency of the United States on oil from unstable or hostile countries, government regulations and economic incentives promoting fuel efficiency and alternative forms of energy, as well as concerns about climate change resulting in part from the burning of fossil fuels. If the cost of gasoline and other petroleum-based fuel decreases significantly, the outlook for the long-term supply of oil to the United States improves, the government eliminates or modifies its regulations or economic incentives related to fuel efficiency and alternative forms of energy or there is a change in the perception that the burning of fossil fuels negatively impacts the environment, the demand for electric vehicles, including our boats, could be reduced, and our business and revenue may be harmed.

20

Gasoline and other petroleum-based fuel prices have historically been extremely volatile, particularly during the ongoing COVID-19 pandemic, and it is difficult to ascertain whether such volatility will continue to persist. Lower gasoline or other petroleum-based fuel prices over extended periods of time may lower the perception in government and the private sector that cheaper, more readily available energy alternatives should be developed and produced. If gasoline or other petroleum-based fuel prices remain at deflated levels for extended periods of time, the demand for electric vehicles, including our boats, may decrease, which would have an adverse effect on our business, prospects, financial condition and results of operations.

We will rely on complex machinery for our operations, and production involves a significant degree of risk and uncertainty in terms of operational performance, safety, security, and costs.

We expect to rely heavily on complex machinery for our operations and our production will involve a significant degree of uncertainty and risk in terms of operational performance, safety, security, and costs. Our parent company's manufacturing plant consists of large-scale machinery combining many components. The manufacturing plant components are likely to suffer unexpected malfunctions from time to time and will depend on repairs and spare parts to resume operations, which may not be available when needed. Unexpected malfunctions of the manufacturing plant components may significantly affect operational efficiency. Operational performance and costs can be difficult to predict and are often influenced by factors outside of our control, such as, but not limited to, scarcity of natural resources, environmental hazards and remediation, costs associated with decommissioning of machines, labor disputes and strikes, difficulty or delays in obtaining governmental permits, damages or defects in electronic systems, industrial accidents, pandemics, fire, seismic activity, and natural disasters. Should operational risks materialize, it may result in the personal injury to or death of workers, the loss of production equipment, damage to manufacturing facilities, products, supplies, tools and materials, monetary losses, delays and unanticipated fluctuations in production, environmental damage, administrative fines, increased insurance costs, and potential legal liabilities, all which could have a material adverse effect on our business, prospects, financial condition, results of operations, and cash flows. Although we generally carry insurance to cover such operational risks, we cannot be certain that our insurance coverage will be sufficient to cover potential costs and liabilities arising therefrom. A loss that is uninsured or exceeds policy limits may require us to pay substantial amounts, which could adversely affect our business, prospects, financial condition, results of operations, and cash flows.

If our boats fail to perform as expected, our ability to develop, market and sell or lease our products could be harmed.

Once commercialization commences, our boats may contain defects in design and manufacture that may cause them not to perform as expected or that may require repairs, recalls, and design changes, any of which would require significant financial and other resources to successfully navigate and resolve. Our boats will use a substantial amount of software code to operate, and software products are inherently complex and may contain defects and errors when first introduced. If our boats contain defects in design and manufacture that cause them not to perform as expected or that require repair, or certain features of our boats take longer than expected to become available, are legally restricted or become subject to additional regulation, our ability to develop, market and sell our products and services could be harmed. Although we will attempt to remedy any issues we observe in our products as effectively and rapidly as possible, such efforts could significantly distract management's attention from other important business objectives, may not be timely, may hamper production or may not be to the satisfaction of our customers. Further, our limited operating history and limited field data reduce our ability to evaluate and predict the long-term quality, reliability, durability and performance characteristics of our battery packs, powertrains and boats. There can be no assurance that we will be able to detect and fix any defects in our products prior to their sale or lease to customers.

Any defects, delays or legal restrictions on boat features, or other failure of our boats to perform as expected, could harm our reputation and result in delivery delays, product recalls, product liability claims, breach of warranty claims and significant warranty and other expenses, and could have a material adverse impact on our business, results of operations, prospects and financial condition. As a new entrant to the industry attempting to build customer relationships and earn trust, these effects could be significantly detrimental to us. Additionally, problems and defects experienced by other electric consumer vehicles could by association have a negative impact on perception and customer demand for our boats.

21

In addition, even if our boats function as designed, we expect that the battery efficiency, and hence the range, of our electric boats, like other electric vehicles that use current battery technology, will decline over time. Other factors, such as usage, time and stress patterns, may also impact the battery's ability to hold a charge, or could require us to limit boat battery charging capacity, including via over-the-air or other software updates, for safety reasons or to protect battery capacity, which could further decrease our boats' range between charges. Such decreases in or limitations of battery capacity and therefore range, whether imposed by deterioration, software limitations or otherwise, could also lead to consumer complaints or warranty claims, including claims that prior knowledge of such decreases or limitations would have affected consumers' purchasing decisions. Further, there can be no assurance that we will be able to improve the performance of our battery packs, or increase our boats range, in the future. Any such battery deterioration or capacity limitations and related decreases in range may negatively influence potential customers' willingness to purchase our boats and negatively impact our brand and reputation, which could adversely affect our business, prospects, results of operations and financial condition.

Our boats will rely on software and hardware that is highly technical, and if these systems contain errors, bugs, vulnerabilities, or design defects, or if we are unsuccessful in addressing or mitigating technical limitations in our systems, our business could be adversely affected.

Our boats are expected to rely on software and hardware that is highly technical and complex and may require modification and updates over the life of the boats. In addition, our boats will depend on the ability of such software and hardware to store, retrieve, process and manage large amounts of data. Our software and hardware may contain errors, bugs, vulnerabilities or design defects, and our systems are subject to certain technical limitations that may compromise our ability to meet our objectives. Some errors, bugs, vulnerabilities, or design defects inherently may be difficult to detect and may only be discovered after the code has been released for external or internal use. Although we will attempt to remedy any issues we observe in our boats effectively and rapidly, such efforts may not be timely, may hamper production or may not be to the satisfaction of our customers.

Additionally, if we deploy updates to the software (whether to address issues, deliver new features or make desired modifications) and our over-the-air update procedures fail to properly update the software or otherwise have unintended consequences to the software, the software within our customers' boats will be subject to vulnerabilities or unintended consequences resulting from such failure of the over-the-air update until properly addressed.

If we are unable to prevent or effectively remedy errors, bugs, vulnerabilities or defects in our software and hardware, or fail to deploy updates to our software properly, we

would suffer damage to our reputation, loss of customers, loss of revenue or liability for damages, any of which could adversely affect our business, prospects, financial condition, results of operations, and cash flows.

We have no experience servicing our boats. If we are unable to adequately service our boats, our business, prospects, financial condition and results of operations may be materially and adversely affected.

Because we have not begun commercial production of the FX1, we have no experience servicing or repairing our electric boats. Servicing electric vehicles is different than servicing vehicles with internal combustion engines and requires specialized skills, including high voltage training and servicing techniques. In addition, we plan to partner with certain third parties to perform some of the service on our vehicles, and there can be no assurance that we will be able to enter into acceptable arrangements with any such third-party providers. Further, although such servicing partners may have experience in servicing other electric vehicles, they will initially have no experience in servicing our boats. There can be no assurance that our service arrangements will adequately address the service requirements of our customers to their satisfaction, or that we and our servicing partners will have sufficient resources, experience or inventory to meet these service requirements in a timely manner as the volume of boats we deliver increases. This risk is enhanced by our limited operating history and our limited data regarding our boats' real-world reliability and service requirements. In addition, if we are unable to roll out and establish a widespread service network that provides satisfactory customer service, our customer loyalty, brand and reputation could be adversely affected, which in turn could materially and adversely affect our sales, results of operations, prospects and financial condition.

Our customers will also depend on our customer support team to resolve technical and operational issues relating to the integrated software underlying our boats, a large portion of which we have developed in-house. As we grow, additional pressure may be placed on our customer support team or partners, and we may be unable to respond quickly enough to accommodate short-term increases in customer demand for technical support. We also may be unable to modify the future scope and delivery of our technical support to compete with changes in the technical support provided by our competitors. Increased customer demand for support, without corresponding revenue, could increase costs and negatively affect our results of operations. If we are unable to successfully address the service requirements of our customers, or if we establish a market perception that we do not maintain high-quality support, our brand and reputation could be adversely affected, and we may be subject to claims from our customers, which could result in loss of revenue or damages, and our business, results of operations, prospects and financial condition could be materially and adversely affected.

We may not be able to execute our manufacturing strategy successfully, which could cause the profitability of our products to suffer.

Our manufacturing strategy is designed to improve product quality and increase productivity, while reducing costs and increasing flexibility to respond to ongoing changes in the marketplace. To implement this strategy, we must be successful in our continuous improvement efforts, which depend on the involvement of management, production employees, and suppliers. Any inability to achieve these objectives could adversely impact the profitability of our products and our ability to deliver desirable products to our consumers.

We may need to raise additional capital that may be required to grow our business, and we may not be able to raise capital on terms acceptable to us or at all.

Operating our business and maintaining our growth efforts will require significant cash outlays and advance capital expenditures and commitments. Our current plans also involve constructing a 100,000 square foot state-of-the-art manufacturing facility dedicated to developing and manufacturing our FX series electric boats, the cost of which is uncertain. Although the proceeds of this offering should be sufficient to fund our operations, if cash on hand and cash generated from operations and from this offering are not sufficient to meet our cash requirements, we will need to seek additional capital, potentially through debt or equity financings, to fund our growth. We cannot assure you that we will be able to raise needed cash on terms acceptable to us or at all. Financings may be on terms that are dilutive or potentially dilutive to our stockholders, and the prices at which new investors would be willing to purchase our securities may be lower than the price per share of our common stock in this offering. The holders of new securities may also have rights, preferences or privileges which are senior to those of existing holders of common stock. If new sources of financing are required, but are insufficient or unavailable, we will be required to modify our growth and operating plans based on available funding, if any, which would harm our ability to grow our business.

If we fail to manage future growth effectively, we may not be able to market or sell our products successfully.

Any failure to manage our growth effectively could materially and adversely affect our business, prospects, operating results and financial condition. We plan to expand our operations in the near future. Our future operating results depend to a large extent on our ability to manage this expansion and growth successfully. Risks that we face in undertaking this expansion include:

- expanding our management team;
- hiring and training new personnel;
- forecasting production and revenue;
- expanding our marketing efforts;
- controlling expenses and investments in anticipation of expanded operations;
- establishing or expanding design, manufacturing, sales and service facilities;
- implementing and enhancing administrative infrastructure, systems and processes; and
- expanding into new markets and establishing sales, service and manufacturing operations in such markets.

We intend to continue to hire a number of additional personnel, including design and manufacturing personnel and service technicians for our electric boats and powertrains. Competition for individuals with experience designing, manufacturing and servicing electric boats is intense, and we may not be able to attract, assimilate, train or retain additional highly qualified personnel in the future. The failure to attract, integrate, train, motivate and retain these additional employees could seriously harm our business and prospects.

We depend upon our executive officers and we may not be able to retain them and their knowledge of our business and technical expertise would be difficult to replace

Our future success will depend in significant part upon the continued service of our executive officers. We cannot assure you that we will be able to continue to attract or retain such persons. We do not have an insurance policy on the life of our Chief Executive Officer, and we do not have "key person" life insurance policies for any of our other officers or advisors. The loss of the technical knowledge and management and industry expertise of any of our key personnel could result in delays in product development, loss of customers and sales and diversion of management resources, which could adversely affect our operating results.

We may attempt to grow our business through acquisitions or strategic alliances and new partnerships, which we may not be successful in completing or integrating

We may in the future enter into acquisitions and strategic alliances that will enable us to acquire complementary skills and capabilities, offer new products, expand our consumer base, enter new product categories or geographic markets, and obtain other competitive advantages. We cannot assure you, however, that we will identify acquisition candidates or strategic partners that are suitable to our business, obtain financing on satisfactory terms, complete acquisitions or strategic alliances, or successfully integrate acquired operations into our existing operations. Once integrated, acquired operations may not achieve anticipated levels of sales or profitability, or otherwise perform as expected. Acquisitions also involve special risks, including risks associated with unanticipated challenges, liabilities and contingencies, and diversion of management attention and resources from our existing operations. Similarly, our partnership with leading franchises from other industries to market our products or with third-party technology providers to introduce new technology to the market may not achieve anticipated levels of consumer enthusiasm and acceptance, or achieve anticipated levels of sales or profitability, or otherwise perform as expected.

We rely on network and information systems and other technologies for our business activities and certain events, such as computer hackings, viruses or other destructive or disruptive software or activities may disrupt our operations, which could have a material adverse effect on our business, financial condition and results of operations.

Network and information systems and other technologies are important to our business activities and operations. Network and information systems-related events, such as computer hackings, cyber threats, security breaches, viruses, or other destructive or disruptive software, process breakdowns or malicious or other activities could result in a disruption of our services and operations or improper disclosure of personal data or confidential information, which could damage our reputation and require us to expend resources to remedy any such breaches. Moreover, the amount and scope of insurance we maintain against losses resulting from any such events or security breaches may not be sufficient to cover our losses or otherwise adequately compensate us for any disruptions to our businesses that may result, and the occurrence of any such events or security breaches could have a material adverse effect on our business and results of operations. The risk of these systems-related events and security breaches occurring has intensified, in part because we maintain certain information necessary to conduct our businesses in digital form stored on cloud servers. While we intend to develop and maintain systems seeking to prevent systems-related events and security breaches from occurring, the development and maintenance of these systems is costly and requires ongoing monitoring and updating as technologies change and efforts to overcome security measures become more sophisticated. Despite these efforts, there can be no assurance that disruptions and security breaches will not occur in the future. Moreover, we may provide certain confidential, proprietary and personal information to third parties in connection with our businesses, and while we obtain assurances that these third parties will protect this information, there is a risk that this information may be compromised.

24

Likewise, data privacy breaches by employees or others with permitted access to our systems may pose a risk that sensitive data may be exposed to unauthorized persons or to the public. While we have invested in protection of data and information technology, there can be no assurance that our efforts will prevent breakdowns or breaches in our systems that could adversely affect our business. The occurrence of any of such network or information systems-related events or security breaches could have a material adverse effect on our business, financial condition and results of operations.

Uninsured losses could result in payment of substantial damages, which would decrease our cash reserves and could harm our cash flow and financial condition.

In the ordinary course of business, we may be subject to losses resulting from product liability, accidents, acts of God and other claims against us, for which we may have no insurance coverage. While we currently carry commercial general liability, commercial boat liability, excess liability, product liability, cybersecurity, crime, special crime, drone, cargo stock throughput, builder's risk, owner controlled insurance program, property, owners protective, workers' compensation, employment practices, employed lawyers, production, fiduciary liability and directors' and officers' insurance policies, we may not maintain as much insurance coverage as other original equipment manufacturers do, and in some cases, we may not maintain any at all. Additionally, the policies that we have may include significant deductibles, and we cannot be certain that our insurance coverage will be sufficient to cover all or any future claims against us. A loss that is uninsured or exceeds policy limits may require us to pay substantial amounts, which could adversely affect our financial condition and results of operations. Further, insurance coverage may not continue to be available to us or, if available, may be at a significantly higher cost, especially if insurance providers perceive any increase in our risk profile in the future.

Intellectual Property Risks

Our patent applications may not issue as patents, which may have a material adverse effect on our ability to prevent others from commercially exploiting products similar to ours.

We cannot be certain that we are the first inventor of the subject matter to which we have filed a particular patent application, or that we are the first party to file such a patent application. If another party has filed a patent application for the same subject matter as we have, we may not be entitled to the protection sought by the patent application. Further, the scope of protection of issued patent claims is often difficult to determine. As a result, we cannot be certain that the patent applications that we file will issue, or that our issued patents will afford protection against competitors with similar technology. In addition, our competitors may design around our issued patents, which may adversely affect our business, prospects, financial condition, results of operations, and cash flows.

We may not be able to prevent others from unauthorized use of our intellectual property, which could harm our business and competitive position.

We may not be able to prevent others from unauthorized use of our intellectual property, which could harm our business and competitive position. We rely on a combination of patent, trade secret (including those in our know-how), and other intellectual property laws, as well as employee and third-party nondisclosure agreements, intellectual property licenses, and other contractual rights to establish and protect our rights in our technology and intellectual property. Our patent or trademark applications may not be granted, any patents or trademark registrations that may be issued to us may not sufficiently protect our intellectual property and any of our issued patents, trademark registrations or other intellectual property rights may be challenged by third parties. Any of these scenarios may result in limitations in the scope of our intellectual property or restrictions on our use of our intellectual property or may adversely affect the conduct of our business. Despite our efforts to protect our intellectual property rights, third parties may attempt to copy or otherwise obtain and use our intellectual property or seek court declarations that they do not infringe upon our intellectual property rights. Monitoring unauthorized use of our intellectual property is difficult and costly, and the steps we have taken or will take to prevent misappropriation may not be successful. From time to time, we may have to resort to litigation to enforce our intellectual property rights, which could result in substantial costs and diversion of our resources.

25

Patent, trademark, and trade secret laws vary significantly throughout the world. A number of foreign countries do not protect intellectual property rights to the same extent as do the laws of the United States. Therefore, our intellectual property rights may not be as strong or as easily enforced outside of the United States. Failure to adequately protect our intellectual property rights could result in our competitors offering similar products, potentially resulting in the loss of some of our competitive advantage and a decrease in our revenue which would adversely affect our business, prospects, financial condition, results of operations, and cash flows.

If our patents expire or are not maintained, our patent applications are not granted or our patent rights are contested, circumvented, invalidated or limited in scope, we may not be able to prevent others from selling, developing or exploiting competing technologies or products, which could have a material adverse effect on our business, prospects, financial condition, results of operations, and cash flows.

We cannot assure you that our pending applications will issue as patents. Even if our patent applications issue into patents, these patents may be contested, circumvented or invalidated in the future. In addition, the rights granted under any issued patents may not provide us with adequate protection or competitive advantages. The claims under any patents that issue from our patent applications may not be broad enough to prevent others from developing technologies that are similar or that achieve results similar to ours. The intellectual property rights of others could also bar us from licensing and exploiting any patents that issue from our pending applications. Numerous patents and pending patent applications owned by others exist in the fields in which we have developed and are developing our technology. Many of these existing patents and patent applications might have priority over our patent applications and could subject our patents to invalidation or our patent applications to rejection. Finally, in addition to patents and patent applications that were filed before our patents and patent applications, any of our existing or future patents may also be challenged by others on the basis that they are invalid or unenforceable.

We may in the future become, subject to claims that we or our employees have wrongfully used or disclosed alleged trade secrets of our employees' former employers.

Many of our employees were previously employed by other companies with similar or related technology, products or services. We are, and may in the future become, subject to claims that we or these employees have inadvertently or otherwise used or disclosed trade secrets or other proprietary information of former employers. Litigation may be necessary to defend against these claims. If we fail in defending such claims, we may be forced to pay monetary damages or be enjoined from using certain technology, products, services or knowledge. Even if we are successful in defending against these claims, litigation could result in substantial costs and demand on management resources.

Our use of open source software in our applications could subject our proprietary software to general release, adversely affect our ability to sell our services and subject us to possible litigation, claims or proceedings.

We plan to use open source software in connection with the development and deployment of our products and services. Companies that use open source software in connection with their products have, from time to time, faced claims challenging the use of open source software and/or compliance with open source license terms. As a result, we could be subject to suits by parties claiming ownership of what we believe to be open source software or claiming noncompliance with open source licensing terms. Some open source software licenses may require users who distribute proprietary software containing or linked to open source software to publicly disclose all or part of the source code to such proprietary software and/or make available any derivative works of the open source code under the same open source license, which could include proprietary source code. In such cases, the open source software license may also restrict us from charging fees to licensees for their use of our software. While we will monitor the use of open source software and try to ensure that open source software is not used in a manner that would subject our proprietary source code to these requirements and restrictions, such use could inadvertently occur, in part because open source license terms are often ambiguous and have generally not been interpreted by U.S. or foreign courts.

Further, in addition to risks related to license requirements, use of certain open source software carries greater technical and legal risks than does the use of third-party commercial software. For example, open source software is generally provided as-is without any support or warranties or other contractual protections regarding infringement or the quality of the code, including the existence of security vulnerabilities. To the extent that our platform depends upon the successful operation of open source software, any undetected errors or defects in open source software that we use could prevent the deployment or impair the functionality of our systems and injure our reputation. In addition, the public availability of such software may make it easier for attackers to target and compromise our platform through cyber-attacks. Any of the foregoing risks could materially and adversely affect our business, prospects, financial condition, results of operations, and cash flows.

26

A significant portion of our intellectual property is not protected through patents or formal copyright registration. As a result, we do not have the full benefit of patent or copyright laws to prevent others from replicating our products, product candidates and brands.

We have not protected certain of our intellectual property rights through patents or formal copyright registration, and we do not currently have any issued patents and only have three design and four utility patent applications that we filed for, among other things, our propulsion system being developed and boat design. There can be no assurance that any patent will issue or if issued that the patent will protect our intellectual property. As a result, we may not be able to protect our intellectual property and trade secrets or prevent others from independently developing substantially equivalent proprietary information and techniques or from otherwise gaining access to our intellectual property or trade secrets. In such an instance, our competitors could produce products that are nearly identical to ours resulting in us selling less products or generating less revenue from our sales.

Confidentiality agreements with employees and others may not adequately prevent disclosure of trade secrets and other proprietary information.

We rely on trade secrets, know-how and technology, which are not protected by patents, to protect the intellectual property behind our electric powertrain and for the construction of our boats. We have recently begun to use confidentiality agreements with our collaborators, employees, consultants, outside collaborators and other advisors to protect our proprietary technology and processes. We intend to use such agreements in the future, but these agreements may not effectively prevent disclosure of confidential information and may not provide an adequate remedy in the event of unauthorized disclosure of confidential information. In addition, others may independently discover trade secrets and proprietary information, and in such cases we could not assert any trade secret rights against such party. Costly and time-consuming litigation could be necessary to enforce and determine the scope of our proprietary rights, and failure to obtain or maintain trade secret protection could adversely affect our competitive business position.

We may need to defend ourselves against patent, copyright or trademark infringement claims, which may be time-consuming and would cause us to incur substantial costs.

The status of the protection of our intellectual property is unsettled as we do not have any issued patents, registered trademarks or registered copyrights and other than three design and four utility patent applications, we have not applied for the same. Companies, organizations or individuals, including our competitors, may hold or obtain patents, trademarks or other proprietary rights that would prevent, limit or interfere with our ability to make, use, develop, sell or market our powerboats and electric powertrains or use third-party components, which could make it more difficult for us to operate our business. In the future, we may receive communications from third parties that allege our products or components thereof are covered by their patents or trademarks or other intellectual property rights, we have not received any communication of this kind through February 3, 2022. Companies holding patents or other intellectual property rights may bring suits alleging infringement of such rights or otherwise assert their rights. If we are determined to have infringed upon a third party's intellectual property rights, we may be required to do one or more of the following:

- cease making, using, selling or offering to sell processes, goods or services that incorporate or use the third-party intellectual property;
- pay substantial damages;
- seek a license from the holder of the infringed intellectual property right, which license may not be available on reasonable terms or at all;
- redesign our boats or other goods or services to avoid infringing the third-party intellectual property;
- establish and maintain alternative branding for our products and services; or
- find-third providers of any part or service that is the subject of the intellectual property claim.

27

In the event of a successful claim of infringement against us and our failure or inability to obtain a license to the infringed technology or other intellectual property right, our business, prospects, operating results and financial condition could be materially adversely affected. In addition, any litigation or claims, whether or not valid, could result in substantial costs, negative publicity and diversion of resources and management attention.

Risks Related to Our Industry

Demand in the powerboat industry is highly volatile.

Volatility of demand in the powerboat industry, especially for recreational powerboats and electric powerboats, may materially and adversely affect our business, prospects, operating results and financial condition. The markets in which we will be competing have been subject to considerable volatility in demand in recent periods. Demand for recreational powerboats depends to a large extent on general, economic and social conditions in a given market. Historically, sales of recreational powerboats decrease during economic downturns. We have fewer financial resources than more established powerboat manufacturers to withstand adverse changes in the market and disruptions in demand.

General economic conditions, particularly in the U.S., affect our industry, demand for our products and our business, and results of operations

Demand for premium boat brands has been significantly influenced by weak economic conditions, low consumer confidence, high unemployment, and increased market volatility worldwide, especially in the U.S. In times of economic uncertainty and contraction, consumers tend to have less discretionary income and tend to defer or avoid expenditures for discretionary items, such as our products. Sales of our products are highly sensitive to personal discretionary spending levels. Our business is cyclical in nature and its success is impacted by economic conditions, the overall level of consumer confidence and discretionary income levels. Any substantial deterioration in general economic conditions that diminishes consumer confidence or discretionary income may reduce our sales and materially adversely affect our business, financial condition and results of operations. We cannot predict the duration or strength of an economic recovery, either in the U.S. or in the specific markets where we sell our products. Corporate restructurings, layoffs, declines in the value of investments and residential real estate, higher gas prices, higher interest rates, and increases in federal and state taxation may each materially adversely affect our business, financial condition, and results of operations.

Consumers often finance purchases of our products. Although consumer credit markets have improved, consumer credit market conditions continue to influence demand, especially for boats, and may continue to do so. There continue to be fewer lenders, tighter underwriting and loan approval criteria, and greater down payment requirements than in the past. If credit conditions worsen, and adversely affect the ability of consumers to finance potential purchases at acceptable terms and interest rates, it could result in a decrease in the sales of our products.

Global economic conditions could materially adversely impact demand for our products and services.

Our operations and performance depend significantly on economic conditions. Global financial conditions continue to be subject to volatility arising from international geopolitical developments and global economic phenomenon, as well as general financial market turbulence, including a significant recent market reaction to the novel coronavirus (COVID-19), resulting in a significant reduction in many major market indices. Uncertainty about global economic conditions could result in material adverse effects on our business, results of operations or financial condition. Access to public financing and credit can be negatively affected by the effect of these events on U.S. and global credit markets. The health of the global financing and credit markets may affect our ability to obtain equity or debt financing in the future and the terms at which financing or credit is available to us. These instances of volatility and market turmoil could adversely affect our operations and the trading price of our common shares resulting in:

- customers postponing purchases of our products and services in response to tighter credit, unemployment, negative financial news and/or declines in income or asset values and other macroeconomic factors, which could have a material negative effect on demand for our products and services; and
- third-party suppliers being unable to produce parts and components for our products in the same quantity or on the same timeline or being unable to deliver such parts and components as quickly as before or subject to price fluctuations, which could have a material adverse effect on our production or the cost of such production.

Our sales may be adversely impacted by increased consumer preference for other leisure activities or used boats or the supply of new boats by competitors in excess of demand.

Our boats are not necessities and in times of economic hardship, consumers may cease purchasing non-essential items. Demand for our boats may be adversely affected by competition from other activities that occupy consumers' leisure time and by changes in consumer life style, usage pattern or taste. Similarly, an overall decrease in consumer leisure time may reduce consumers' willingness to purchase and enjoy our boats.

During the economic downturn that commenced in 2008, for example, there was a shift in consumer demand toward purchasing more used boats, primarily because prices for used boats are typically lower than retail prices for new boats. If this were to occur again, it could have the effect of reducing demand among retail purchasers for our new boats. Also, while we have balanced production volumes for our boats to meet demand, our competitors could choose to reduce the price of their products, which could have the effect of reducing demand for our new boats. Reduced demand for new boats could lead to reduced sales by us, which could adversely affect our business, results of operations, and financial condition.

Risks Relating to this Offering and Ownership of our Common Stock

Terms of subsequent financings may adversely impact your investment.

We may have to engage in common equity, debt, or preferred stock financing in the future. Your rights and the value of your investment in our securities could be reduced. Interest on debt securities could increase costs and negatively impacts operating results. Preferred stock could be issued in series from time to time with such designation, rights, preferences, and limitations as needed to raise capital. The terms of preferred stock could be more advantageous to those investors than to the holders of common shares. In addition, if we need to raise more equity capital from the sale of common shares, institutional or other investors may negotiate terms at least as, and possibly more, favorable than the terms of your investment. Common shares which we sell could be sold into any market which develops, which could adversely affect the market price.

If securities analysts do not publish research or reports about our company, or if they issue unfavorable commentary about us or our industry or downgrade our common stock, the price of our common stock could decline.

The trading market for our common stock will depend in part on the research and reports that third-party securities analysts publish about our company and our industry. We may be unable or slow to attract research coverage and if one or more analysts cease coverage of our company, we could lose visibility in the market. In addition, one or more of these analysts could downgrade our common stock or issue other negative commentary about our company or our industry. As a result of one or more of these factors, the trading price of our common stock could decline.

The obligations associated with being a public company will require significant resources and management attention, which may divert from our business operations.

As a result of this offering, we will become subject to the reporting requirements of the Exchange Act and the Sarbanes-Oxley Act. The Exchange Act requires that we file

annual, quarterly, and current reports with respect to our business and financial condition. The Sarbanes-Oxley Act requires, among other things, that we establish and maintain effective internal controls and procedures for financial reporting. As a result, we will incur significant legal, accounting, and other expenses that we did not previously incur.

We do not yet have adequate internal controls, and we cannot provide assurances that these weaknesses will be effectively remediated or that additional material weaknesses will not occur in the future.

As a public company, we will be subject to the reporting requirements of the Exchange Act, and the Sarbanes-Oxley Act. We expect that the requirements of these rules and regulations will continue to increase our legal, accounting and financial compliance costs, make some activities more difficult, time consuming and costly, and place significant strain on our personnel, systems and resources.

The Sarbanes-Oxley Act requires, among other things, that we maintain effective disclosure controls and procedures, and internal control over financial reporting.

We do not yet have effective disclosure controls and procedures, or internal controls over all aspects of our financial reporting. We are continuing to develop and refine our disclosure controls and other procedures that are designed to ensure that information required to be disclosed by us in the reports that we will file with the SEC is recorded, processed, summarized and reported within the time periods specified in SEC rules and in accordance with GAAP. Our management is responsible for establishing and maintaining adequate internal control over our financial reporting, as defined in Rule 13a-15(f) under the Exchange Act. We will be required to expend time and resources to further improve our internal controls over financial reporting, including by expanding our staff. However, we cannot assure you that our internal control over financial reporting, as modified, will enable us to identify or avoid material weaknesses in the future.

We will be required to expend time and resources to further improve our internal controls over financial reporting, including by expanding our staff. However, we cannot assure you that our internal control over financial reporting, as modified, will enable us to identify or avoid material weaknesses in the future.

We have not yet retained sufficient staff or engaged sufficient outside consultants with appropriate experience in GAAP presentation, especially of complex instruments, to devise and implement effective disclosure controls and procedures, or internal controls. We will be required to expend time and resources hiring and engaging additional staff and outside consultants with the appropriate experience to remedy these weaknesses. We cannot assure you that management will be successful in locating and retaining appropriate candidates; that newly engaged staff or outside consultants will be successful in remedying material weaknesses thus far identified or identifying material weaknesses in the future; or that appropriate candidates will be located and retained prior to these deficiencies resulting in material and adverse effects on our business.

Our current controls and any new controls that we develop may become inadequate because of changes in conditions in our business, including increased complexity resulting from our international expansion. Further, weaknesses in our disclosure controls or our internal control over financial reporting may be discovered in the future. Any failure to develop or maintain effective controls, or any difficulties encountered in their implementation or improvement, could harm our operating results or cause us to fail to meet our reporting obligations and may result in a restatement of our financial statements for prior periods. Any failure to implement and maintain effective internal control over financial reporting could also adversely affect the results of management reports and independent registered public accounting firm audits of our internal control over financial reporting that we will eventually be required to include in our periodic reports that will be filed with the SEC. Ineffective disclosure controls and procedures, and internal control over financial reporting could also cause investors to lose confidence in our reported financial and other information, which would likely have a negative effect on the market price of our common stock.

Our independent registered public accounting firm is not required to audit the effectiveness of our internal control over financial reporting until after we are no longer an “emerging growth company” as defined in the JOBS Act. At such time, our independent registered public accounting firm may issue a report that is adverse in the event it is not satisfied with the level at which our internal control over financial reporting is documented, designed or operating. Any failure to maintain effective disclosure controls and internal control over financial reporting could have a material and adverse effect on our business and operating results and cause a decline in the market price of our common stock.

Our failure to achieve and maintain effective internal control over financial reporting in accordance with Section 404 of the Sarbanes-Oxley Act as a public company could have a material adverse effect on our business and share price.

Prior to the completion of this offering, we have not had to independently comply with Section 404(a) of the Sarbanes-Oxley Act. Section 404(a) of the Sarbanes-Oxley Act requires annual management assessments of the effectiveness of our internal control over financial reporting, starting with the second annual report that we would expect to file with the SEC. We anticipate being required to meet these standards in the course of preparing our financial statements as of and for the period of inception (October 15, 2021) through December 31, 2022, and our management will be required to report on the effectiveness of our internal control over financial reporting for such year. Additionally, once we are no longer an emerging growth company, as defined by the JOBS Act, our independent registered public accounting firm will be required pursuant to Section 404(b) of the Sarbanes-Oxley Act to attest to the effectiveness of our internal control over financial reporting on an annual basis. The rules governing the standards that must be met for our management to assess our internal control over financial reporting are complex and require significant documentation, testing, and possible remediation.

Internal control over financial reporting is a process designed to provide reasonable assurance regarding the reliability of financial reporting and the preparation of financial statements in accordance with generally accepted accounting principles. We are in the process of reviewing, documenting, and testing our internal control over financial reporting, but we are not currently in compliance with, and we cannot be certain when we will be able to implement, the requirements of Section 404(a). We may encounter problems or delays in implementing any changes necessary to make a favorable assessment of our internal control over financial reporting. In addition, we may encounter problems or delays in completing the implementation of any public accounting firm after we cease to be an emerging growth company. If we cannot favorably assess the effectiveness of our internal control over financial reporting, or if our independent registered public accounting firm is unable to provide an unqualified attestation report on our internal controls after we cease to be an emerging growth company, investors could lose confidence in our financial information and the price of our common stock could decline.

Additionally, the existence of any material weakness or significant deficiency requires management to devote significant time and incur significant expense to remediate any such material weaknesses or significant deficiencies and management may not be able to remediate any such material weaknesses or significant deficiencies in a timely manner. The existence of any material weakness in our internal control over financial reporting could also result in errors in our financial statements that could require us to restate our financial statements, cause us to fail to meet our reporting obligations, and cause stockholders to lose confidence in our reported financial information, all of which could materially and adversely affect our business and share price.

For as long as we are an emerging growth company, we will not be required to comply with certain reporting requirements, including those relating to accounting standards and disclosure about our executive compensation, that apply to other public companies.

We are an “emerging growth company,” as defined in Section 2(a) of the Securities Act, as modified by the JOBS Act. As such, we are eligible to take advantage of certain exemptions from various reporting requirements that are applicable to other public companies that are not “emerging growth companies,” including, but not limited to, (i) not being required to comply with the auditor attestation requirements of Section 404(b) of the Sarbanes-Oxley Act, (ii) reduced disclosure obligations regarding executive

compensation in our periodic reports and proxy statements, and (iii) exemptions from the requirements of holding a non-binding advisory vote on executive compensation and of stockholder approval of any golden parachute payments not previously approved. We have elected to adopt these reduced disclosure requirements. We cannot predict if investors will find our common stock less attractive as a result of our taking advantage of these exemptions and as a result, there may be a less active trading market for our common stock and our stock price may be more volatile.

We could remain an “emerging growth company” for up to five years or until the earliest of (a) the last day of the first fiscal year in which our annual gross revenues exceed \$1 billion, (b) the date that we become a “large accelerated filer” as defined in Rule 12b-2 under the Exchange Act, which would occur if the market value of our common stock that is held by non-affiliates exceeds \$700 million as of the last business day of our most recently completed fiscal quarter, and (c) the date on which we have issued more than \$1 billion in non-convertible debt securities during the preceding three-year period.

We are also a “smaller reporting company” as defined in the Exchange Act, and have elected to take advantage of certain of the scaled disclosures available to smaller reporting companies. To the extent that we continue to qualify as a “smaller reporting company” as such term is defined in Rule 12b-2 under the Exchange Act, after we cease to qualify as an emerging growth company, certain of the exemptions available to us as an “emerging growth company” may continue to be available to us as a “smaller reporting company,” including exemption from compliance with the auditor attestation requirements pursuant to SOX and reduced disclosure about our executive compensation arrangements. We will continue to be a “smaller reporting company” until we have \$250 million or more in public float (based on our common stock) measured as of the last business day of our most recently completed second fiscal quarter or, in the event we have no public float (based on our common stock) or a public float (based on our common stock) that is less than \$700 million, annual revenues of \$100 million or more during the most recently completed fiscal year.

Our common stock price may be volatile or may decline regardless of our operating performance and you may not be able to resell your shares at or above the initial public offering price.

It is possible that after this offering an active trading market will not develop or continue or, if developed, that any market will be sustained, which could make it difficult for you to sell your shares of our common stock at an attractive price or at all. The initial public offering price of our common stock will be determined by negotiations between us and the representative of the underwriters based upon a number of factors and may not be indicative of prices that will prevail in the open market following the consummation of this offering. Consequently, you may not be able to sell our shares of common stock at prices equal to or greater than the price you paid in this offering.

Volatility in the market price of our common stock may prevent you from being able to sell your shares at or above the price you paid for them. Many factors, which are outside our control, may cause the market price of our common stock to fluctuate significantly, including those described elsewhere in this “Risk Factors” section and this prospectus, as well as the following:

- Our operating and financial performance and prospects;
- Our quarterly or annual earnings or those of other companies in our industry compared to market expectations;
- Conditions that impact demand for our products;
- Future announcements concerning our business or our competitors’ businesses;
- The public’s reaction to our press releases, other public announcements, and filings with the SEC;
- The size of our public float;
- Coverage by or changes in financial estimates by securities analysts or failure to meet their expectations;
- Market and industry perception of our success, or lack thereof, in pursuing our growth strategy;
- Strategic actions by us or our competitors, such as acquisitions or restructurings;
- Changes in laws or regulations that adversely affect our industry or us;
- Changes in accounting standards, policies, guidance, interpretations, or principles;
- Changes in senior management or key personnel;
- Issuances, exchanges or sales, or expected issuances, exchanges or sales of our capital stock;
- Changes in our dividend policy;
- Adverse resolution of new or pending litigation against us; and
- Changes in general market, economic, and political conditions in the U.S. and global economies or financial markets, including those resulting from natural disasters, terrorist attacks, acts of war, and responses to such events.

As a result, volatility in the market price of our common stock may prevent investors from being able to sell their common stock at or above the initial public offering price or at all. These broad market and industry factors may materially reduce the market price of our common stock, regardless of our operating performance. In addition, price volatility may be greater if the public float and trading volume of our common stock is low. As a result, you may suffer a loss on your investment.

Additionally, recently, securities of certain companies have experienced significant and extreme volatility in stock price due to short sellers of shares of common stock, known as a “short squeeze.” These short squeezes have caused extreme volatility in those companies and in the market and have led to the price per share of those companies to trade at significantly inflated rates that is disconnected from the underlying value of the company. Many investors who have purchased shares in those companies at an inflated rate face the risk of losing a significant portion of their original investment as the price per share has declined steadily as interest in those stocks have abated. While we have no reason to believe our shares would be the target of a short squeeze, there can be no assurance that we won’t be in the future, and you may lose a significant portion or all of your investment if you purchase our shares at a rate that is significantly disconnected from our underlying value.

You will suffer immediate and substantial dilution in the net tangible book value of the common stock you purchase.

The price you pay for shares of our common stock sold in this offering is substantially higher than our as adjusted net tangible book value per share. Based on the initial public offering price for our common stock of \$ per share (which is the midpoint of the price range set forth on the cover page of this prospectus), you will incur immediate dilution in net tangible book value per share of \$. Dilution is the difference between the offering price per share and the as adjusted net tangible book value per share of our common stock immediately after the offering. As a result of this dilution, investors purchasing stock in this offering may receive significantly less than the full purchase price that they paid for the stock purchased in this offering in the event of liquidation. See “Dilution.”

We do not intend to pay dividends on our common stock for the foreseeable future.

We presently have no intention to pay dividends on our common stock at any time in the foreseeable future. Any decision to declare and pay dividends in the future will be made at the discretion of our board of directors and will depend on, among other things, our results of operations, financial condition, cash requirements, contractual restrictions, and other factors that our board of directors may deem relevant. Furthermore, our ability to declare and pay dividends may be limited by instruments governing future outstanding indebtedness we may incur.

FINRA sales practice requirements may limit your ability to buy and sell our common shares, which could depress the price of our shares.

FINRA rules require broker-dealers to have reasonable grounds for believing that an investment is suitable for a customer before recommending that investment to the customer. Prior to recommending speculative low-priced securities to their non-institutional customers, broker-dealers must make reasonable efforts to obtain information about the customer’s financial status, tax status and investment objectives, among other things. Under interpretations of these rules, FINRA believes that there is a high probability such speculative low-priced securities will not be suitable for at least some customers. Thus, FINRA requirements may make it more difficult for broker-dealers to recommend that their customers buy our common shares, which may limit your ability to buy and sell our shares, have an adverse effect on the market for our shares and, thereby, depress their market prices.

Volatility in our common shares price may subject us to securities litigation.

The market for our common shares may have, when compared to seasoned issuers, significant price volatility, and we expect that our share price may continue to be more volatile than that of a seasoned issuer for the indefinite future. In the past, plaintiffs have often initiated securities class action litigation against a company following periods of volatility in the market price of its securities. We may, in the future, be the target of similar litigation. Securities litigation could result in substantial costs and liabilities and could divert management’s attention and resources.

We have broad discretion in the use of the net proceeds from this offering and may not use them effectively.

Our management has broad discretion in the application of the net proceeds from that offering, and you do not have the opportunity to assess whether the net proceeds are being used appropriately. Because of the number and variability of factors that will determine our use of the net proceeds from this offering, their ultimate use may vary substantially from their currently intended use. The failure by our management to apply those funds effectively could harm our business.

Provisions in our corporate charter documents and under Delaware law could make an acquisition of our company, which may be beneficial to our stockholders, more difficult and may prevent attempts by our stockholders to replace or remove our current management.

Provisions in our corporate charter and our bylaws may discourage, delay or prevent a merger, acquisition or other change in control of our company that stockholders may consider favorable, including transactions in which you might otherwise receive a premium for your shares. These provisions could also limit the price that investors might be willing to pay in the future for shares of our common stock, thereby depressing the market price of our common stock. In addition, because our board of directors is responsible for appointing the members of our management team, these provisions may frustrate or prevent any attempts by our stockholders to replace or remove our current management by making it more difficult for stockholders to replace members of our board of directors. Among other things, these provisions:

- our board of directors is divided into three classes, one class of which is elected each year by our stockholders with the directors in each class to serve for a three-year term;
- the authorized number of directors can be changed only by resolution of our board of directors;
- directors may be removed only by the affirmative vote of the holders of at least sixty percent (60%) of our voting stock, whether for cause or without cause;
- our bylaws may be amended or repealed by our board of directors or by the affirmative vote of sixty-six and two-thirds percent (66 2/3%) of our stockholders;
- stockholders may not call special meetings of the stockholders or fill vacancies on the board of directors;
- our board of directors will be authorized to issue, without stockholder approval, preferred stock, the rights of which will be determined at the discretion of the board of directors and that, if issued, could operate as a “poison pill” to dilute the stock ownership of a potential hostile acquirer to prevent an acquisition that our board of directors does not approve;
- our stockholders do not have cumulative voting rights, and therefore our stockholders holding a majority of the shares of common stock outstanding will be able to elect all of our directors; and
- our stockholders must comply with advance notice provisions to bring business before or nominate directors for election at a stockholder meeting.

Moreover, because we are incorporated in Delaware, we are governed by the provisions of Section 203 of the Delaware General Corporation Law, which prohibits a person who owns in excess of 15% of our outstanding voting stock from merging or combining with us for a period of three years after the date of the transaction in which the person acquired in excess of 15% of our outstanding voting stock, unless the merger or combination is approved in a prescribed manner.

Our Certificate of Incorporation provides that the Court of Chancery of the State of Delaware will be the exclusive forum for certain types of state actions that may be initiated by our stockholders, which could limit our stockholders’ ability to obtain a favorable judicial forum for disputes with us or our directors, officers, or employees

Our Certificate of Incorporation provides that, unless we consent to the selection of an alternative forum, the Court of Chancery of the State of Delaware is the exclusive forum for (i) any derivative action or proceeding brought on behalf of us, (ii) any action asserting a claim of breach of a fiduciary duty owed by any of our directors, officers, or other employees to us or our stockholders, (iii) any action arising pursuant to any provision of the DGCL or our certificate of incorporation or bylaws (as either may be amended from time to time), or (iv) any action asserting a claim governed by the internal affairs doctrine. The exclusive forum provision does not apply to suits brought to enforce any liability or duty created by the Securities Act or the Exchange Act or any other claim for which the federal courts have exclusive jurisdiction. To the extent that any such claims may be based upon federal law claims, Section 27 of the Exchange Act creates exclusive federal jurisdiction over all suits brought to enforce any duty or liability created by the Exchange Act or the rules and regulations thereunder. Furthermore, Section 22 of the Securities Act creates concurrent jurisdiction for federal and state courts over all suits brought to enforce any duty or liability created by the Securities Act or the rules and regulations thereunder.

These exclusive-forum provisions may limit a stockholder’s ability to bring a claim in a judicial forum that it finds favorable for disputes with us or our directors, employees,

control persons, underwriters, or agents, which may discourage lawsuits against us and our directors, employees, control persons, underwriters, or agents. Additionally, a court could determine that the exclusive forum provision is unenforceable, and our stockholders will not be deemed to have waived our compliance with the federal securities laws and the rules and regulations thereunder. If a court were to find these provisions of our bylaws inapplicable to, or unenforceable in respect of, one or more of the specified types of actions or proceedings, we may incur additional costs associated with resolving such matters in other jurisdictions, which could adversely affect our business, financial condition, or results of operations.

We presently intend to retain our earnings, if any, to finance the development and growth of our business and operations and do not anticipate declaring or paying cash dividends on our common stock in the foreseeable future.

Any future determination as to the declaration and payment of dividends, if any, will be at the discretion of our board of directors and will depend on then-existing conditions, including our operating results, financial condition, contractual restrictions, capital requirements, business prospects, and other factors our board of directors may deem relevant. See “Risk Factors — Risks Relating to This Offering and Ownership of Our Common Stock — We do not intend to pay dividends on our common stock for the foreseeable future” and “Description of Certain Indebtedness.”

USE OF PROCEEDS

We estimate that the net proceeds from our issuance and sale of shares of our common stock in this offering will be approximately \$ million, assuming an initial public offering price of \$ per share, which is the midpoint of the estimated offering price range set forth on the cover page of this prospectus, and after deducting the underwriting discounts and commissions and estimated offering expenses payable by us. If the underwriters exercise their option to purchase additional shares in full to cover overallocments, if any, we estimate that our net proceeds will be approximately \$ million.

A \$1.00 increase (decrease) in the assumed initial public offering price of \$ per share would increase (decrease) the aggregate net proceeds to us from this offering by approximately \$ million, assuming the number of shares offered by us, as set forth on the cover page of this prospectus, remains the same and after deducting underwriting discounts and commissions and estimated offering expenses payable by us. Similarly, each increase (decrease) of shares in the number of shares offered by us would increase (decrease) the net proceeds to us from this offering by approximately \$ million, assuming that the assumed initial public offering price remains the same, and after deducting the underwriting discounts and commissions and estimated offering expenses payable by us.

The principal purposes of this offering are to obtain additional capital to support our operations, establish a public market for our common stock and facilitate our future access to the public capital markets. We currently anticipate that we will use the net proceeds from this offering, together with our existing resources, as follows:

- approximately \$ for the design, development, testing, production and marketing of our electric boats;
- approximately \$ for the design, development, testing, production and marketing of our electric outboard motors;
- approximately \$ for the design, development, testing, manufacturing of our integrated control system;
- approximately \$ for the acquisition of property and the development of a manufacturing plant to build, design and manufacture our new line of electric boats.
- approximately \$ for the development of a vertically integrated direct-to-consumer distribution platform.
- the balance for working capital.

On July 23, 2021, Twin Vee consummated its initial public offering of 3,000,000 shares of its common stock at a public offering price of \$6.00 per share, generating gross proceeds of \$18,000,000 (the “Twin Vee IPO”). In connection with the Twin Vee IPO, Twin Vee stated that, among other things, it expected to use the net proceeds of the Twin Vee IPO as follows: (i) approximately \$2,500,000 for the design, development, testing, manufacturing and marketing of a new Twin Vee line of electric boats; (ii) approximately \$6,000,000 for the design, development, testing, manufacturing and marketing of a fully electric propulsion system; and (iii) \$3,500,000 for acquisition of waterfront property and development of an EV Innovation & Testing Center, in Fort Pierce, Florida to build, design and manufacture electric propulsion systems (the “EV Testing Center”).

Following the Twin Vee IPO, our parent company developed and tested the Twin Vee 280 Electric – 2.0 Prototype, which was a Twin Vee 28-foot gas-powered catamaran boat retrofitted with an electric propulsion system. After the successful sea trial of the Twin Vee 280 Electric – 2.0 Prototype, Twin Vee determined that it would make sense for it to develop a new multi-hull, catamaran design for its electric boats and not seek to retro-fit an electric propulsion system into a boat originally designed for a gas-engine, and that further, for branding purposes and to avoid confusion in the marketplace, to differentiate between its legacy Twin Vee gas-powered line of boats and the new line of electric boats it was developing by branding and marketing its new line of electric boats under a new brand name (and new subsidiary) separate and apart from Twin Vee. In October 2021 we were incorporated as a wholly-owned subsidiary of Twin Vee and Twin Vee transferred the entirety of its electric boat business to us.

To date, Forza X1 has received \$2,000,000 in capital contributions from Twin Vee which funds we have used for the design, development, testing, production and marketing of our electric boats and electric outboard motors. Until such time as we receive proceeds from this offering or we generate revenue from the sale of our electric boats, we anticipate that we will continue to receive funding from Twin Vee. By funding Forza X1, Twin Vee intends to use its IPO proceeds for the design, development, testing, production and marketing of electric boats and electric outboard motors and, by continuing its efforts to acquire a waterfront property in Fort Pierce, Florida for development of an EV Testing Center, Twin Vee intends to further support Forza X1. We have received increased indications of interest in our electric boats and based upon such increased interest, we believe that the Twin Vee manufacturing facility will not have sufficient capacity to allow for full scale production of Twin Vee’s gas powered boats and our electric boats and therefore a new electric boat manufacturing facility is needed, which was not anticipated at the time of the Twin Vee IPO. As a result of the increased capital markets interest in EV vehicles, the interest expressed by consumers for our electric boats and recent high-profile initial public offerings of EV vehicle companies which followed the Twin Vee IPO, Twin Vee determined that there may be an opportunity for Forza X1 to raise funds as a stand-alone entity through this Offering.

We believe opportunities may exist from time to time to expand our current business through acquisitions of, or investments in, complementary businesses, products or technologies. While we currently have no agreements or commitments to complete any such transaction at this time, we may use a portion of the net proceeds for these purposes.

The expected use of net proceeds from this offering represents our intentions based upon our current plans and business conditions, which could change in the future as our plans and business conditions evolve. The amounts and timing of our actual expenditures may vary significantly depending on numerous factors, including the progress of our development and any unforeseen cash needs. As a result, our management will retain broad discretion over the allocation of the net proceeds. We cannot specify with certainty all of the particular uses for the net proceeds to be received upon the closing of this offering.

Based on our current operational plans and assumptions, we expect that the net proceeds from this offering together with our existing cash and grant funding balances will be sufficient to fund our operating expenses and capital expenditure requirements for at least 12 months from the closing of this offering. We have based this estimate on assumptions that may prove to be incorrect, and we could use our available capital resources sooner than we currently expect. Pending use of the proceeds as described above, we intend to invest the proceeds in a variety of capital preservation investments, including interest-bearing, investment-grade instruments and U.S. government securities.

DIVIDEND POLICY

We presently intend to retain our earnings, if any, to finance the development and growth of our business and operations and do not anticipate declaring or paying cash dividends on our common stock in the foreseeable future.

Any future determination as to the declaration and payment of dividends, if any, will be at the discretion of our board of directors and will depend on then-existing conditions, including our operating results, financial condition, contractual restrictions, capital requirements, business prospects, and other factors our board of directors may deem relevant. See “Risk Factors — Risks Relating to This Offering and Ownership of Our Common Stock — We do not intend to pay dividends on our common stock for the foreseeable future” and “Description of Certain Indebtedness.”

CAPITALIZATION

The following table sets forth our cash and capitalization as of December 31, 2021, as follows:

- on an actual basis; and
- on an as adjusted basis to give further effect to our issuance and sale of shares of our common stock in this offering at an assumed initial public offering price of \$ per share, which is the midpoint of the price range set forth on the cover page of this prospectus, after deducting estimated underwriting discounts and commissions and estimated offering expenses payable.

	December 31, 2021	
	Actual	As Adjusted ⁽¹⁾
Cash and cash equivalents	\$ 1,803,285	—
Total Liabilities	\$ 645,378	
Stockholder’s equity:	6,500	
Common stock, par value \$0.001 per share; 25,000,000 shares authorized; 6,500,000 shares issued and outstanding, actual; 25,000,000 shares authorized, shares issued and outstanding, as adjusted;		
Additional paid-in capital	1,993,500	
Accumulated deficit	(412,551)	
Total stockholder’s equity	1,587,449	
Total liabilities and stockholder’s equity	\$ 2,232,827	

(1) The as adjusted balance sheet data in the table above reflects the sale and issuance by us of shares of our common stock in this offering, based upon the assumed initial public offering price of \$ per share, the midpoint of the price range set forth on the cover page of this prospectus, after deducting the underwriting discounts and commissions and estimated offering expenses payable by us.

Each \$1.00 increase (decrease) in the assumed initial public offering price of \$ per share, which is the midpoint of the estimated offering price range set forth on the cover page of this prospectus, would increase (decrease) our as adjusted cash, additional paid-in capital, total stockholders’ equity (deficit) and total capitalization by approximately \$ million, assuming the number of shares offered by us, as set forth on the cover page of this prospectus, remains the same, and after deducting underwriting discounts and commissions and estimated offering expenses payable by us. Each increase (decrease) of shares in the number of shares of common stock offered by us would increase (decrease) our as adjusted cash, additional paid-in capital, total stockholders’ equity (deficit) and total capitalization by approximately \$, assuming the assumed initial public offering price of \$ per share, which is the midpoint of the estimated offering price range set forth on the cover page of this prospectus, remains the same, and after deducting underwriting discounts and commissions and estimated offering expenses payable by us. The as adjusted information discussed above is illustrative only and will be adjusted based on the actual public offering price and other terms of this offering determined at pricing.

The number of shares of common stock that will be outstanding after this offering is based on shares of common stock outstanding as of December 31, 2021, and excludes the following:

- 1,000,000 shares of common stock reserved for future issuance under our 2022 Stock Incentive Plan, of which we will grant options to purchase an aggregate of shares of our common stock upon consummation of this offering.

DILUTION

If you invest in our common stock in this offering, your ownership interest will be diluted immediately to the extent of the difference between the initial public offering price per share of our common stock and the as adjusted net tangible book value per share of our common stock immediately after this offering.

Our historical net tangible book value (deficit) as of December 31, 2021 was \$1,587,449, or \$0.24 per share of our common stock. Our historical net tangible book value (deficit) is the amount of our total tangible assets less our total liabilities. Historical net tangible book value per share represents historical net tangible book value (deficit) divided by the number of shares of our common stock outstanding as of December 31, 2021.

After giving further effect to our issuance and sale of shares of common stock in this offering at an assumed initial public offering price of \$ per share, which is the midpoint of the estimated offering price range set forth on the cover page of this prospectus, and after deducting underwriting discounts and commissions, estimated offering expenses payable by us, our as adjusted net tangible book value as of December 31, 2021 would have been approximately \$, or approximately \$ per share. This represents an immediate increase in as adjusted net tangible book value per share of \$ to our existing stockholders and an immediate dilution in as adjusted net tangible book value per share of approximately \$ to new investors purchasing common stock in this offering. Dilution per share to new investors purchasing common stock in this offering is determined by subtracting as adjusted net tangible book value per share after this offering from the assumed initial public offering price per share paid by new investors.

The following table illustrates this dilution on a per share basis:

Assumed initial public offering price per share		\$
Historical net tangible book value (deficit) per share as of December 31, 2021	\$	0.24
Increase in as adjusted net tangible book value per share as of December 31, 2021		
As adjusted net tangible book value per share after this offering		
Dilution per share to new investors purchasing shares in this offering		\$

Each \$1.00 increase (decrease) in the assumed initial public offering price of \$ per share, which is the midpoint of the estimated offering price range set forth on the cover page of this prospectus, would increase (decrease) the as adjusted net tangible book value per share after this offering by \$ per share and the dilution to new investors purchasing common stock in this offering by \$ per share, assuming the number of shares offered by us, as set forth on the cover page of this prospectus, remains the same, and after deducting underwriting discounts and commissions and estimated offering expenses payable by us. An increase of shares in the number of shares offered by us would increase the as adjusted net tangible book value per share after this offering by \$ and decrease the dilution per share to new investors participating in this offering by \$, assuming no change in the assumed initial public offering price and after deducting underwriting discounts and commissions and estimated offering expenses payable by us. A decrease of shares in the number of shares offered by us would decrease the as adjusted net tangible book value per share after this offering by \$ and increase the dilution per share to new investors participating in this offering by \$, assuming no change in the assumed initial public offering price and after deducting underwriting discounts and commissions and estimated offering expenses payable by us.

If the underwriters exercise their option to purchase additional shares of common stock in this offering in full at the assumed initial public offering price of \$ per share, which is the midpoint of the estimated offering price range set forth on the cover of this prospectus, and assuming the number of shares offered by us, as set forth on the cover page of this prospectus, remains the same, and after deducting underwriting discounts and commissions and estimated offering expenses payable by us, the as adjusted net tangible book value per share after this offering would be \$ per share, and the dilution in as adjusted net tangible book value per share to new investors purchasing common stock in this offering would be \$ per share.

39

The number of shares of common stock that will be outstanding after this offering is based on shares of common stock outstanding as of December 31, 2021, and excludes the following:

- 1,000,000 shares of common stock reserved for future issuance under our 2022 Stock Incentive Plan, of which we will grant options to purchase an aggregate of shares of our common stock upon consummation of this offering.

To the extent that any outstanding options are exercised or new options are issued under the equity benefit plans, or we issue additional shares of common stock or convertible securities in the future, there will be further dilution to investors participating in this offering.

The following table summarizes, on an as adjusted basis as of December 31, 2021, after giving effect to the aggregate of shares of our common stock upon the closing of this offering, the total consideration paid or to be paid and the average price per share paid or to be paid by existing stockholders and by new investors in this offering at an assumed initial public offering price of \$ per share, which is the midpoint of the price range set forth on the cover page of this prospectus, before deducting estimated underwriting discounts and commissions and estimated offering expenses payable by us. As the table shows, new investors purchasing common stock in this offering will pay an average price per share substantially higher than our existing stockholders paid.

	Shares Purchased		Total Consideration		Weighted Average Price Per Share
	Number	Percent	Amount	Percent	
Existing stockholders before this offering	—	—%	\$ —	—%	\$ 4
Investors participating in this offering	—	—%	\$ —	—%	\$ —
Total	—	100%	\$ —	100%	\$ 5

The table above assumes no exercise of the underwriters' option to purchase additional shares in this offering. If the underwriters' option to purchase additional shares is exercised in full, the number of shares of our common stock held by existing stockholders would be reduced to % of the total number of shares of our common stock outstanding after this offering, and the number of shares of common stock held by new investors participating in the offering would be increased to % of the total number of shares outstanding after this offering.

40

MANAGEMENT'S DISCUSSION AND ANALYSIS OF FINANCIAL CONDITION AND RESULTS OF OPERATIONS

You should read the following discussion and analysis of our financial condition and results of operations together with our financial statements and the related notes to those statements included elsewhere in this prospectus. This discussion and analysis and other parts of this prospectus contain forward-looking statements based upon current beliefs, plans and expectations related to future events and our future financial performance that involve risks, uncertainties and assumptions, such as statements regarding our intentions, plans, objectives, expectations, forecasts and projections. Our actual results and the timing of selected events could differ materially from those anticipated in these forward-looking statements as a result of several factors, including those set forth under the section titled "Risk Factors" and elsewhere in this prospectus. You should carefully read the "Risk Factors" to gain an understanding of the important factors that could cause actual results to differ materially from our forward-looking statements. Please also see the section titled "Special Note Regarding Forward-Looking Statements."

Overview of Operations

Forza X1 Business

Forza X1, Inc. aims to be among the first to develop and manufacture electric boats targeting the recreational market. Our mission is to inspire the adoption of sustainable recreational boating by producing stylish electric sport boats. We are focused on the creation and implementation of marine electric vehicle ("EV") technology to control and power our electric boats utilizing our proprietary outboard electric motor. Our electric boats are being designed as fully integrated electric boats including the hull, outboard motor and control system.

To date, we have completed the design of the hull and running surface of the boat and have begun tooling the molds which are required to build the physical fiberglass boat, we have entered into a supply agreement for the supply of the lithium battery packs that we plan to use to power the electric boats, completed the design and prototyping of the boat control system, and completed the design and are halfway through prototyping of the electric outboard motor. We expect to begin production of our FX1 fully integrated electric boat and motor and commence selling to end user customers by the second quarter of 2023.

We believe that the boating industry will follow in the footsteps of the electrification of the automotive industry by creating electric boats that meet or exceed the traditional boating consumers expectations of price, value and run times. In other words, electric boats must offer a similar experience when compared to traditional gas powered boat in terms of size, capability and price point.

Our initial two models, the FX1 Dual Console and FX1 Center Console, are being designed to be 24-foot in length, have an 8' beam or width and utilize a catamaran hull surface to reduce drag and increase run times. The initial launch of FX1 will include our proprietary designed single electric outboard motor. Both FX1 models will have high-powered, liquid-cooled battery packs and a vehicle control unit with our proprietary control software all integrated into a 22" master control touch screen that will be used to control most functions of the boat. We have also filed three design and four utility patent applications with the U.S. Patent and Trademark Office relating to, among other things, our propulsion system being developed and boat design.

We plan to operate in a fundamentally different manner and structure than traditional marine manufacturers and boat dealers by adopting a direct-to-consumer sales model. We are building a dedicated web and app-based platform for sales, deliveries, and service operations to change the personal boat buying and marine service experience through technological innovation, ease of use, and flexibility. We intend to employ an integrated, digital-first strategy that is convenient and transparent for our customers and efficient and scalable to support our growth. We believe our approach will enable us to operate more cost-effectively, provide a better customer experience and incorporate customer feedback more quickly into our product development and manufacturing processes. We believe this strategy will allow us to deliver uncompromised and premium experiences well beyond what is available through the standard dealership model.

Results of Operations and Known Trends or Future Events

The following table provides certain selected financial information for period from inception (October 15, 2021) to December 31, 2021:

	December 31,	
	2021	
Net sales	\$	—
Cost of products sold	\$	—
Gross profit	\$	—
Operating expenses	\$	336,528
Loss from operations	\$	(336,528)
Other expense	\$	76,023
Net loss	\$	(412,551)
Basic and dilutive income per share of common stock		(0.06)
Weighted average number of shares of common stock outstanding		6,500,000

Prior to our inception (October 15, 2021), Twin Vee dedicated resources to designing and building prototype electric boats. These resources and expenditures were segregated in Twin Vee's financial statement and have been allocated to Forza X1 and are included in our financial statements as of and for the period of inception (October 15, 2021) through December 31, 2021.

To date all of our operational activity has been related to the design and build of prototype, as such we do not have sale or cost of goods sold. The design of our new electric boat shell has been completed and we are now preparing to begin our production process by securing molds for the FX1 line. The design on the control system will continue as we move forward. To date we have not generated any revenues. Other than designing and building the prototype our only other activities since inception (October 15, 2021) have been organizational and activities and those necessary to prepare for this offering. Following this offering, we will not generate any operating revenues until we complete the design and build of our EV boats and commercialize them. We will generate non-operating income in the form of interest income on cash and cash equivalents after this offering. After this offering, we expect to incur increased expenses as a result of being a public company (for legal, financial reporting, accounting and auditing compliance). In addition, we expect our expenses to increase substantially after the closing of this offering for expenses associated with building a new manufacturing facility.

Operating Expenses

Operating expenses for the period of inception (October 15, 2021) through December 31, 2021 were \$336,528. Operating expenses include salaries, selling and general and administrative, research and development, professional fees and depreciation. Research and development fees were \$211,111, making up 63% of our operating expenses. Salaries and wages of \$41,189, relate to the design of our fully electric motor, accounting for another 12% of our total operating expenses. Our expenses for selling, general and administrative for the period of inception (October 15, 2021) through December 31, 2021, were \$40,761. Depreciation and professional fees totaled \$43,467 for the period of inception (October 15, 2021) through December 31, 2021.

Other expense

During the period from inception (October 15, 2021) through December 31, 2021, we incurred losses on the disposal of assets which was partially offset by a gain from insurance recovery, which netted to (\$60,252). Interest expense of \$15,771 for the period from inception (October 15, 2021) through December 31, 2021, was the remainder of our other expenses.

Liquidity and Capital Resources

The following table provide selected financial data about us for the period of inception (October 15, 2021) through December 31, 2021:

Cash and cash equivalents	\$	1,803,285
Current assets	\$	1,891,762
Current liabilities	\$	645,378
Working capital	\$	1,246,384

As of December 31, 2021, we had cash and cash equivalents, and working capital of \$1,803,285 and \$1,246,384, respectively. To date, our sole source of funding has been from Twin Vee. Twin Vee has financed our working capital needs, primarily prototyping, consulting services, rent, interest and payroll through a \$2,000,000 equity investment. In addition, Twin Vee has provided management services to us for a monthly fee of \$5,000. Additionally, we are allowed to use space at its facility for a monthly cost of \$850. We expect to continue to use the management services of Twin Vee until such time as we are able to secure additional financing and fully build our own management team and we expect to continue to rent space from Twin Vee until we have built our own manufacturing facility. We have incurred and expect to continue to incur significant costs in pursuit of our financing and construction of our new manufacturing facility. Our management plans to use the proceeds from this offering to finance these expenses. We believe that our current capital resources, together with net proceeds of this offering, will be sufficient to fund our operations and growth initiative for at least 18 months following

consummation of this offering. The Company expects to continue to incur net losses and have significant cash outflows for at least the next 12 months. However, we believe that our current capital resources are sufficient to fund our operations through the consummation of this offering. Following the offering, if we do not generate cash flows sufficient to fund operations as planned, we may need to raise additional capital through the sale of equity or debt securities or through asset-related sales transactions. We cannot be certain that any such transaction will be available to us on commercially reasonable terms or at all as and when required.

Cash Flow

The following table provides selected financial data about us for the period of inception (October 15, 2021) through December 31, 2021.

43

Cash Flow from Operating Activities

During the period of inception (October 15, 2021) through December 31, 2021, we generated negative cash flows from operating activities of \$259,107. During this period, we had a net loss of \$412,551, and our cash used in operating activities was increased by prepaid expense of \$88,477 and decreased by non-cash expenses of \$193,460 primarily related to the loss on disposal of assets and reduced by a net change in working capital of \$48,461.

Cash Flows from Investing Activities

For the period of inception (October 15, 2021) through December 31, 2021, we used \$429,025 in investing activities for the purchase of property and equipment.

Cash Flows from Financing Activities

To date, we have financed our operations primarily from capital provided from Twin Vee in the form of an equity investment and advances. During the period of inception (October 15, 2021) through December 31, 2021, net cash provided by financing activities was \$2,491,417, with \$2,995,547 provided from Twin Vee as an advance and a capital contribution, which was offset by repayment of advance of \$398,630 and deferred IPO costs of \$105,500. The advances bear interest at the rate of 6% per annum and during the period of inception (October 15, 2021) through December 31, 2021, we accrued \$15,771 in interest expense.

Critical Accounting Policies and Significant Judgement and Estimates

This discussion and analysis of our financial condition and results of operations is based on four financial statements, which have been prepared in accordance with generally accepted accounting principles in the United States, or GAAP. The preparation of these financial statements requires us to make estimates and assumptions that affect the reported amounts of assets and liabilities and the disclosure of contingent assets and liabilities at the date of the financial statements, as well as the reported expenses incurred during the reporting periods. Our estimates are based on our historical experience and on various other factors that we believe are reasonable under the circumstances, that results of which form the basis for making judgments about the carrying value of assets and liabilities that are not readily apparent from other sources. Actual results may differ from these estimated under different assumption or conditions. While our significant accounting policies are described in more detail in the notes to our financial statements included elsewhere in the prospectus, we believe that the following accounting policies are critical to understanding our historical and future performance, as these policies relate to the more significant areas involving managements judgements and estimates.

Controls and Procedures

We are not currently required to maintain an effective system of internal controls as defined by Section 404 of the Sarbanes-Oxley Act. We will be required to comply with the internal control over financial reporting requirements of the Sarbanes-Oxley Act for the twelve-month period ending December 31, 2022. Only in the event that we are deemed to be a large accelerated filer or an accelerated filer, and no long qualify as an emerging growth company, would we be required to comply with the independent registered public accounting firm attestation requirement. Further, for as long as we remain an emerging growth company as defined in the JOBS Act, we intend to take advantage of certain exemptions from various reporting requirements that are applicable to other public companies that are not emerging growth companies including, but not limited to, not being required to comply with the independent registered public accounting firm attestation requirement.

Use of Estimates

The preparation of financial statements in conformity with accounting principles generally accepted in the United States ("U.S. GAAP") required management to make estimates and assumptions that affect the amounts reported in the financial statements. Actual results could differ from those estimates. Included in those estimates are assumptions about useful life of fixed assets.

Cash and Cash Equivalents

Cash and cash equivalents include all highly liquid investments with original maturities of three months or less at the time of purchase. On December 31, 2021, the Company had cash and cash equivalents of \$1,803,285.

44

Property and Equipment

Property and equipment are stated at cost. Depreciation is provided using the straight-line method over the estimated useful lives of the related assets. The estimated useful lives of property and equipment range from three to seven years. Upon sale or retirement, the cost and related accumulated depreciation and amortization are eliminated from their respective accounts, and the resulting gain or loss is included in results of operations. Repairs and maintenance charges, which do not increase the useful lives of the assets, are charged to operations as incurred.

Impairment of Long-lived Assets

Management assesses the recoverability of its long-lived assets when indicators of impairment are present. If such indicators are present, recoverability of these assets is determined by comparing the undiscounted net cash flows estimated to result from those assets over the remaining life to the assets' net carrying amounts. If the estimated undiscounted net cash flows are less than the net carrying amount, the assets would be adjusted to their fair value, based on appraisal or the present value of the undiscounted net cash flows.

Research and Development

Research and development costs are expensed when incurred. Such costs approximated \$211,111 for the period of inception (October 15, 2021) through December 31, 2021.

Advertising Costs

Advertising and marketing costs are expensed as incurred. For the period of inception (October 15, 2021) through December 31, 2021, advertising and marketing costs incurred by the Company totaled \$7,130, and are included in selling and general and administrative expenses in the accompanying statements of operations.

Income Taxes

The Company is a C Corporation under the Internal Revenue Code and a similar section of the state code.

All income tax amounts reflect the use of the liability method under accounting for income taxes. Income taxes are provided for the tax effects of transactions reported in the financial statements and consist of taxes currently due plus deferred taxes arising primarily from differences between financial and tax reporting purposes.

Deferred income taxes, net of appropriate valuation allowances, are determined using the tax rates expected to be in effect when the taxes are actually paid. Valuation allowances are recorded against deferred tax assets when it is more likely than not that such assets will not be realized. When an uncertain tax position meets the more likely than not recognition threshold, the position is measured to determine the amount of benefit or expense to recognize in the financial statements.

In accordance with U.S. GAAP, the Company follows the guidance in FASB ASC Topic 740, Accounting for Uncertainty in Income Taxes. At December 31, 2021, the Company does not believe it has any uncertain tax positions that would require either recognition or disclosure in the accompanying financial statements.

The Company's income tax returns are subject to review and examination by federal, state and local governmental authorities.

Recent Accounting Pronouncements

All newly issued accounting pronouncements not yet effective have been deemed either immaterial or not applicable.

Internal Control Over Financial Reporting

Internal control over financial reporting is a process designed to provide reasonable assurance regarding the reliability of financial reporting and the preparation of financial statements in accordance with U.S. GAAP. Under standards established by the Public Company Accounting Oversight Board, or PCAOB, a deficiency in internal control over financial reporting exists when the design or operation of a control does not allow management or personnel, in the normal course of performing their assigned functions, to prevent or detect misstatements on a timely basis. The PCAOB defines a material weakness as a deficiency, or combination of deficiencies, in internal control over financial reporting, such that there is a reasonable possibility that a material misstatement of annual or interim financial statements will not be prevented, or detected and corrected, on a timely basis.

In accordance with the provision of the JOBS Act, we and our independent registered public accounting firm were not required to, and did not, perform an evaluation of our internal control over financial reporting as of December 31, 2021, nor any period subsequent in accordance with the provisions of the Sarbanes-Oxley Act. However, while preparing the financial statements, we identified material weaknesses in our internal control over financial reporting such that there is a reasonable possibility that a material misstatement of our annual or interim financial statements will not be prevented or detected on a timely basis.

The material weaknesses identified pertain to controls that address segregation of duties across financially relevant functions and applications used in financial reporting. We have concluded that these material weaknesses existed because, as a small company, we did not have the necessary business processes, systems, personnel, and related internal controls necessary to satisfy the accounting and financial reporting requirements of a public company. The deficiencies identified did not result in a misstatement to our financial statements.

We are in the process of implementing measures designed to improve our internal control over financial reporting to remediate these material weaknesses. The Company's plan to remediate the material weakness in its internal control over financial reporting includes utilizing a portion of the working capital from its initial public offering to increase staffing with its finance department sufficient to facilitate proper segregation of accounting functions and to enable appropriate review of its internally prepared financial statements.

Prior to the closing of this offering, we have not completed an assessment, nor has our independent registered public accounting firm tested our systems, of internal controls over financial reporting.

JOBS Act

The JOBS Act permits an emerging growth company such as us to take advantage of an extended transition period to comply with new or revised accounting standards applicable to public companies until those standards would otherwise apply to private companies. We have elected to avail ourselves of the extended transition period for complying with new or revised financial accounting standards.

We will remain an emerging growth company until the earliest of (i) the last day of our first fiscal year in which we have total annual gross revenues of \$1.07 billion or more; (ii) the date on which we are deemed to be a "large accelerated filer" under the rules of the SEC with at least \$700.0 million of outstanding equity securities held by non-affiliates; (iii) the date on which we have issued more than \$1.0 billion in non-convertible debt securities during the previous three years; or (iv) the last day of our fiscal year following the fifth anniversary of the date of the completion of this offering.

Quantitative and Qualitative Disclosures About Market Risk

As a smaller reporting company, we are not required to provide disclosure regarding quantitative and qualitative market risk.

BUSINESS

Overview

About Forza X1

Forza X1, Inc. ("Forza X1" "we" "us" or the "Company") aims to be among the first to develop and manufacture electric boats targeting the recreational market. Our mission is to inspire the adoption of sustainable recreational boating by producing stylish electric sport boats. We are focused on the creation and implementation of marine electric vehicle

("EV") technology to control and power our electric boats utilizing our proprietary outboard electric motor. Our electric boats are being designed as fully integrated electric boats including the hull, outboard motor and control system.

To date, we have completed the design of the hull and running surface of the boat and have begun tooling the molds which are required to build the physical fiberglass boat, we have entered into a supply agreement for the supply of the lithium battery packs that we plan to use to power the electric boats, completed the design and prototyping of the boat control system, and completed the design and are halfway through prototyping of the electric outboard motor. We expect to begin production of our FX1 fully integrated electric boat and motor and commence selling to end user customers by the second quarter of 2023.

We believe that the boating industry will follow in the footsteps of the electrification of the automotive industry by creating electric boats that meet or exceed the traditional boating consumers expectations of price, value and run times. In other words, electric boats must offer a similar experience when compared to traditional gas-powered boat in terms of size, capability and price point.

We currently are a wholly-owned subsidiary of Twin Vee Powercats Co. Prior to our incorporation in October 2021, we operated as the Electra Power Sports™ Division of Twin Vee. With increased indications of interest received by Twin Vee for electric vehicles, Twin Vee determined that we should be a stand-alone entity and transferred the entirety of its electric boat business to us.

First FX1 Models

Forza X1, working with naval architect Albert Nazarov and his company, Albatross Marine Design, have completed the designs of Forza X1's first boat, the FX1. Unlike the two prototypes developed by Twin Vee, the FX1 model will not be a retrofitted Twin Vee catamaran hull with an electric propulsion system. Instead, the FX1 model is being built based on an entirely new design that will incorporate the same control system as the second prototype.

Our initial two models, the FX1 Dual Console and FX1 Center Console, are being designed to be 24-foot in length, have an 8' beam or width and utilize a catamaran hull surface to reduce drag and increase run times. The initial launch of FX1 will include our proprietary single electric outboard motor. Both FX1 models are being designed with advanced high-powered, liquid-cooled lithium battery packs that will be provided by the third party supplier with whom we have entered into a five year supply agreement and a vehicle control unit with proprietary control software all integrated into a 22" master control touch screen that will be used to control most functions of the boat. We have also filed three design and four utility patent applications with the U.S. Patent and Trademark Office relating to, among other things, our propulsion system being developed and boat design.

Forza X1: An All Digital , Direct-to Consumer Platform

We intend to offer our EV products, services and support through a Web-based and mobile phone App that will be vertically integrated and a direct-to-consumer platform. Over the last couple of years, non-contact consumerism has brought shopping and customer service experiences to a new level that will likely remain prevalent long after the COVID-19 pandemic. We intend to create a high quality customer experience that spans the entire life of our products through an online system that is being designed to be comprehensive, seamless, and efficient for a customer experience.

Forza X1 plans to utilize a web-based and app platform to connect with customers for an end-to-end experience encompassing everything from buying, financing, delivery, servicing, and training. We have commenced the design of the web-based platform but have not yet commenced design of the app. This customer-centric approach to sales and service aims at simplifying access to necessary information for potential buyers and current owners alike. Customers will be able to communicate directly with Forza X1 to ensure their questions are answered and their needs are met.

Currently, Forza X1's web and app-based platform is expected to include the following:

- **Build and Price Boats.** The web and app platform will offer prospective buyers a place to examine photos and videos of our boats, which will all have a single price based on the model type and a few available options. For example, the consumer would have four gel coat exterior choices, three interior upholstery choices, and an option to increase the battery pack capacity for extended run times. Other options would include charging cords and plugs, boating items such as bumpers, covers, and fun add-ons like clothing, allowing consumers to "personalize" their Forza X1 purchase.
- **Financing.** Prospective customers will be able to apply for third-party consumer financing to complete or supplement their purchase through Forza X1's web and app platform.
- **Delivery.** Once manufactured, the boat will be delivered directly to a customer's home, marina, or wherever they choose. The scheduling, communication, and support necessary for coordinating touchless delivery of our Forza X1 boats would all be accomplished over the website or app.

- **Servicing.** We intend to offer highly tailored and differentiated services that enable intuitive experiences throughout the entire customer lifecycle, such as warranty, repair, or other service assistance for their boats. We expect this all-inclusive approach will provide higher customer satisfaction, create strong brand loyalty, and increase operational efficiency while simultaneously allowing us to capture a more significant share of the entire lifecycle value of every Forza X1 boat produced. We anticipate having internal staff with the capability to provide an OTA update to resolve the issue remotely without the boat ever leaving the customer's sight. As part of our customer satisfaction drive, we plan for our staff to make mobile service calls to the boat docks. We also intend to enter into partnering arrangements with third parties to address service needs that require more than a mobile service visit, and we plan to arrange for the boat to be picked up and brought to one of our partnered service centers. If a service center is not available in a customer's area, then Forza X1 will permit the owners to take their boat to their local service center who will then invoice us.
- **Customer Service and Feedback.** We will utilize customer insights and feedback submitted via our web and app-based platform to improve our offerings by adding new capabilities and functionality. Expanded offerings based on consumer-driven feedback and data is expected to attract more customers, deepen existing customer relationships, and allow us to innovate more quickly.
- **Training.** Forza X1 intends to provide a series of videos that demonstrate our boats' safe operation and upkeep. These videos would be accessible on our web and app platform and the boat's onboard computer for quick access.

Forza X1 Purpose

According to the Environmental Energy Student Institute, a non-profit organization originally formed by a bipartisan group of members of Congress, fossil fuels, including coal, oil, and natural gas, have been powering economies for over 150 years and currently supply about 80 percent of the world's energy. When fossil fuels are burned, the stored carbon and other greenhouse gases are released into the atmosphere. The excess buildup of greenhouse gases in the atmosphere has caused dramatic changes to Earth's climate—a trend that will worsen as more fossil fuels are burned. Further climate changes may cause rises in sea level, extreme weather, biodiversity loss, and species extinction, as well as food scarcity, worsening health, and poverty for millions of people worldwide.

The world's waterways are also in danger from pollutants caused by gas-powered motors. In the landmark environmental study and book, "Polluting for Pleasure", author Andre Mele stated that recreational boats, particularly outboards, were polluting as much as all the cars and trucks in America. At the time, Mele discovered that pleasure boats have polluted 80 times more than automobile engines and put more oil into American waters than 15 Exxon Valdez oil spills, annually. The popularity of recreational boating has grown since then.

While headway is being made by the automotive industry introducing more viable EV options to replace traditional automobiles, it is also vital that we look to preserve our waterways while reducing carbon emissions. Large gas-powered engines often leak fuel and produce carbon emissions, both of which are harmful to fragile marine ecosystems. We are a company comprised of people who are passionate to move the preservation and carbon free marine lifestyle forward. According to the Bloomberg NEF's 2021 Electric Vehicle Outlook, passenger automotive EV sales are set to increase from 3.1 million units in 2020 to 14 million units in 2025.

Forza X1 aims to manufacture electric boats with a proprietary electric outboard motor that has been designed and integrated with our own control system. The Forza X1 boats are being designed for the production of a combined boat and motor package, along with our control system that we intend to market and sell as a single package. Our Forza X1 boat is intended to work seamlessly and offer families and water recreation enthusiasts an enjoyable time for an affordable price.

Our core market corresponds most directly to those who identify with environmentally friendly vehicles. Electric boats promote environmental sustainability and allow for a much more serene and enjoyable time on the water. The adoption of electric vehicles has increased considerably over the years as they are more environmentally friendly. As per the report by Bloomberg NEF, there are currently 12 million passenger EVs on the road, and the prevalence of electric-powered boats is likely to follow suit. While electric boats only represented about 2% of the market in 2020, a report by IDTechEx shows that the market for hybrid and pure electric boats is expected to rise rapidly to greater than \$20 billion worldwide by 2027, finding that recreational boats is the largest and fastest growing electric marine market in sales number.

Forza X1 plans to disrupt recreational marine customs that rely on outdated processes and noxious engines by designing, engineering and manufacturing inspiring electric boats that operate in a more sustainable and eco-friendly way.

240 Electric – Prototype

The first prototype of the electric boat, the 240 Electric, was developed by Twin Vee and publicly announced on December 18, 2020. Wanting to expand its offering to include electric-powered boats, Twin Vee created its Twin Vee Electric division. Twin Vee Electric sought to retrofit a Twin Vee-branded 24-foot center console boat and enable it to run on a bank of lithium-ion batteries. The team worked almost a year designing and developing the first prototype electric boat.

In early May 2021 the first prototype was tested in the Indian River near North Hutchinson Island in Fort Pierce, Florida. The initial prototype failed its testing due to a fire that started during testing, resulting in the creation of the second prototype with an improved control system.

Successful testing and sea trial of Forza's
100% Electric Prototype Catamaran



November 1st, 2021



280 Electric – 2.0 Prototype

The second prototype, which was a 28-foot Twin Vee retrofitted catamaran was built by Twin Vee with an improved control system, which is the same control system that we intend to install in the electric boats that we are currently designing for mass production.

The 280E electric boat consists of two (2) in-board motors with a comprehensive system of control device, display, two lever throttle, touchscreen display, an all-new 86KWH Battery pack, IDU J-box Micro Controller, High Power distribution unit, inverter and motor, and onboard charger as shown in figure 1 & 2. We intend to use a similar main console for the Forza FX1.

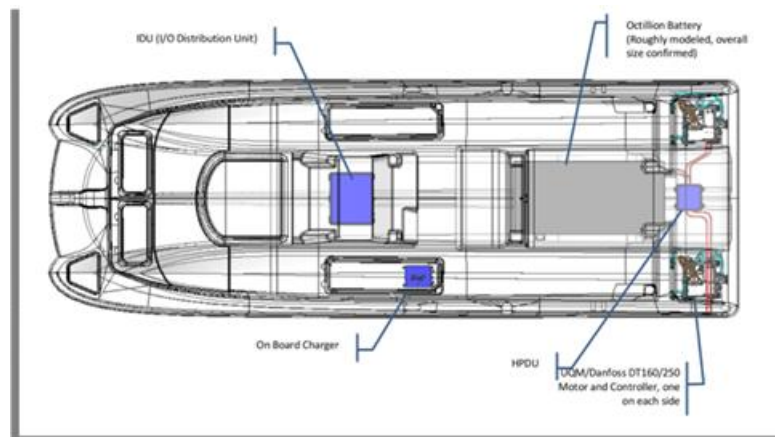

Figure 1: Electric Boat Prototype system components overview top view

The main console consists of a dual lever throttle, display and a key switch. The boat speed control function is activated by deflecting the friction throttle lever forward or reverse. Deflecting the throttle handle sends a control signal to the Microcontroller, which sends the digital signal over CANBUS to the inverter, which provides the energy flow path from battery pack to the motor, thus turning the propeller. The throttle function uses a cruise control feature, which enables the system to automatically adapt to a set speed, operating the battery efficiently as possible without manual intervention.

The key switch in the control system activates the main electrical systems (i.e., the battery pack, Inverter, OBC) for the boat, including the accessories, such as the bilge pump, horn, hatch control, etc.

The display is a comprehensive system (Battery and Inverter Data) utilizing control software that goes beyond simple monitoring. With the display, the operator gets the additional functionality of alerts. Alerts allow the boat's operator to setup as many warnings and alarms as they may need so they can be forewarned of potential problems. Additionally, the control functionality provides operators with the ability to manage the electrical system.

The IDU J-box is plug and play for easy installation, which contains the main controller connecting pumps for different cooling systems as well as the battery pack, onboard charger, and inverter to control the boat speed. The panel is completely electrical based on 24 VDC volts from the boat's electrical supply. The IDU J-box is installed under the console for ease of access. The battery pack is connected over the CANBUS network with the IDU microcontroller.

Catamaran Technology –Reduced Drag and Extended Run Times

Forza X1 plans to utilize a newly designed multi-hull, catamaran design for its FX1 boat. There is a multitude of benefits for catamaran multi-hulled boats, including better performance, two narrow hulls generate about one-third as much wetted-surface or drag, reduced hydrodynamic resistance allowing for more speed or requiring less power to operate.

Catamarans also ride softer because they don't have a large, round bottom that slams against the waves. In other words, the reduced vertical accelerations on the water from a multi-hull boat helps prevent slamming for a smoother ride.

Additional advantages of a multi-hull boat is better stability and an increased level of safety, higher freeboard and flotation. Lastly, multi-hull boats provide a superior amount of comfort for passengers. There is typically plenty of space and accommodations on deck with a catamaran that is difficult to replicate on monohulls.

Unlike the two prototypes developed by Twin Vee, the FX1 model we are designing will not be a retrofitted Twin Vee catamaran. Although the FX1 model is being designed to incorporate the same control system as the second prototype, the FX1 model is being built based on an entirely new design developed for us by naval architect Albert Nazarov and his company, Albatross Marine Design.

Dimensioning of Catamarans – Parametric Approach

Naval architect Albert Nazarov and his company, Albatross Marine Design, have designed Forza's FX1 boat with mathematical precision. The base system of design equations describing the design can be written as following:

$$\left. \begin{aligned} \sum v_i &\leq v_A \\ M &= \rho g V \\ v_s &\geq [v_s]_R \\ r &\geq [r]_R \\ \frac{a_{CG}}{g} &\leq \left[\frac{a_{CG}}{g} \right]_{\max} \\ S &\rightarrow \min \end{aligned} \right\}$$

Where first equation is relation of sum of required volumes v_i and available volume v_A ; second equation is balance of craft mass M and volume displacement V ; third and fourth are comparisons of design speed v_s , and range r with required speed $[v_s]_R$ and range $[r]_R$. Fifth equation specifies condition of seakeeping as not exceeding certain acceleration level a_{CG}/g . Last equation is criteria of minimization of construction cost S , though operational costs might be considered for complete analysis. Stability condition is excluded from preliminary analysis of catamarans.

Forza X1 Outboard Motor



Motor Power Equivalent (HP)	150	
	Cont	Peak
Propeller Torque (Nm)	160	320
Motor Power (kW)	100	135
Propeller Speed (RPM)	10,000	
Motor Weight Approx (Kg)	65	
System Weight Approx (Kg)	1,000 (motor + batteries)	
Range @ 25 knots	1 to 4 hrs	
Steering	Up to 360 Degree Integrated Electronic Control	
Battery Type	Lithium Ion Rechargeable	
Throttle	Electronic	
Controller	Integrated	
User Display	Custom, Touchscreen	
Charger	SAE J1772 Type 1 	

Figure 3 - Current specifications of the system

Outboard Design

The outboard system is designed with modular sub systems. The subsystems connect to a central upper assembly in a common way so that development task management and subsequent engineering activities can take place concurrently if needed. The subsystems include steering, cooling, lower POD drive units, trim and tilt, and cover assemblies.

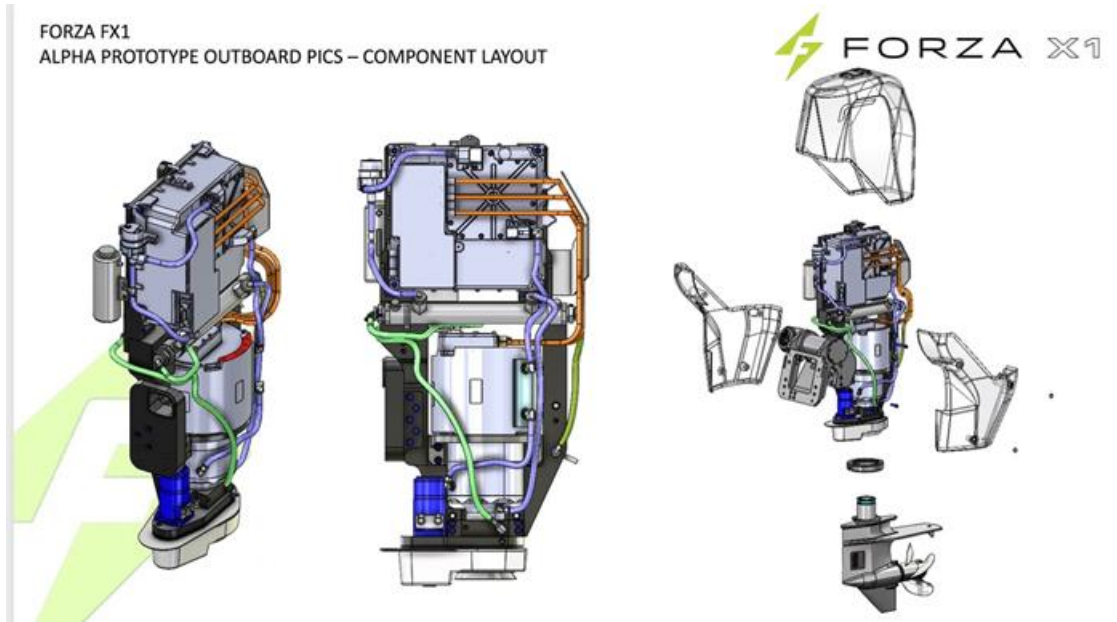

Core Motor and Gear Reducer Information

The motor is the heart of the entire outboard drive system. Because its output RPM is up to 10,000 RPM it must be reduced to achieve the proper torque on the output propeller. To accomplish this the Forza X1 team had to develop a proprietary custom gear reducer which is incorporated in the core motor. This gear reducer features a two-stage planetary gear assembly with an overall 1.9:1 ratio. The planetary gear reducer is designed to accommodate vertical orientation which is ideal for mounting inside the Forza X1 Outboard.

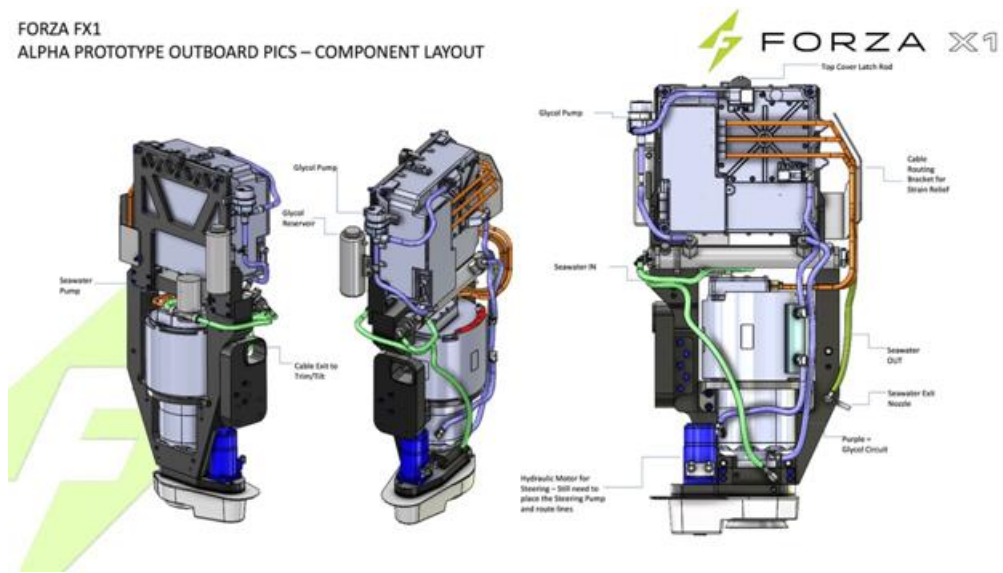

A compliant shaft coupler connects the output shaft of the gear reducer to the lower drive unit which is illustrated in the following sections. The shaft coupler includes a compliant membrane which is engineered to accommodate torsional continuous loads as well as sudden “shock” loads which may occur when reversing shaft rotation. The output shaft is fed through the slewing bearing steering assembly. This is a unique design for outboards for which we filed a design patent application on December 10, 2021, which application is currently pending approval.

Upper Assembly

The upper assembly is the central “torso” of the outboard structure. It houses the main core motor and gear reducer, as well as provides a modular mounting structure for the motor controller, cooling system, steering system, trim and tilt as well as the covers.

The upper assembly is being designed to be made from 6061-T6 aircraft grade aluminum alloys. The Trim/Tilt mount is attached to the upper frame block with 5 M12 high strength socket head cap screws as well as 3 supporting M10 socket head cap screws. The mount features a cross pattern which will support and distribute the load for the entire weight of the outboard, as well as transmit the static stress loads through the structure while under operation.

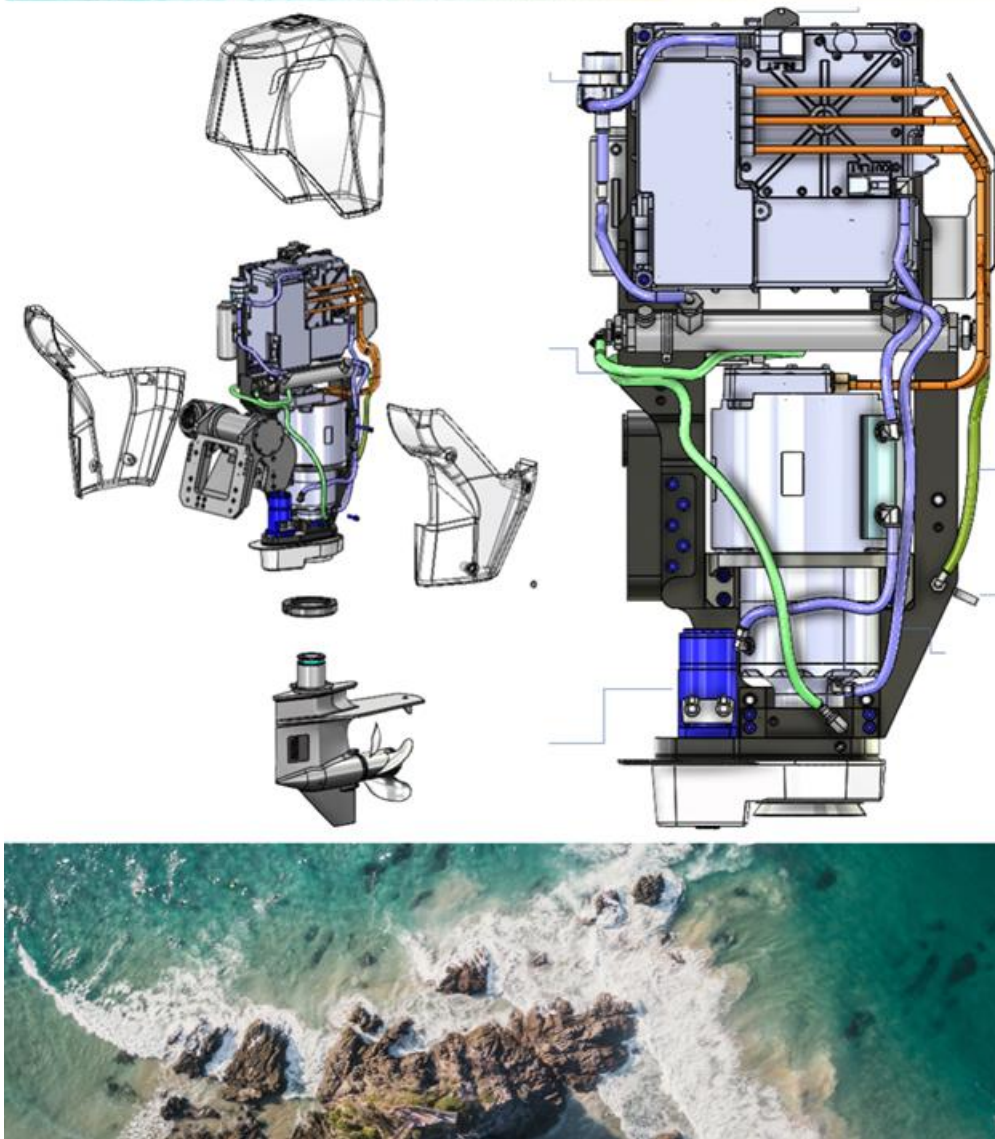

The central frame design is also proprietary in that it allows for an easy vertical mounting of the core motor assembly but also allows the entire core motor assembly to be removed from one side of the outboard, without a complete teardown of the system. The shape of the uni-body profile includes engineered clearance to accommodate the rare occasion of a motor needing extended service and replacement. We have filed a design patent application for the design of the central frame, which application is currently pending approval.

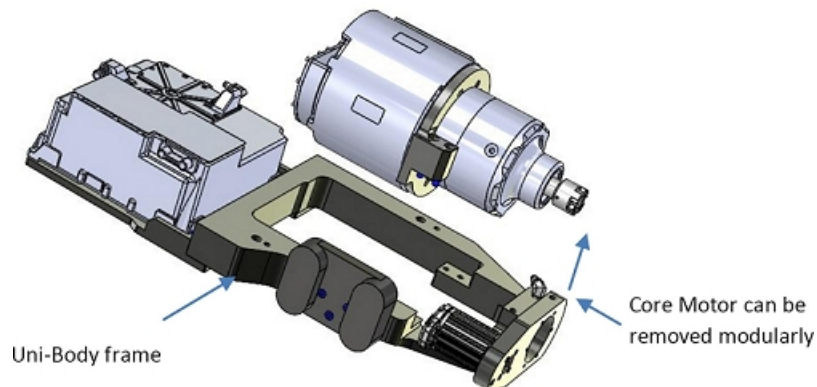

The motor controller frame attaches to the uni-body frame with a set of M8 socket head cap screws. The frame is CNC machined, like the uni-body structure, however it is designed to be removed and replaced as needed as the design of the system matures.

Steering System

The steering system is novel. It incorporates slew bearing technology that is proven in heavy equipment, wind turbines, and military systems, and combines it with custom gearing, and a coupling interface with the lower POD drive unit. This mechanical steering system in combination with electronically controlled power steering from the helm results in up to 360-degree POD rotation for the lower unit. The upper assembly for the outboard is fixed which is designed to keep the center of gravity stable at high-speed turning, and the 360-degree power steering is expected to result in an un-matched user experience to make boat docking and maneuvering easier than ever before.

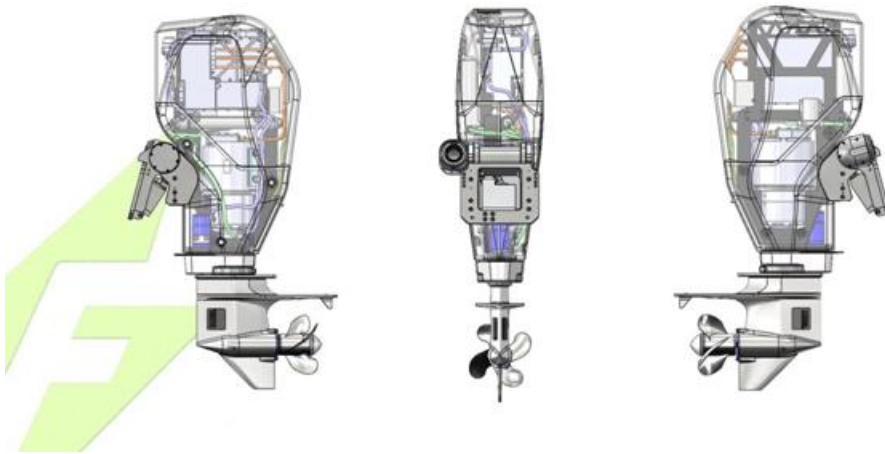

58

The slewing bearing assembly is precision engineered with high grade 400 series stainless steel bearings, fully sealed encased pinion gear system that is modular. A slewing bearing or slewing ring (also called a turntable bearing) is a rotational rolling-element bearing that typically supports a heavy but slow-turning or slowly oscillating loads in combination (axial, radial and moment loads), often a horizontal platform such as a conventional crane, a swing yarder, or the wind-facing platform of a horizontal-axis (yaw) windmill. In other orientations (e.g., a horizontal axis of rotation) they are used in materials handling grapples, forklift attachments, welding turnover jigs and so on.

Compared to a “normal” ball bearing the rings are quite wide and usually have holes drilled in them to provide fixation to a structure. Seals will be provided between the rings to protect the rolling elements. Compared to other rolling-element bearings, slewing bearings are relatively thin sections and require that the structure to which they are bolted is stiff enough so that under load predefined limits of distortion are not exceeded.

Slewing bearing designs range from single row ball or roller style, through double row ball or roller, triple row roller, combined (1 roller/ 1 ball) or wore guided raceways - each design having its own special characteristics and application. The Forza X1 design features precision engineered ceramic ball bearings which are designed to withstand the marine environment and are easily replaceable for teardown and rebuilds.

Cooling System

The cooling system consists of a raw water circuit that feeds up from the lower pod propeller unit and into a heat exchanger. The heat exchanger passes an internal glycol fluid over a series of interspersed tubes where heat conduction takes place to regulate the temperature of the glycol. The glycol is circulated through the gear reducer assembly, core motor and controller/inverter. The circuit uses a glycol pump mounted on or near the uni-body frame. The raw water exits from the heat exchanger and is released through a tube from the upper assembly.

59

Lower POD Propeller Assembly

The lower drive unit is a proprietary design that includes an advanced steering system, which allows up to 360 degrees of rotation of the propeller direction. This should result in boat owners realizing a higher level of vessel control when under speed as well as for docking and mooring maneuvers. Additionally, the unit is being designed with advanced safety features.

Furthermore, the lower drive unit is expected to include an easy interchange mechanism. This interchange mechanism will allow for different lower drive unit configurations to attach to a common upper motor assembly.

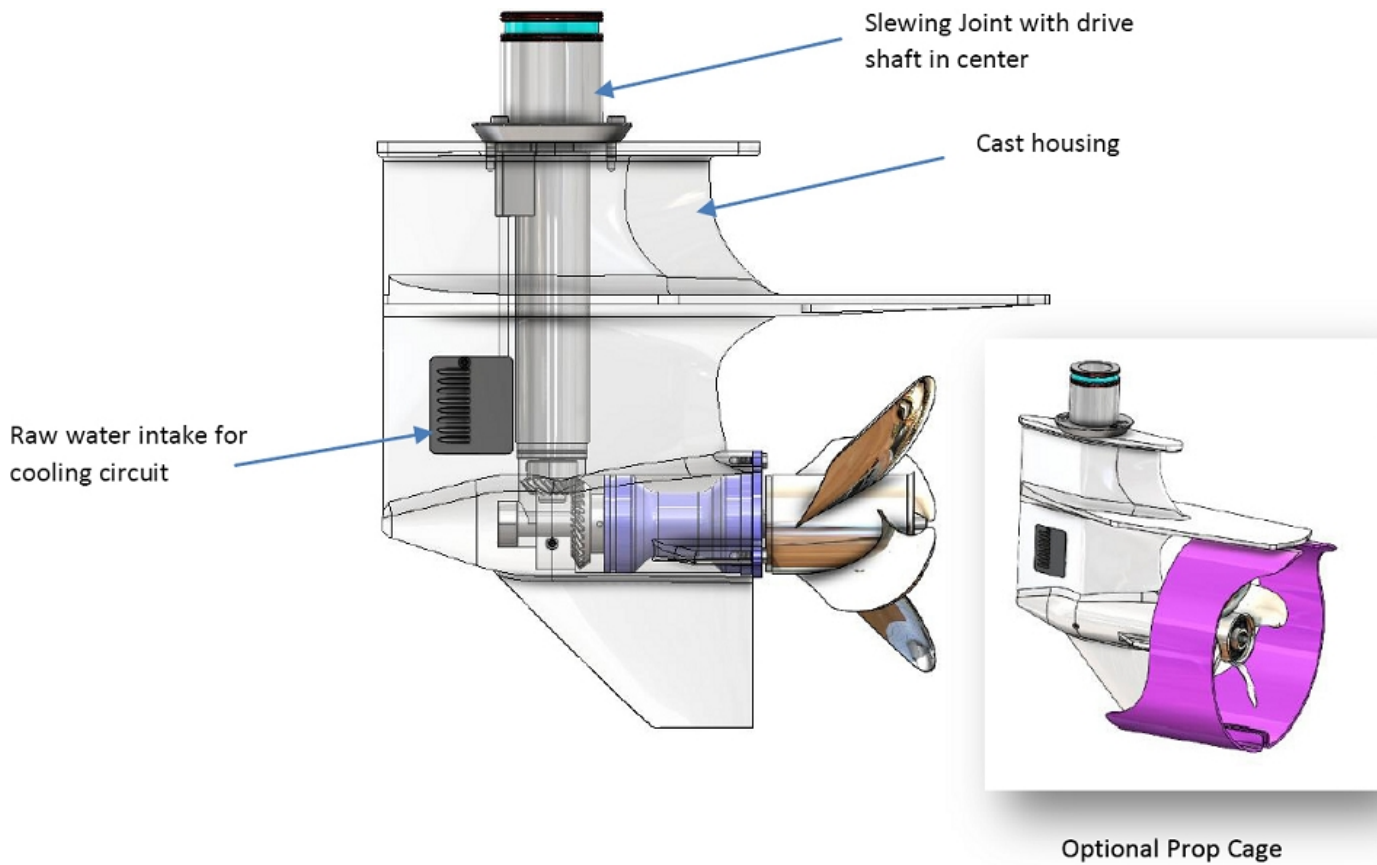

The propeller lower POD unit is expected to include a primary aluminum cast housing that is specifically engineered for electric propulsion. Because of the electric drive there is no need for the traditional reversing clutch mechanism or clutch actuation rod, or even the chambers for raw water exiting near the rear of the unit. This results in a lighter weight design with less parts and a more efficient drivetrain.

Forza X1 Battery Details

Nowadays, the most expensive part of an electric vehicle is the battery, which represents as much as 50% of the price of the electric propulsion system, depending on the technology used. Lithium-ion batteries are the most used technology in EVs due to their high energy density and increased power per mass battery unit.

The disadvantage of Lithium-ion batteries is their high developed operational temperature, which could affect energetic performances, along with lifetime expectations. This technology requires a battery management system (BMS) to control and monitor internal cell temperature. Apart from the disadvantages caused by exploitation temperature, there are also problems related to high production costs, recycling capacity of batteries out of use, and recharging infrastructure.

Our designers have the following general parameters in mind for the outboard battery system:

- 1) A module size of 36" x 12" x 4"
- 2) Mountable vertically or horizontally
- 3) Liquid cooling.
- 4) An IP rating of at least IP64, preferably IP65
- 5) Internal shock absorption.

Mounting of the battery packs is a crucial task especially for the 100kW battery range. These packs must be mounted with careful engineering for vibration isolation, cooling systems and ease of access in order to have the proper working and successful service procedures.

We have entered into a five- year supply agreement with a third-party lithium battery reseller to begin supplying us with a line-up of standardized high-voltage battery packs. The battery packs are highly flexible and modular that can be scaled in series or in parallel.

The battery packs are based on the world-class 2170 cylindrical cells and have the highest energy density solution in the market with approximately 200 Wh/kg, while also allowing advanced monitoring and diagnostic reporting. The packs contain a highly efficient, liquid cooled thermal management system and the sealed enclosures are rated IP65, which eliminates potential for debris and weather to get inside the battery pack.

Forza X1 Battery Characteristic	Unit	Specification*
Voltage, Nominal	V	352
Voltage, Range	V	270 - 403
Energy, Total	kWh	52
Capacity	Ah	150
Continuous Current	A	230

Peak Current (10 sec)	A	440
Volume	L	252
Mass	Kg	247
Energy Density	Wh/L	205
Specific Energy	Wh/kg	200
Dimensions (L x W x H)	mm	1,306 x 717 x 270
Operating Temperature	°C	-30 to 55

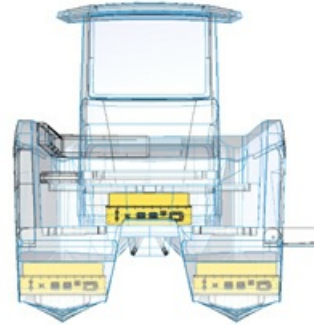

FORZA X1

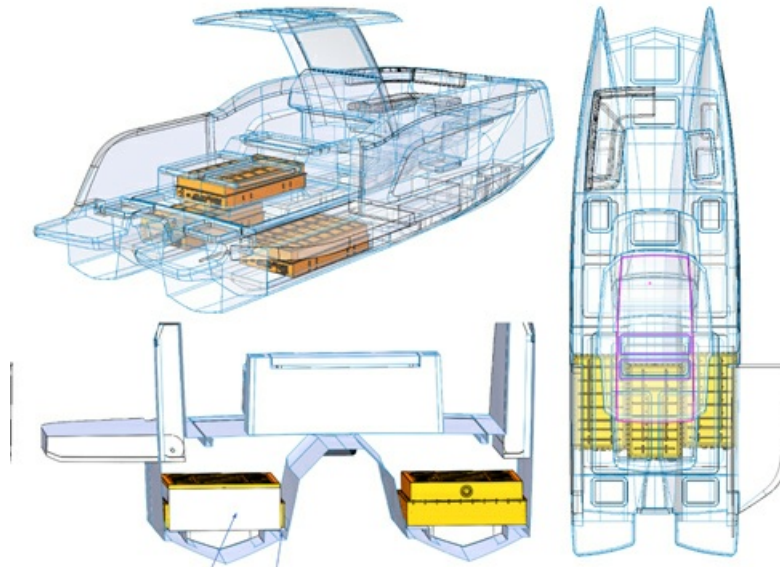

Onboard Battery Charging System

We intend to utilize multiple charging options that are currently available in the marketplace. The battery charging market has designed and commercially sold faster charging systems for years, but along with the increased speed of charging times, the cost of the equipment also goes up in price. We intend to offer an AC charging system that will be standard with the base boat. Additionally, we intend to offer a Direct Current or “DC” fast charging protocol as an option or as standard equipment on larger, higher priced boats. Specifically, we will adopt the most common connector plug for EV charging, the J1772, which was chosen by the Society of Automotive Engineers (SAE) as the standard in North America and Japan.

We will mostly utilize an alternating current (AC) charging current. Alternating current (AC) is typically how people charge their electric vehicles overnight. AC charging uses a lower voltage, either Level 1 (120 volts or normal household current) or Level 2 (240 volts or the equivalent power of an electric dryer). Though the low voltage levels mean a slower charge, AC charging can be easily installed in most households. It is a convenient solution for residential, workplace, multi-unit dwellings, and other longer-term parking locations like hotels and municipal or airport parking garages.

Direct current (DC) charging for electric vehicles allows for higher charging speeds, since DC can be supplied directly to the electric vehicle's battery at power levels normally higher than AC charging. The higher the DC power supplied, the faster the electric vehicle can be charged—provided the EV is designed to handle such power. Charging will slow down toward the end of each charging session in order to preserve the battery. This typically happens around 80% full.

The Combined Charging System (CCS) is a direct current (DC) fast charging protocol that is Society of Automotive Engineers (SAE) certified and is featured on vehicles produced by European and American car companies. The “combined” term in the CCS name designates its capability to incorporate the Level 2 (J1772 standard) plug and DC fast charging connector into the same larger plug.

The unit of energy to power an electric motor and charge a battery pack is based on the kWh or Kilo Watt Hour. A kWh unit of energy equivalent to the energy transferred or expended in one hour by one kilowatt of power. Electric car or boat battery sizes are measured in kilowatt-hours.

The FX1 boat may have the option for a 6.6 kW or 12 kW onboard charger compatible with Level 2 in-house charging. This means it can be charged at home from any outlet. When connected to a standard 120V 10A outlet, the charge rate is limited to 4 kW. Charge times are as shown below:

Power source	Charging Rate	DC Charging Current	Charge time
Fast Charge	45.0 kW	125A	1.8 hours
Inboard 50A	12.0 kW	33A	6.7 hours
Inboard 30A dryer outlet	6.6 kW	18A	12.1 hours
Standard 120 Outlet	4.0 kW	11A	20.0 hours



This assumes a standard 100 kWh pack discharged to 20 kWh with a 20% reserve.

FX1 Screen Integration

We are working to integrate a 22” screen into our FX1 console. The screen will be utilized for functionality including GPS mapping, depth finder, fish finder, speedometer, electronic compass, battery sensors, power rating, battery usage reporting, lighting controls, bilge and water pumps controls, autopilot and more. The screen would reduce traditional buttons that typically clutter a boat console and enhance a customer's boating experience. We are designing a customized graphical user interface at the helm to provide FX1 boat owners access to a suite of various systems, sonar technologies, autopilot, apps, engine data, and multimedia, all on one screen. Specifically, we plan to install a large-format multifunction display featuring a 22-inch full HD screen with touch control in Forza X1 boats. The sunlight-readable anti-glare large display should enable owners to experience a powerful, completely networked helm.

Our plans include a fully digital switching system that will allow users to power up their boat while away from the dock, switch on pumps, control lights, and underwater lights. Moreover, customers would be able to configure the entire system to provide 1-touch setting access for docking, cruising, fishing, and anchoring without manually switching each monitor separately.

Forza X1 Intellectual Property

We are working to create a portfolio of proprietary designs and technology that we expect to serve as the foundation of our product development. To date, we have three design and four utility patent applications on file with the United States Patent and Trademark Office. Certain of the patent applications were originally filed by, and in the name of, the individual who was the inventor of the technology and since have been assigned to us. Below is a list of pending patent applications that Forza X1 is seeking approval for from the United States Patent and Trademark Office. We cannot be certain that the patent applications that we file will issue, or that our issued patents will afford protection against competitors with similar technology. See “Intellectual Property Risks.”

IDEA / CONCEPT NAME	DESCRIPTION	IP TYPE	App Number and Filing Date
360 Steering Lower Pod with Disconnect	For outboard, lower pod steering mechanism using slewing bearing and spur gear mechanism allowing for a full 360 degree rotation. Also features a pass through the center method for cooling fluid, and an easy way to interchange lower drive units with the fixed upper unit.	Utility Patent Need to submit full application by March 2022	App # 63,207,748 FILING DATE 03/18/21
Original Outboard Cover Design	Original shape of outboard cover	Design Patent	App # 29/818,844 FILING DATE 12/10/21

Unibody Frame	Shape of frame that allows vertical mounting of motor and transmission inside the outboard	Design Patent	App # 29/818,842 FILING DATE 12/10/21
Outboard cover design - ALPHA 01 version	shape of the updated prototype cover and cowling	Design Patent	App # 29/819,262 FILING DATE 12/14/21
Trim and Tilt with cable routing thru pivot axis	A trim and tilt assembly that routes cables through the pivot axis which protects cables, keeps the bundle from excessive bending and results in a cleaner design	Utility Patent	App # 63,287,740 FILING DATE 12/09/21
Jet Drive Lower Unit for an Electric Outboard	The design of the lower jet drive as it is configured for the integration with the electric outboard	Utility Patent	App # 63,293,420 FILING DATE 12/23/21
Closed Loop Heat Exchanger Integrated in a Lower Drive Unit	Integrate a cooling radiator inside of the lower drive propeller or jet drive unit itself. Simplify the cooling circuit by eliminating the need for a raw sea water intake.	Utility Patent	App # 63,297,013 FILING DATE 1/06/22

Forza FX1 Future Factory

Forza XI is currently designing a state-of-the-art manufacturing plant to incorporate the latest in closed-molded composite boat building technologies and electric engine assembly processes. The target site for the plant is a parcel of land located in a light industrial corridor in St. Lucie County, where dozens of businesses, large and small, serve a vibrant and thriving marine manufacturing hub along the east central coast of Florida. The building is envisioned to be constructed totaling 100,000 square feet, capable of producing up to 1,000 engines and boat combination units. Multiple technologies are expected to be employed incrementally as volume and throughput needs increase, including 3D printing, robotic gel-coating and cutting, and ergonomically designed material handling equipment. Based on our current estimates, we project that the purchase and construction of the facility will cost approximately \$11,100,000, including \$750,000 for the purchase price of the parcel and the balance for site, building, and manufacturing needs. Specific requirements will include storm water drainage improvements, parking infrastructure, solar panel systems for net zero electricity consumption, specialized gel coat and fiberglass cutting booths, vacuum systems for closed molding infusion processes, CNC routers and cutters, and a dedicated machine shop and assembly area for electric engines, wire harnesses, and electronic propulsion systems. An engineering design and tooling center is planned to also be housed on-site to support new products and on-going technical improvements in electric engines, and electronic propulsion and control systems. This site will serve as a manufacturing center, administrative headquarters, and retail sales destination for our new customers.

The milestones related to our future factory that we have accomplished to date are as follows

- Real Estate contract execution date: 10/8/2021
- Phase I Environmental Assessment complete: 12/1/2021
- Due diligence expiration date: 12/8/2021
- Site plan and rezoning engineering and survey work executed: 1/07/2022

Our expected timetable for the milestones related to our future factory are as follows:

- Expected Planning and Zoning Board Hearing date: 3/17/2022
- Expected Site Plan Approval date: 4/19/2022
- Rezoning contingency expiration date: 5/06/2022
- Closing date for property: 5/18/2022
- Expected building steel order date: 6/15/2022
- Engineering Drawings for permits expected date: 7/30/2022
- Expected foundation permit date: 8/30/2022
- Site work and grading: 10/30/2022
- Building start: 12/1/2022
- Construction Complete: 8/1/2023

Before the completion of new factory construction, all fabrication for our Forza X1 boats will be performed onsite at Twin Vee's facility or, if needed, nearby manufacturing space will be leased. We expect that boat production can start immediately upon the Forza X1 product launch. We believe the Twin Vee site can handle approximately 100 units annually, without capital improvements, in addition to current Twin Vee production.

A phone app will be used to reserve orders, we expect it will be operational by June 2022 and believe we will be able to fulfill orders from Twin Vee as soon as the product launch is ready. The boat construction cycle (lead time) will be under fifteen working days, engines will be built in advance and will be a five-day build cycle. Since orders and deposits will be taken in advance of product launch, the fiberglass molds for the boats will be built to handle expected orders.

We expect production at the Forza FX1 future factory to initially ramp up according to orders received and increase over time.

Industry Overview

We believe traditional marine manufacturers are at a crossroads and face significant industry-wide challenges. Much like in the automotive industry, the reliance on the gasoline-powered internal combustion engine as the principal marine powertrain technology has raised environmental concerns, created dependence among industrialized and developing nations on oil-primarily imported from foreign countries, exposed consumers to volatile fuel prices, and inhibited innovation in alternative fuel powertrain technologies.

We expect that shifting consumer preferences will result in significant growth in the market for electric boats, especially as the demand for recreational powerboats, in general, remains strong. We estimate many consumers are increasingly willing to consider buying electric-powered boats due to the environmental and economic consequences of using gasoline-powered vehicles, as demonstrated by the increased sales of hybrid and electric automobiles in recent years. In its Electric Vehicle Outlook 2021, BloombergNEF estimated that there are currently 12 million passenger EVs on the road. The prevalence of electric-powered boats is likely to follow suit. In an August 2020 Boating Industry online article, the marine-focused magazine indicated that electric boat drives represented about 2% of the market, but hybrid and pure electric boats sales were expected to rise rapidly in the coming years. Specifically, the article cites a report from independent market research company IDTechEx where it examined the electric boat and ship sector. The report estimates that the market for hybrid and pure electric boats and ships would be greater than \$20 billion worldwide by 2027, finding that recreational boats is the largest and fastest growing electric marine market in sales number.

Our initiative into sustainable marine technologies and products is well-timed. The prevalence of batteries necessary to sustain a marine EV model line is expected to rise and become cheaper. BloombergNEF's Long-Term Electric Vehicle Outlook reports that annual lithium-battery demand has proliferated in recent years, and meeting the demand will require unprecedented but achievable increases in materials, components, and cell production. Battery production capacity is expanding as more factories are brought online. Moreover, battery technology that improves power and capacity is being designed, developed, and adopted regularly. According to BloombergNEF's report, it found that the volume-weighted average price of a lithium-ion battery pack fell 13% from 2019 to \$137/kWh (kilowatt-hour) in 2020. The report estimates the volume-weighted average cost of battery packs will drop below \$100/kWh in 2024. The Company is establishing itself in the market at the right time to help keep production costs as low as possible and make our boats affordable for our customers.

Our Solution

Our company believes our solid foundation in boat building, electric vehicle engineering expertise, and planned direct-to-consumer system will help us rapidly innovate and introduce new boats and technologies cost-effectively. By operating our sales and service network, we believe we can offer a compelling and premium customer-centric experience while achieving operating efficiencies and capturing sales and service revenues that traditional boat manufacturers do not receive in the independent dealer model. We also plan to leverage our electric powertrain technology to develop and sell powertrain components to other boat manufacturers and owners.

We believe our proprietary electric powertrain system will enable us to design and develop zero-emission boats that overcome the design, styling, and performance issues that have historically limited broad consumer adoption of electric boats. As a result, we believe customers of our vehicles will enjoy many benefits, including:

- **Extended Run Times and Recharging Flexibility.** We are designing our FX1 to offer an intermediate-range option and an option that would increase the battery pack capacity for extended run times. Charging stations specifically designed for electric boats will eventually be an option for customers as well. Norway and Venice, Italy, are beginning to construct a network of electric boat charging stations. In the United States, Lake Tahoe is now home to a rapid-charging electric boat charging station. While the US and the rest of the world begin to adopt a network of electric boat-specific stations, our design for the Forza X1 boats incorporates an onboard charging system, permitting recharging from almost any electrical outlet and residential and commercial charging stations previously only utilized for electric automobiles.
- **Energy Efficiency and Cost of Ownership.** We believe our FX1 will offer consumers an attractive cost of ownership compared to similar outboard powerboats. By using a single powertrain and customizing the systems within the electric powertrain and the rest of the boat, our boats are more energy-efficient, and therefore less expensive to operate and maintain.
- **Environmental sustainability.** Large gas-powered engines often leak and produce carbon emissions, both of which are generally harmful to fragile marine ecosystems. By offering a fully electric boat to our customers and an alternative to traditional propulsion systems, Forza X1 can foster a more environmentally sustainable boat brand. Our greatest hope is to be purposeful stewards of the marine industry and lead by example in environmentally friendly innovation.
- **Noise Level.** So often, powerboats create large amounts of noise, disturbing wildlife and making it difficult for fellow passengers to hear one another while underway. FX1's electric powertrain will produce little to no sound, making it easier to enjoy the sounds of nature, family, and friends. Forza X1 products will also help tremendously with fishing and other sporting and water-based activities that favor less noise.

Our Strengths and Competitive Advantages

We believe that the following are the critical investment attributes of our company:

- **Assembling a Technology, Engineering and Manufacturing Team.** We continue to build and add valuable, experienced and knowledgeable team members. Jim Leffew, our President, comes to us from Maverick Boat Group, Inc. that was recently sold to Malibu Boats. Jim Leffew has been designing, building and manufacturing boats on a large-scale basis for over 25 years. The year Maverick Boat Group was sold to Malibu Boats, Jim Leffew was overseeing the manufacturing and Maverick Boat Group was building and selling over 1,400 boats annually. The experience and knowledge that Jim Leffew brings to the table is expected to be valuable to the requirements of designing and ramping up our manufacturing facility.

- **Singular Focus and Leadership in Electric Powertrain Technology.** We intend to establish a first-mover advantage that would enable us to establish strong brand recognition and product/service loyalty before potential competing companies enter the market. Forza X1 is focused exclusively on developing our electric boats and electric powertrain technology to achieve a compelling combination of range and performance. We intend to use our electric powertrain expertise to innovate rapidly and sustain technological and time-to-market advantages over other marine manufacturers.
- **Combination of Expertise from the Traditional Boat Manufacturing Industry and Electrical Engineers** Our company's founders have been in the boat building business for over 25 years. Our boat design and manufacturing knowledge are supplemented by engineers with strong skills in electrical engineering and software and controls.
- **Rapid Customer-Focused Product Development.** We are designing our product development process to rapidly react to data collected from our boats, direct interaction with our customers, and feedback from our web and app platform. That information should enable us to introduce new models and features to expand our customer base and brand recognition.

- **Direct To Consumer System.** We are building a vertically integrated and premium direct-to-consumer system to achieve operating efficiencies and capture sales and service revenues traditional boat manufacturers do not generally receive in the distribution and service model they employ.
- **Capital Efficiency.** We believe our rapid product development process, powertrain technology applicable for future boat models, and our plan to hold lower inventory levels while still meeting customer demand will help reduce the capital required to reach operating efficiencies. This approach is designed to allow us to achieve profitability at relatively low sales volumes and create a viable long-term business.

Our Strategy

We intend to be a leading manufacturer and direct seller of electric boats and electric powertrain and propulsion technologies through the following strategies:

- **Successfully Launch the FX1.** We believe the successful launch of our first commercially available electric boat is critical to our ability to capitalize on the marine electric vehicle market opportunity and establish ourselves as leaders in the industry. We plan to complete the initial prototype boat by Q2 2022 and to commence commercial scale production in Q2 2023. We are currently executing a detailed plan to design, component source, engineer, and manufacture the FX1 and obtain the equipment to support its production.
- **Invest in Our Infrastructure.** We plan to invest in our product development and operations infrastructure to enable our growth, product innovation, and customer experience
- **Use a Common Platform to Introduce New Models.** We intend to design the FX1 with an adaptable platform architecture and common electric powertrain to provide us the flexibility to use the FX1 platform to launch subsequent electric boat models cost-efficiently.
- **Focus on Technological Advancements and Cost Improvement.** We intend to constantly look for ways to improve upon and further develop our proprietary electric powertrain system while reducing its manufacturing cost.
- **Build our Company-Owned Sales and Service Network.** Forza X1 is programming and building our expansive and vertically integrated customer-centric web and app platform to connect with customers for an end-to-end experience encompassing everything from buying, financing, delivery, servicing, and training. This customer-centric approach to sales and service is intended to simplify accessing necessary information for potential buyers and current owners in an easily accessible and streamlined online space.
- **Leverage Industry Advancements in Battery Cells.** We intend to leverage the substantial investments made globally by battery cell manufacturers to improve power and capacity.
- **Build and Leverage Strategic Relationships.** We intend to establish and develop strategic relationships with industry leaders to launch our planned electric boats and sell our electric boat powertrain components. We envision significant inroads with boat manufacturers to retrofit various hull configurations, replacing traditional gas outboard motors and existing boat owners who could retrofit their boats with Forza X1's outboard motors, controller, and battery packs.

Our Future Service Network

We intend to develop a support and service department that will include technicians, service representatives, quality control specialists and customer satisfaction agents. As we begin to sell and distribute boats, we will support and service the boats with our dedicated service and repair technicians. Based on the possible distance from our Fort Pierce factory to the location that the Forza boats will be delivered, for any customers located within 500 miles of our Fort Pierce factory we intend to add mobile service vans and trucks that will travel to the location of the electric boats for repair, or if the boat cannot be repaired at such location then the Forza technician will have a vehicle capable of towing the boat back to the Forza factory where the boat will have access to a larger amount of repair and support staff. We also intend to develop strategic relationships with boat repair service technicians in locations outside of Fort Pierce where our boats are sold. Our intention is to build a comprehensive service and support website and app that will permit Forza X1 customers to report through the Forza X1 app or directly with our service support team to schedule an appointment, perform remote diagnostics or help arrange for appointments with the technicians with whom we have strategic relationships. The website will be the cornerstone of our services and repair program. Customers will be able to access the website by phone or computer; however, we initially expect our customer base to be located in the major cities where we sell our boats. We are currently in the process of interviewing digital design web developers for the development of the app and expect to hire a digital design web developer after the consummation of this offering. Our goal is to have the app completed by no later than 14 months after the consummation of this offering.

We believe that our electric vehicles will require less service than gas vehicles because electric vehicles are simpler to maintain than internal combustion vehicles. Our outboard motor system is expected to be less susceptible to wear and tear by exchanging hundreds of moving parts for only a few. There are no spark plugs or engine motor oil to change or worry about. Whether a customer needs maintenance or needs repairs, we intend to provide convenient and comprehensive service coverage for our customers throughout the country.

Our goal is to build out a network of mobile service vehicles that will come to the customer when in person service or maintenance is required. For boats that need to visit a physical service location, we will pick up the boat and bring it in to one of our service locations. As part of our network, Forza X1 intends to develop a series of service relationships throughout the country at marinas or boat service centers where Forza X1 boats can be serviced and supported. Our mission will be to make the servicing of our products as simple as possible by connecting to and utilizing the diagnostics technology in every Forza X1 boat.

Remote diagnostics will allow the Company to find issues with customer boats remotely, in real time. In many cases, the Forza X1 service team will be able to provide an OTA update to resolve the issue without the customer's boat ever leaving the customer's sight. Whenever service needs require more than a mobile service visit or is outside the range of our mobile service van coverage, we will arrange for the boat to be picked up and brought to one of our partnered service centers. If a service center is not available in a particular area, then Forza X1 will permit the owners to take their boat to their local service center who will then invoice Forza X1 directly.

Competition

The performance sport boat category and the powerboat industry as a whole are highly competitive for consumers and dealers. We also compete against consumer demand for used boats. Competition affects our ability to succeed in both the markets we currently plan to serve and new markets that we may enter in the future. Competition is based primarily on brand name, price, product selection, and product performance. We will compete with several large manufacturers that may have greater financial, marketing, and other resources than we do and who are represented by dealers in the markets in which we now operate and into which we plan to expand. We also will compete with a variety of small, independent manufacturers. We cannot assure you that we will not face greater competition from existing large or small manufacturers or that we will be able to compete successfully with new competitors. Our failure to compete effectively with our current and future competitors would adversely affect our business, financial condition, and results of operations.

We also compete with other leisure activities. Our boats are not necessities and in times of economic hardship, consumers may cease purchasing non-essential items. Luxury items may not be used for recreational and sport purposes, and demand for our boats may be adversely affected by competition from other activities that occupy consumers' leisure time and by changes in consumer lifestyle, usage pattern or taste.

We also face competition for employees. Competition for individuals with experience designing, manufacturing and servicing electric boats is intense, and we may not be able to attract, assimilate, train or retain additional highly qualified personnel in the future. The failure to attract, integrate, train, motivate and retain these additional employees could seriously harm our business and prospects.

For more information, see “Risk Factors—Risks Related to Our Business—Our industry is characterized by intense competition, which affects our sales and profits” and “If we fail to manage future growth effectively, we may not be able to market or sell our products successfully.”

Environmental and Safety Matters

Certain materials used in our manufacturing, including the resins used in production of our boats, are toxic, flammable, corrosive or reactive and are classified by the federal and state governments as “hazardous materials.” Control of these substances is regulated by the Environmental Protection Agency, or EPA, and state pollution control agencies. The United States Clean Air Act (the “CAA”) and corresponding state and provincial rules regulate emissions of air pollutants. The Occupational Safety and Health Administration, or OSHA, standards limit the amount of emissions to which an employee may be exposed without the need for respiratory protection or upgraded plant ventilation. Twin Vee’s facilities are, and our future factory will be, regularly inspected by OSHA and by state and local inspection agencies and departments. We believe that our facility complies in all material aspects with these regulations. Although capital expenditures related to compliance with environmental laws are expected to increase, we do not currently anticipate any material expenditure will be required to continue to comply with existing environmental or safety regulations in connection with our existing manufacturing facilities.

Powerboats sold in the United States must be manufactured to meet the standards of certification required by the United States Coast Guard. In addition, boats manufactured for sale in the European Community must be certified to meet the European Community’s imported manufactured products standards. These certifications specify standards for the design and construction of powerboats. We believe that all of our boats will meet these standards. In addition, safety of recreational boats is subject to federal regulation under the Boat Safety Act of 1971, which requires boat manufacturers to recall products for replacement of parts or components that have demonstrated defects affecting safety. Twin Vee has instituted and we intend to institute recalls for defective component parts produced by certain of our third-party suppliers. None of Twin Vee’s recalls has had a material adverse effect on it.

If we are not able to pass these additional costs along to our customers, it may have a negative impact on our business and financial condition.

State Dealership and Servicing Regulations

Forza X1, Inc. intends to comply with specific state regulations, if any, regarding boat dealerships and servicing when it establishes its direct-to-consumer sales and service model. While there are limitations on the ability of a motor vehicle manufacturer to act as its own dealer to provide direct sales in many states, these limitations generally do not apply to boat manufacturers.

We will investigate each state’s laws before our products become available for purchase in that jurisdiction. To determine how the laws would apply to our business would require fact-specific analysis of numerous factors of business in the state, including whether we have a physical presence or employees, whether we advertise or conduct other marketing activities, how sale transactions are structured, the volume of sales into the state, and whether the state prohibits boat manufacturers from acting as dealers or servicing boats.

We plan to establish direct-to-consumer sales in those states where we are permitted to engage in direct-sales of our products. Moreover, in states where the law is unclear or prohibitive of direct sales, we intend to work with the governments of those states to carve out an exception for the sale of zero emission boats that are not available at other dealers within the state and, if necessary, seek to develop key dealers for the purpose of selling, delivering and servicing our boats within that particular state.

As a result, we may not be able to sell to customers in each state in the United States or provide service from a location in every state.

Employees/Human Capital

We believe we maintain excellent relations with our employees. As of February 3, 2022, we employed 3 people as full time employees, these employees are provided additional administrative support from Twin Vee We also work with a variety of third party consultants, including naval architects, electrical engineers, prototype professional and procurement professionals None of our employees are represented by a labor union.

Corporate Information

Our principal executive office is located at 3101 S. US-1, Ft. Pierce, Florida 34982, and our telephone number is 772-202-8039. We maintain our corporate website at www.forzax1.com. The information that can be accessed through our website is not part of this prospectus. Investors should not rely on any such information in deciding whether to purchase our common stock.

Forza X1, Inc. was initially incorporated as Electra Power Sports, Inc. on October 15, 2021, but we subsequently changed our name to Forza X1, Inc. on October 29, 2021. Our parent company was incorporated in the State of Florida as Twin Vee Catamarans, Inc. on December 1, 2009, and reincorporated in Delaware on April 7, 2021, as Twin Vee PowerCats Co.

Facilities

We currently share our corporate headquarters located at 3101 US Highway 1, Fort Pierce, Florida, 34982 with Twin Vee. Twin Vee’s parent company, Twin Vee PowerCats, Inc., leases the facility from Visconti Holdings, LLC, (“Visconti Holdings”) an entity owned and controlled by our Chairman, Chief Executive Officer and Director, Joseph Visconti pursuant to a lease agreement (the “Lease Agreement”), dated January 1, 2020, by and among the Company, Visconti Holdings, LLC and Twin Vee PowerCats, Inc. The Lease Agreement currently has a 5-year term, with an option to renew for an additional 5-year term. Our parent company currently pays Visconti Holdings \$26,500 per month plus applicable sales and use tax, which is currently 7% in St. Lucie County. While we believe these headquarters are adequate for our current operations and needs, we do believe, based upon indications of interest, that the capacity at the facility will not be sufficient to support both our full scale production and Twin Vee’s full scale production. Twin Vee entered into an agreement on our behalf that provides us with an option to acquire 14.5 acres of undeveloped land in Fort Pierce, Florida. On December 6, 2021, we paid the refundable deposit on the land purchase agreement. We are currently designing a state-of-the-art manufacturing plant to be built on the parcel as our future boat manufacturing facility. The parcel of land to be acquired and the manufacturing facility to be built on such property will be owned by us, and not Twin Vee. See “Forza FX1 Future Factory.”

Legal Proceedings

From time to time, we may become involved in litigation or other legal proceedings. We are not currently a party to any material litigation or legal proceedings. Regardless of outcome, litigation can have an adverse impact on us because of defense and settlement costs, diversion of management resources and other factors.

MANAGEMENT

Executive Officers and Directors

The following table sets forth the names, ages and positions of our executive officers and directors as of December , 2021:

Name	Age	Position
Executive Officers:		
Joseph C. Visconti	57	Chairman of the Board and Chief Executive Officer
Jim Leffew	58	President and Director
Carrie Gunnerson	46	Chief Financial Officer
Preston Yarborough	41	Director of Tooling and Director
Non-Employee Directors:		
Neil Ross (2)(3)(6)	60	Director
Bard Rockenbach(1)(3)	60	Director
Steven Shallcross(1)(2)(4)	59	Director
Kevin Schuyler (1)(2)(5)(6)	53	Director

- (1) Member of the audit committee
- (2) Member of the compensation committee
- (3) Member of the corporate governance and nominating committee
- (4) Chair of audit committee
- (5) Chair of compensation committee
- (6) Chair of corporate governance and nominating committee

Executive Officers

Joseph Visconti, Chairman of the Board and Chief Executive Officer

Mr. Visconti has been our Chairman of the Board and Chief Executive Officer since our inception (October 15, 2021) and the Chief Executive Officer, President and Director of Twin Vee Powercats Co., our parent company, since its inception (October 15, 2021). With over 25 years of executive level operational and financial experience, Mr. Visconti was the founder, CEO and President of two previous companies, the first company was a regional Investment Bank that he built to over 400 employees and sold in 2000. The second company was ValueRich, a financial media company that was taken public on the American Stock Exchange in 2007. ValueRich transitioned from media related business to Twin Vee PowerCats, Inc. in 2015. Mr. Visconti has experience building teams of professionals with a focus on product development and bringing those products to market. Mr. Visconti received his Associate's degree from Lynn University in 1984. We believe that Mr. Visconti's experience leading us and our parent company and his operational and financial experience makes him well qualified to be our Chairman of the Board and Chief Executive Officer.

Mr. Visconti currently devotes approximately 20% of his working time to our affairs.

Jim Leffew, President

Jim Leffew was appointed as our President in December 2021. Mr. Leffew served as the Senior Vice President, Manufacturing of Maverick Boat Group, Inc. from September 1999 until April 2021, where he was responsible for overseeing manufacturing operations and over 450 direct employees at a company with over \$125 million in sales. Prior to joining Maverick Boat Group, Inc., from September 1994 to September 1999 he was a Facilities Director at the Harbor Branch Oceanographic Institution where he directed all construction and maintenance needs for an over 500,000 square foot mixed-use space and managed a budget exceeding \$5 million a year. Mr. Leffew received his Bachelor of Science in Mechanical Engineering from the University of Central Florida in July 1987. Mr. Leffew's history and experience manufacturing products, budgeting and forecasting and managing direct employees will make him a valuable member of our management.

Carrie Gunnerson, Chief Financial Officer

Ms. Gunnerson has been our Chief Financial Officer since our inception (October 15, 2021) and the Chief Financial Officer of Twin Vee Powercats Co., our parent company, since October 2021. Ms. Gunnerson served as the President and Chief Executive Officer of Art's Way Manufacturing Co., Inc. ("Art's Way") from October 18, 2007 until July 21, 2020, as its Chief Financial Officer from July 2004 until January 2012 and interim from September 2012 until January 22, 2015 and again from May 31, 2018 until February 1, 2020. Prior to joining Art's Way in 2004, from 2001 until 2004 Ms. Gunnerson was employed by Tyco Plastics Inc., where she was responsible for all of the functions of a controller. Ms. Gunnerson was named a director of the Farm Equipment Manufacturers Association, effective in November 2016.

Ms. Gunnerson currently devotes approximately 20% of her working time to our affairs.

Preston Yarborough, Director of Tooling and Director

Preston Yarborough is the Director of Tooling and holds a seat on the Board. He brings over 23 years of marine manufacturing experience to our team. In addition to his positions of Vice President and Director of Product Development of Twin Vee PowerCats Co., he holds a seat on the Board of Directors of that company as well. For the last several years, Mr. Yarborough has led the design, development and production of Twin Vee PowerCats Co.'s models and built over 8,000 boats in his tenure. His innovative, forward thinking coupled with his eye for quality production has been key in positioning Twin Vee as an industry leader in powercat design.

In addition to Twin Vee's core line of boats, Mr. Yarborough has designed and produced specialized vessels for the US Navy, the National Park Service, various state agencies such as the Florida Fish and Wildlife Conservation Commission and the Florida Department of Environmental Protection, multiple county and local governments, along with numerous universities and private research organizations. Additionally, SeaWorld Parks and Entertainment, Georgia Aquarium, Discovery Channel, several motion picture companies and many other companies have purchased Twin Vee boats which were all designed by Mr. Yarborough to fit their specific needs.

Mr. Yarborough has received his Composite Tech Certification with ACMA as is a Certified Outboard Suzuki Marine Tech.

Mr. Yarborough currently devotes approximately 20% of his working time to our affairs.

Independent Directors

Kevin Schuyler, CFA, Director

Kevin Schuyler has been a member of our Board of Directors since December 2021. Mr. Schuyler is the Vice Chairman of the board of directors and Lead Independent Director of Adial Pharmaceuticals, Inc. (NASDAQ: ADIL) where he has served as a director since April 2016. He currently also serves as a senior managing director at CornerStone Partners, a full-service institutional CIO and investment office located in Charlottesville, VA, with approximately \$10 billion under management. Prior to joining CornerStone Partners in 2006, he held various positions with McKinsey & Company, Louis Dreyfus Corporation and The Nature Conservancy. Mr. Schuyler serves on various boards and committees of Sentara Martha Jefferson Hospital, the US Endowment for Forestry and Communities, and Stone Barns Center. He is a member of the investment committee of the Margaret A. Cargill Philanthropies. Mr. Schuyler graduated with honors from Harvard College and received his MBA from The Darden Graduate School of Business at the University of Virginia. He is a member of the Chartered Financial Analyst Society of Washington, DC.

We selected Mr. Schuyler to serve on our board of directors because he brings extensive knowledge of the financial markets. Mr. Schuyler's business background provides him with a broad understanding of the financial markets and the financing opportunities available to us.

70

Neil Ross, Director

Mr. Ross has been a member of our Board of Directors since December 2021 and a member of the Board of Directors of Twin Vee Powercats Co., our parent company, since April 2021. He has over 30 years of experience in launching products and companies and promoting and growing brands. He has served as the Chief Executive Officer of James Ross Advertising since founding it in February 2003. Most notably, Neil has extensive marine experience partnering with brands like Galati Yachts Sales, Jefferson Beach Yacht Sales, Allied Marine, Bertram Yachts, Twin Vee, Jupiter Marine and Sealine to name a few. Mr. Ross received his Bachelor's degree from Florida State University. We believe Mr. Ross' experience in the yacht and boating industry as well as his expertise in brand awareness and growth makes him well qualified to be a director of the Company.

Bard Rockenbach, Director

Mr. Rockenbach has been a member of our Board of Directors since December 2021 and a member of the Board of Directors of Twin Vee Powercats Co., our parent company, since April 2021. Mr. Rockenbach career spans over 31 years in the legal industry. Since January 2005, he has been the managing partner of Burlington & Rockenbach, P.A., a trial and appellate litigation law firm based in West Palm Beach, Florida. He is Board Certified by the Florida Bar Association in Appellate Practice and has served an expert witness in various legal proceedings. Mr. Rockenbach holds a Juris Doctor from Stetson University College of Law where he graduated in 1988 20th in his class. We believe Mr. Rockenbach legal and business experience makes him well qualified to be a director of the Company.

Steven Shallcross, Director

Mr. Shallcross has been a member of our Board of Directors since December 2021 and a member of the Board of Directors of Twin Vee Powercats Co., our parent company, since April 2021. Mr. Shallcross has also served as a Board member of Elys Game Technologies, Corp. (NASDAQ: ELYS) an international, vertically integrated commercial-stage company engaged in various aspects of the leisure gaming industry since June 13, 2019, and Synthetic Biologics Inc. (NYSE American: SYN) ("Synthetic Biologics") since December 6, 2018 and as its Chief Executive Officer, a position he was appointed to on December 6, 2018 where he currently serves as Chief Financial Officer. Mr. Shallcross was appointed as the Interim Chief Executive Officer of Synthetic Biologics on December 5, 2017 and has served as its Chief Financial Officer, Treasurer and Secretary since June 2015. From May 2013 through May 2015, Mr. Shallcross served as Executive Vice President and Chief Financial Officer of Nuo Therapeutics, Inc. (formerly Cytomedix, Inc.). In January 2016, Nuo Therapeutics, Inc. filed a voluntary petition for relief under Chapter 11 of the U.S. Bankruptcy Code in the United States Bankruptcy Court for the District of Delaware and on April 25, 2016, the Bankruptcy Court entered an order granting approval of Nuo's plan of reorganization. From July 2012 to May 2013, Mr. Shallcross held the offices of Executive Vice President, Chief Financial Officer and Treasurer of Empire Petroleum Partners, LLC, a motor fuel distribution company. From July 2011 to March 2012, Mr. Shallcross was Acting Chief Financial Officer of Senseonics, a privately held medical device company located in Germantown, MD. From January 2009 to March 2011, he served as Executive Vice President and Chief Financial Officer of Innocoll AG (formerly privately held Innocoll Holdings, Inc.), a global, commercial-stage biopharmaceutical company specializing in the development and commercialization of collagen-based products. He also served for four years as the Chief Financial Officer and Treasurer of Vanda Pharmaceuticals, Inc., leading the company through its successful IPO and follow-on offering and previously served as the Senior Vice President and Chief Financial Officer of Middlebrook Pharmaceuticals, Inc. (formerly Advancis Pharmaceutical Corporation). In addition, Mr. Shallcross also served as the Chief Financial Officer of Bering Truck Corporation. He holds an MBA from the University of Chicago's Booth School of Business, a Bachelor of Science degree in Accounting from the University of Illinois, Chicago, and is a Certified Public Accountant in the State of Illinois. We believe that Mr. Shallcross' operational, financial and international experience, as well as an established track record at leading the financial development and strategy for several publicly traded companies, makes him well qualified to be a director of the Company.

The FX1 Engineering and Technical Team

Daniel Norton, Director of Engineering.

Mr. Norton has spent over 20 years working in the technical design engineering arena for companies including Caterpillar Inc., Gerber Technology, and ATI Industrial Automation, in various project management and engineering development positions. He currently holds over 20 patents related to innovative electromechanical solutions to automation, boat docking, and work piece clamping. He is also the inventor of the NLS (Nautical Landing System) technology and has been developing the Smartlander positive restraint system for use in heavy duty marine applications. Mr. Norton received his Bachelor of Science degree in Mechanical Engineering in 1998, from Northeastern University. and is a member of the American Society of Mechanical Engineers. He received his Certified Scrum Product Owner certification in 2019.

71

Jean-Marc Zanni, Chief Technology Officer.

Mr. Zanni specializes in integrating solutions for marine and industrial automation projects focusing on fluid dynamics and marine engineering. Mr. Zanni has more than 20 years of industrial high-voltage electrical system practical experience developing and implementing proprietary software control technology used to optimize electrical energy management and battery chemistry. Mr. Zanni has served from June 2015 to December 2021 as the President of AE&M Engineering, a company he founded, designing clean hybrid energy solutions for specialty markets. Prior to founding AE&M Engineering, from October 2010 to May 2015, Mr. Zanni served as the Director of Engineering ReGen Nautic USA. In this capacity he served as a proxy member for the American Boating & Yachting Counsel (ABYC) Committee for Electric Propulsion. Mr. Zanni received his Engineering Master's degree at E.N.S. des Arts et Métiers (ParisTech) in June 1983.

Chandan R. Chittimalle, Chief Electrical Engineer.

Mr. Chittimalle served as Senior Controls Engineer of Thrustmaster of Texas, Inc. from August 2019 to November 2021 designing and developing battery charging control systems and battery cooling systems. From August 2015 to August 2019, he served as an Electrical Design Engineer III, and from August 2012 to August 2015, her served as an Electrical Intern/ Electrical Design Engineer, at Thrustmaster of Texas, Inc. Mr. Chittimalle received his Master of Science, Engineering from California State University in

Family Relationships

No family relationships exist between any director, executive officer or person nominated or chosen to be a director or officer.

Board of Directors Composition

Our board of directors currently consists of seven members. Each of our current directors will continue to serve as a director until the election and qualification of his or her successor, or until his or her earlier death, resignation or removal.

Our certificate of incorporation provides that our board of directors is divided into three classes with staggered three-year terms. Only one class of directors will be elected at each annual meeting of stockholders, with the other classes continuing for the remainder of their respective three-year terms. Our current directors are divided among the three classes as follows:

- the Class I directors are Jim Leffew and Kevin Schuyler, and their terms will expire at the annual meeting of stockholders to be held in 2022;
- the Class II directors are Bard Rockenbach and Preston Yarborough, and their terms will expire at the annual meeting of stockholders to be held in 2023; and
- the Class III directors are Steven Shallcross, Neil Ross and Joseph Visconti, and their terms will expire at the annual meeting of stockholders to be held in 2024.

At each annual meeting of stockholders, upon the expiration of the term of a class of directors, the successor to each such director in the class will be elected to serve from the time of election and qualification until the third annual meeting following his or her election and until his or her successor is duly elected and qualified, in accordance with our certificate of incorporation. Any additional directorships resulting from an increase in the number of directors will be distributed among the three classes so that, as nearly as possible, each class will consist of one-third of our directors.

This classification of our board of directors may have the effect of delaying or preventing changes in control of our company.

In addition, under the terms of our certificate of incorporation and our bylaws, members of our board of directors may only be removed for cause. This may also have the effect of delaying or preventing changes in control of our company.

Director Independence

We intend to apply for our common stock to be listed on the Nasdaq Capital Market, or Nasdaq. Under the rules of Nasdaq, independent directors must comprise a majority of a listed company's board of directors within one year of the completion of its initial public offering. In addition, the rules of Nasdaq require that, subject to specified exceptions, each member of a listed company's audit, compensation and corporate governance and nominating committees be independent. Audit committee members and compensation committee members must also satisfy the independence criteria set forth in Rule 10A-3 and Rule 10C-1, respectively, under the Exchange Act. Under the rules of Nasdaq, a director will only qualify as an "independent director" if, in the opinion of that company's board of directors, that person does not have a relationship that would interfere with the exercise of independent judgment in carrying out the responsibilities of a director.

To be considered to be independent for purposes of Rule 10A-3 and under the rules of Nasdaq, a member of an audit committee of a listed company may not, other than in his or her capacity as a member of the audit committee, the board of directors, or any other board of directors committee: (1) accept, directly or indirectly, any consulting, advisory, or other compensatory fee from the listed company or any of its subsidiaries; or (2) be an affiliated person of the listed company or any of its subsidiaries.

To be considered independent for purposes of Rule 10C-1 and under the rules of Nasdaq, the board of directors must affirmatively determine that each member of the compensation committee is independent, including a consideration of all factors specifically relevant to determining whether the director has a relationship to the company which is material to that director's ability to be independent from management in connection with the duties of a compensation committee member, including, but not limited to: (i) the source of compensation of such director, including any consulting, advisory or other compensatory fee paid by the company to such director; and (ii) whether such director is affiliated with the company, a subsidiary of the company or an affiliate of a subsidiary of the company.

Our board of directors undertook a review of its composition, the composition of its committees and the independence of our directors and considered whether any director has a material relationship with us that could compromise his or her ability to exercise independent judgment in carrying out his or her responsibilities. Based upon information requested from and provided by each non-employee director concerning his or her background, employment and affiliations, including family relationships, our board of directors has determined that none of Messrs. Ross, Rockenbach, Schuyler and Shallcross have relationships that would interfere with the exercise of independent judgment in carrying out the responsibilities of a director and that each of these directors is "independent" as that term is defined under the rules of Nasdaq and Rule 10A-3 and Rule 10C-1 under the Exchange Act.

In making these determinations, our board of directors considered the current and prior relationships that each non-employee director has with our company and all other facts and circumstances our board of directors deemed relevant in determining their independence, including the beneficial ownership of our capital stock by each non-employee director, and the transactions involving them described in the section titled "Certain Relationships and Related Party Transactions."

Board of Directors Leadership Structure

Our Chief Executive Officer serves as our Chairman of the Board. Our Board does not have a lead independent director. Our Board has determined its leadership structure is appropriate and effective given our stage of development.

Board of Directors Committees

Upon completion of this offering our board of directors will have an audit committee, a compensation committee and a corporate governance and nominating committee, each of which will have the composition and the responsibilities described below.

Audit Committee

Upon completion of this offering the members of our audit committee will consist of Bard Rockenbach, Kevin Schuyler and Steven Shallcross. Mr. Shallcross will be the chair of our audit committee. All of the members of the audit committee will be independent, as that term is defined under the rules of Nasdaq. The primary purpose of the audit

committee is to oversee the quality and integrity of our accounting and financial reporting processes and the audit of our financial statements. Specifically, the audit committee will:

- select and hire the independent registered public accounting firm to audit our financial statements;
- help to ensure the independence and performance of the independent registered public accounting firm;
- approve audit and non-audit services and fees;
- review financial statements and discuss with management and the independent registered public accounting firm our annual audited and quarterly financial statements, the results of the independent audit and the quarterly reviews and the reports and certifications regarding internal controls over financial reporting and disclosure controls;
- prepare the audit committee report that the SEC requires to be included in our annual proxy statement;
- review reports and communications from the independent registered public accounting firm;
- review the adequacy and effectiveness of our internal controls and disclosure controls and procedure;
- review our policies on risk assessment and risk management;
- review related party transactions; and
- establish and oversee procedures for the receipt, retention and treatment of accounting related complaints and the confidential submission by our employees of concerns regarding questionable accounting or auditing matters.

Our audit committee will operate under a written charter, to be effective prior to the completion of this offering, which will satisfy the applicable rules of the SEC and the listing standards of Nasdaq.

Our board of directors has determined that Mr. Shallcross is an “audit committee financial expert” as defined in applicable SEC rules.

Compensation Committee

Upon completion of this offering the members of our compensation committee will consist of Kevin Schuyler, Neil Ross and Steven Shallcross. Mr. Schuyler will be the chair of our compensation committee. All of the members of our compensation committee will be independent, as that term is defined under the rules of Nasdaq. Our compensation committee oversees our compensation policies, plans and benefits programs. The compensation committee will also:

- oversee our overall compensation philosophy and compensation policies, plans and benefit programs;
- review and recommend to our board of directors for approval compensation for our executive officers and directors;
- prepare the compensation committee report that the SEC would require to be included in our annual proxy statement if we were no longer deemed to be an emerging growth company or a smaller reporting company; and
- administer our equity compensation plans.

Our compensation committee will operate under a written charter, to be effective prior to the completion of this offering, which will satisfy the applicable rules of the SEC and the listing standards of Nasdaq.

Corporate Governance and Nominating Committee

Upon completion of this offering the members of our corporate governance and nominating committee will consist of Neil Ross and Bard Rockenbach. Mr. Schuyler will be the chair of our corporate governance and nominating committee. All will be independent, as that term is defined under the rules of Nasdaq. Our corporate governance and nominating committee oversees and assists our board of directors in reviewing and recommending nominees for election as directors. Specifically, the corporate governance and nominating committee will:

74

- identify, evaluate and make recommendations to our board of directors regarding nominees for election to our board of directors and its committees;
- consider and make recommendations to our board of directors regarding the composition of our board of directors and its committees;
- review developments in corporate governance practices;
- evaluate the adequacy of our corporate governance practices and reporting; and
- evaluate the performance of our board of directors and of individual directors.

Our corporate governance and nominating committee will operate under a written charter, to be effective prior to the completion of this offering, which will satisfy the applicable rules of the SEC and the listing standards of Nasdaq.

Director Compensation

To date, our directors have not received any compensation for their service as directors. Commencing after this offering, directors who are not employees will receive compensation for their service as directors, including service as members of each committee on which they serve.

Cash Compensation

All non-employee directors will be entitled to receive the following cash compensation for their services following the effective date of the registration statement of which this prospectus forms a part:

- \$10,000 per year for service as a board member;
- \$20,000 per year additionally for service as chair of the audit committee;

- \$7,500 per year additionally for service as member of the audit committee (excluding committee chair);
- \$15,000 per year additionally for service as chair of the compensation committee;
- \$5,000 per year additionally for service as member of the compensation committee (excluding committee chair);
- \$7,500 per year additionally for service as chair of the corporate governance and nominating committee;
- \$3,000 per year additionally for service as member of the corporate governance and nominating committee (excluding committee chair);

All cash payments to non-employee directors who served in the relevant capacity at any point during the immediately preceding prior fiscal quarter will be paid quarterly in arrears. A non-employee director who served in the relevant capacity during only a portion of the prior fiscal quarter will receive a pro-rated payment of the quarterly payment of the applicable cash retainer.

Equity Compensation

Effective upon the closing of this offering, each non-employee director will receive an initial grant of non-qualified stock options under our 2022 Plan to purchase 5,500 shares of our common stock, which options will vest *pro rata* on a monthly basis over a period of twelve months from the grant date, subject to the grantee's continued service through that date. We intend to make annual equity grants to non-employee directors coincident with each annual meeting of stockholders.

Compensation Committee Interlocks and Inside Participation

None of the members of our compensation committee are or have been an officer or employee of our company. None of our executive officers currently serve, or in the past fiscal year has served, on the board of directors or compensation committee (or other board of directors' committee performing equivalent functions) of any entity that has one or more executive officers serving on such board of directors or compensation committee, other than our parent company.

Risk Oversight

In its governance role, and particularly in exercising its duty of care and diligence, the board of directors is responsible for ensuring that appropriate risk management policies and procedures are in place to protect the company's assets and business. Our board of directors has broad and ultimate oversight responsibility for our risk management processes and programs and executive management is responsible for the day-to-day evaluation and management of risks to our company.

Code of Business Conduct and Ethics

We have adopted a written code of business conduct and ethics that applies to our directors, officers and employees, including our principal executive officer, principal financial officer, principal accounting officer or controller, or persons performing similar functions. Following the completion of this offering, the code of business conduct and ethics will be available on our website at www.forzax1.com. We intend to disclose future amendments to such code, or any waivers of its requirements, applicable to any principal executive officer, principal financial officer, principal accounting officer or controller or persons performing similar functions or our directors on our website identified above. The inclusion of our website address in this prospectus does not include or incorporate by reference the information on our website into this prospectus. We will provide any person, without charge, upon request, a copy of our code of conduct and ethics. Such requests should be made in writing to the attention of Glenn Sonoda, Secretary, Forza X1, Inc., 3101 US-1 Fort Pierce, Florida 34982.

Limitation of Liability and Indemnification

Our certificate of incorporation and bylaws provides that we will indemnify our directors and officers, and may indemnify our employees and other agents, to the fullest extent permitted by Delaware law. Delaware law prohibits our certificate of incorporation from limiting the liability of our directors for the following:

- any breach of the director's duty of loyalty to us or to our stockholders;
- acts or omissions not in good faith or that involve intentional misconduct or a knowing violation of law;
- unlawful payment of dividends or unlawful stock repurchases or redemptions; and
- any transaction from which the director derived an improper personal benefit.

If Delaware law is amended to authorize corporate action further eliminating or limiting the personal liability of a director, then the liability of our directors will be eliminated or limited to the fullest extent permitted by Delaware law, as so amended. Our certificate of incorporation does not eliminate a director's duty of care and, in appropriate circumstances, equitable remedies, such as injunctive or other forms of non-monetary relief, remain available under Delaware law. This provision also does not affect a director's responsibilities under any other laws, such as the federal securities laws or other state or federal laws. Under our bylaws, we will also be empowered to purchase insurance on behalf of any person whom we are required or permitted to indemnify.

In the case of an action or proceeding by or in the right of our company or any of our subsidiaries, no indemnification will be provided for any claim where a court determines that the indemnified party is prohibited from receiving indemnification. We believe that these charter and bylaw provisions are necessary to attract and retain qualified persons as directors and officers.

The limitation of liability and indemnification provisions in our certificate of incorporation and bylaws may discourage stockholders from bringing a lawsuit against directors for breach of their fiduciary duties. They may also reduce the likelihood of derivative litigation against directors and officers, even though an action, if successful, might benefit us and our stockholders. Moreover, a stockholder's investment may be harmed to the extent we pay the costs of settlement and damage awards against directors and officers pursuant to these indemnification provisions.

Insofar as indemnification for liabilities arising under the Securities Act may be permitted to our directors, officers and controlling persons pursuant to the foregoing provisions, or otherwise, we have been advised that, in the opinion of the SEC, such indemnification is against public policy as expressed in the Securities Act, and is, therefore, unenforceable. There is no pending litigation or proceeding naming any of our directors or officers as to which indemnification is being sought, nor are we aware of any pending or threatened litigation that may result in claims for indemnification by any director or officer.

We intend to enter, into separate indemnification agreements with each of our directors and executive officers, in addition to the indemnification that will be provided for in our certificate of incorporation and bylaws. The indemnification agreements and our amended restated certificate of incorporation and bylaws that will be in effect upon the

EXECUTIVE COMPENSATION

Our named executive officers for 2021 which consisted of our principal executive officer and the next most highly compensated executive officer, were:

- Joseph C. Visconti, Chairman and Chief Executive Officer
- Jim Leffew, President
- Carrie Gunnerson, Chief Financial Officer
- Preston Yarborough, Director of Tooling

Summary Compensation Table

The following table sets forth information regarding the compensation that was paid to our named executive officers during the year ended December 31, 2021

Name and Principal Position	Year	Salary (\$)	Bonus (\$)	Option Awards (\$)(1)	All Other Compensation (\$)	Total (\$)
Joseph C. Visconti ⁽¹⁾	2021					
Chief Executive Officer	2020					
Jim Leffew ⁽²⁾	2021	4,808				
President	2020					
Carrie Gunnerson ⁽¹⁾	2021					
Chief Financial Officer	2020					
Preston Yarborough Director of Tooling ⁽¹⁾	2021					

(1) During the year ended December 31, 2021, we did not pay any compensation for services rendered by Messrs. Visconti and Yarborough or Ms. Gunnerson; however, Messrs. Visconti and Yarborough and Ms. Gunnerson each receive compensation from Twin Vee for services performed for us and for Twin Vee.

(2) Mr. Leffew was appointed our President on December 15, 2021.

Outstanding Equity Awards at Fiscal Year-End

As of December 31, 2021, we had not issued any equity awards to any of our named executive directors.

Officer and Director Compensation

Other than Jim Leffew, none of our officers or directors has received any cash compensation for services rendered to us. However, Mr. Visconti, Ms. Gunnerson and Mr. Yarborough each have employment agreements with Twin Vee and received compensation from Twin Vee during 2021. In consideration of Twin Vee providing the services of Mr. Visconti, Ms. Gunnerson and Mr. Yarborough to us, we recorded management fees of \$15,000 paid to Twin Vee during the period of inception (October 15, 2021) through December 31, 2021, pursuant to a management agreement with it for various management services. The management agreement provides for a monthly \$5,000 management fee, has a term of one year and will expire on September 30, 2022. It is anticipated that following the completion of this offering we will transition the management agreement with Twin Vee from an agreement providing management services to an administrative services agreement under which Twin Vee would provide us with certain administrative services, such as procurement, shipping, receiving, storage and use of Twin Vee’s facility until our new planned facility is completed, and that we will enter into separate employment agreements with Mr. Visconti, Ms. Gunnerson and Mr. Yarborough to compensate them directly for the services provided to us based on the relative time spent on our matters and Twin Vee matters.

Outstanding Equity Awards at Fiscal Year-End

As of December 31, 2021, we had not issued any equity awards to any of our named executive directors.

Employment Arrangements with Our Named Executive Officers

Other than the employment agreement with Jim Leffew, we do not have written employment agreements with any of our executive officers.

Jim Leffew

Employment Agreement

We have entered into a three-year employment agreement with Mr. Leffew (the “Leffew Employment Agreement”) effective as of December 15, 2021 (the “Effective Date”). Under the Leffew Employment Agreement, Mr. Leffew serves as our President. He receives an annual base salary of \$125,000 and is eligible to receive an annual performance cash bonus with a target amount equal to 100% of his annual base salary, based upon achievement of performance goals established by the compensation committee of the board of directors. In addition, upon the completion of this offering, Mr. Leffew’s annual base salary will be increased to \$250,000 and he will be granted a stock option to purchase 400,000 shares of our common stock under our proposed 2022 Stock Option Plan, which will vest *pro rata* on a monthly basis over a three-year period subject to continued employment through each vesting date.

The Leffew Employment Agreement provides that Mr. Leffew will be eligible to participate in all benefit and fringe benefit plans generally made available to our other executive officers. In addition, he is entitled to four weeks of paid vacation per year.

The Leffew Employment Agreement provides that it shall continue until terminated (i) by mutual agreement; (ii) due to death or disability of Mr. Leffew; (iii) by Mr. Leffew without good reason upon 90 days written notice to us; (iv) by us for cause (as defined in the Leffew Employment Agreement); (v) by us without cause; or (vi) by Mr. Leffew for good reason (as defined in the Leffew Employment Agreement).

Pursuant to the Leffew Employment Agreement, Mr. Leffew is subject to a one-year post-termination non-compete and non-solicit of employees and clients. He is also bound by confidentiality provisions.

In the event of a termination by us without cause or a termination by Mr. Leffew for good reason during the first six months following the Effective Date, he will receive a severance payment equal to his monthly base salary as is in effect on the termination date multiplied by three (less applicable tax withholdings), such amounts to be paid out monthly in substantially equal installments over the three month period following such termination in accordance with our normal payroll policies. If Mr. Leffew's employment is terminated by us without cause or if he resigns for Good Reason after the first six months following the Effective Date, he will receive a severance payment equal to his monthly base salary as is in effect on the termination date multiplied by six (less applicable tax withholdings), such amounts to be paid out monthly in substantially equal installments over the six month period following such termination in accordance with the Company's normal payroll policies.

The receipt of any termination benefits described above is subject to Mr. Leffew's execution of a release of claims in favor of the Company, a form of which is attached as an exhibit to the Leffew Employment Agreement.

In the event of Mr. Leffew's termination due to death or disability, Mr. Leffew will receive full vesting for any outstanding, unvested equity awards granted under the 2022 Plan. Mr. Leffew's outstanding vested stock options will generally remain exercisable no longer than six months following such a termination.

Employment Arrangements with Twin Vee

As described below, Mr. Visconti, Ms. Gunnerson and Mr. Yarborough each have employment agreements with Twin Vee pursuant to which they provide services to us as an extension of their responsibilities at Twin Vee pursuant to the management agreement between us and Twin Vee. As such, they are bound by the same duty of care and effort to Forza X1 as they are to Twin Vee.

Joseph Visconti

Employment Agreement

Twin Vee entered into a five-year employment agreement with Mr. Visconti (the "Visconti Employment Agreement") effective upon its initial public offering in July 2021. Under the Visconti Employment Agreement, Mr. Visconti serves as Twin Vee's President and Chief Executive Officer. He receives an annual base salary of \$250,000 and is eligible to receive an annual performance cash bonus with a target amount equal to 100% of his annual base salary, based upon achievement of performance goals established by the compensation committee of Twin Vee's board of directors. Upon the completion of Twin Vee's offering in July 2021, Mr. Visconti received a stock option to purchase 272,000 shares of Twin Vee's common stock under its 2021 Plan, vesting pro rata on a monthly basis over a three-year period subject to continued employment through each vesting date. In addition, upon the completion of this offering, Mr. Visconti will be granted a stock option to purchase 400,000 shares of our common stock under our 2022 Plan, which will vest *pro rata* on a monthly basis over a three-year period subject to continued employment through each vesting date.

The Visconti Employment Agreement provides that Mr. Visconti will be eligible to participate in all benefit and fringe benefit plans generally made available to Twin Vee's other executive officers. In addition, he is entitled to (i) four weeks of paid vacation per year, (ii) a \$2,500 a month car allowance and (iii) the cost of medical insurance for coverage for Mr. Visconti and his family.

The Visconti Employment Agreement provides that it shall continue until terminated (i) by mutual agreement; (ii) due to death or disability of Mr. Visconti; (iii) by Mr. Visconti without good reason upon 90 days written notice to us; (iv) by us for cause (as defined in the Visconti Employment Agreement); (v) by Twin Vee without cause; or (vi) by Mr. Visconti for good reason (as defined in the Visconti Employment Agreement).

Pursuant to the Visconti Employment Agreement, Mr. Visconti is subject to a one-year post-termination non-compete and non-solicit of employees and clients. He is also bound by confidentiality provisions.

In the event of a termination by Twin Vee without cause or a termination by Mr. Visconti for good reason other than in connection with a change in control, Mr. Visconti will receive: an aggregate of twelve months of salary continuation at his then-current base annual salary, paid out in equal installments over a 6 month period; payment of any amount of annual bonus accrued for the year prior to the date of termination; payment of the bonus Mr. Visconti would have received based on the attainment of performance goals had he remained employed through the end of the year of termination, pro-rated based on the number of days in the termination year that Mr. Visconti was employed by Twin Vee (paid when its other senior executives receive payment of their annual bonuses); reimbursement of COBRA premiums for up to twelve months; and full vesting for any outstanding, unvested equity awards granted under the Twin Vee 2021 Plan and our 2022 Plan. Mr. Visconti's outstanding vested stock options in Twin Vee and Forza X1 will generally remain exercisable no longer than six months following such a termination.

In the event of a termination by Twin Vee without cause or a resignation by Mr. Visconti for good reason within twelve months following a change in control, Mr. Visconti will receive an aggregate of 18 months of salary continuation at his then-current base annual salary, paid out in equal installments over a twelve month period; payment of any amount of annual bonus accrued for the year prior to the year of termination; payment of a pro-rated target annual bonus for the year of termination based on the number of days in the termination year that Mr. Visconti was employed by Twin Vee; payment of one time his then-current target annual bonus; reimbursement of COBRA premiums for up to 18 months; and full vesting for any outstanding, unvested equity awards granted under the Twin Vee 2021 Plan and our 2022 Plan. Mr. Visconti's outstanding vested stock options will generally remain exercisable no longer than six months following such a termination.

The receipt of any termination benefits described above is subject to Mr. Visconti's execution of a release of claims in favor of the Company, a form of which is attached as an exhibit to the Visconti Employment Agreement.

In the event of Mr. Visconti's termination due to death or disability, Mr. Visconti will receive full vesting for any outstanding, unvested equity awards granted under Twin Vee's 2021 Plan and our 2022 Plan. Mr. Visconti's outstanding vested stock options will generally remain exercisable no longer than six months following such a termination.

Preston Yarborough

Employment Agreement

Twin Vee entered into a five-year employment agreement with Mr. Yarborough (the "Yarborough Employment Agreement") effective upon its initial public offering in July 2021. Under the Yarborough Employment Agreement, Mr. Yarborough serves as Twin Vee's Vice President and Director of Product Development. He receives an annual base salary of \$160,000 and is eligible to receive an annual performance cash bonus with a target amount equal to 50% of his annual base salary, based upon achievement of performance goals established by the compensation committee of Twin Vee's board of directors. Upon the completion of Twin Vee's offering, Mr. Yarborough received a stock option to purchase 136,000 shares of Twin Vee's common stock under its 2021 Plan, vesting monthly over a three-year period subject to continued employment through each

vesting date. In addition, upon the completion of this offering, Mr. Yarborough will be granted a stock option to purchase 100,000 shares of common stock under our 2022 Plan, which will vest monthly over a three-year period subject to continued employment through each vesting date.

The Yarborough Employment Agreement provides that Mr. Yarborough would be eligible to participate in all benefit and fringe benefit plans generally made available to Twin Vee's other executive officers. In addition, he is entitled to (i) four weeks of paid vacation per year, (ii) a \$1,000 a month car allowance and (iii) the cost of medical insurance for coverage for Mr. Yarborough and his family.

The Yarborough Employment Agreement provides that it shall continue until terminated (i) by mutual agreement; (ii) due to death or disability of Mr. Yarborough; (iii) by Mr. Yarborough without good reason upon 90 days written notice to Twin Vee; (iv) by Twin Vee for cause (as defined in the Yarborough Employment Agreement); (v) by Twin Vee without cause; or (vi) by Mr. Yarborough for good reason (as defined in the Yarborough Employment Agreement).

Pursuant to the Yarborough Employment Agreement, Mr. Yarborough is subject to a one-year post-termination non-compete and non-solicit of employees and clients. He is also bound by confidentiality provisions.

In the event of a termination by Twin Vee without cause or a termination by Mr. Yarborough for good reason other than in connection with a change in control, Mr. Yarborough will receive: an aggregate of nine months of salary continuation at his then-current base annual salary, paid out in equal installments over a six month period; payment of any amount of annual bonus accrued for the year prior to the date of termination; payment of the bonus Mr. Yarborough would have received based on the attainment of performance goals had he remained employed through the end of the year of termination, pro-rated based on the number of days in the termination year that Mr. Yarborough was employed by Twin Vee (paid when Twin Vee's other senior executives receive payment of their annual bonuses); reimbursement of COBRA premiums for up to nine months; and full vesting for any outstanding, unvested equity awards granted under the Twin Vee 2021 Plan and our 2022 Plan. Mr. Yarborough's outstanding vested stock options will generally remain exercisable no longer than six months following such a termination.

In the event of a termination by Twin Vee without cause or a resignation by Mr. Yarborough for good reason within twelve months following a change in control, Mr. Yarborough will receive an aggregate of twelve months of salary continuation at his then-current base annual salary, paid out in equal installments over a twelve month period; payment of any amount of annual bonus accrued for the year prior to the year of termination; payment of a pro-rated target annual bonus for the year of termination based on the number of days in the termination year that Mr. Yarborough was employed by Twin Vee; payment of one time his then-current target annual bonus; reimbursement of COBRA premiums for up to twelve months; and full vesting for any outstanding, unvested equity awards granted under the Twin Vee 2021 Plan and our 2022 Plan. Mr. Yarborough's outstanding vested stock options will generally remain exercisable no longer than six months following such a termination.

The receipt of any termination benefits described above is subject to Mr. Yarborough's execution of a release of claims in favor of the Company, a form of which is attached as an exhibit to the Yarborough Employment Agreement.

In the event of Mr. Yarborough's termination due to death or disability, Mr. Yarborough will receive full vesting for any outstanding, unvested equity awards granted under Twin Vee's 2021 Plan and our 2022 Plan. Mr. Yarborough's outstanding vested stock options will generally remain exercisable no longer than six months following such a termination.

Carrie Gunnerson

Employment Agreement

Twin Vee entered into a five-year employment agreement with Ms. Gunnerson (the "Gunnerson Employment Agreement") effective in October 2021. Under the Gunnerson Employment Agreement, Ms. Gunnerson serves as Twin Vee's Chief Financial Officer. She receives an annual base salary of \$175,000 and is eligible to receive an annual performance cash bonus with a target amount equal to 30% of her annual base salary, based upon achievement of performance goals established by the compensation committee of Twin Vee's board of directors. Ms. Gunnerson also received a stock option to purchase 136,000 shares of Twin Vee's common stock under its 2021 Plan, vesting monthly over a five-year period subject to continued employment through each vesting date. In addition, upon the completion of this offering, Ms. Gunnerson will be granted a stock option to purchase 100,000 shares of common stock under our 2022 Plan, which will vest monthly over a three-year period subject to continued employment through each vesting date.

The Gunnerson Employment Agreement provides that Ms. Gunnerson would be eligible to participate in all benefit and fringe benefit plans generally made available to Twin Vee's other executive officers. In addition, she is entitled to four weeks of paid vacation per year.

The Gunnerson Employment Agreement provides that it shall continue until terminated (i) by mutual agreement; (ii) due to death or disability of Ms. Gunnerson; (iii) by Ms. Gunnerson without good reason upon 90 days written notice to Twin Vee; (iv) by Twin Vee for cause (as defined in the Gunnerson Employment Agreement); (v) by Twin Vee without cause; or (vi) by Ms. Gunnerson for good reason (as defined in the Gunnerson Employment Agreement).

Pursuant to the Gunnerson Employment Agreement, Ms. Gunnerson is subject to a one-year post-termination non-compete and non-solicit of employees and clients. She is also bound by confidentiality provisions.

In the event of a termination by Twin Vee without cause or a termination by Ms. Gunnerson for good reason during the first six (6) months following the effective date of the Gunnerson Employment Agreement, Ms. Gunnerson will receive an aggregate of three months of salary continuation at her then-current base annual salary, paid out in equal installments over a three-month period. In the event of a termination by Twin Vee without cause or a termination by Ms. Gunnerson for good reason after the first six (6) months following the effective date of the Gunnerson Employment Agreement, Ms. Gunnerson will receive an aggregate of six months of salary continuation at her then-current base annual salary, paid out in equal installments over a six-month period. Ms. Gunnerson's outstanding vested stock options will generally remain exercisable no longer than six months following such a termination.

The receipt of any termination benefits described above is subject to Ms. Gunnerson's execution of a release of claims in favor of the Company, a form of which is attached as an exhibit to the Gunnerson Employment Agreement.

In the event of Ms. Gunnerson's termination due to death or disability, Ms. Gunnerson will receive full vesting or any outstanding, unvested equity awards granted under Twin Vee's 2021 Plan and our 2022 Plan. Ms. Gunnerson's outstanding vested stock options will generally remain exercisable no longer than six months following such a termination.

2022 Stock Incentive Plan

We intend to adopt the Forza X1 2022 Stock Incentive Plan, or the 2022 Plan. The 2022 Plan will become effective immediately prior to the closing of the Company's initial

public offering described herein. The principal provisions of the 2022 Plan are summarized below.

Administration

The 2022 Plan vests broad powers in a committee to administer and interpret the 2022 Plan. Our board of directors has initially designated the compensation committee to administer the 2022 Plan. Except when limited by the terms of the 2022 Plan, the compensation committee has the authority to, among other things: select the persons to be granted awards; determine the type, size and term of awards; establish performance objectives and conditions for earning awards; determine whether such performance objectives and conditions have been met; and accelerate the vesting or exercisability of an award. In its discretion, the compensation committee may delegate all or part of its authority and duties with respect to granting awards to one or more of our officers, subject to certain limitations and provided applicable law so permits.

Our board of directors may amend, alter or discontinue the 2022 Plan and the compensation committee may amend any outstanding award at any time; provided, however, that no such amendment or termination may adversely affect awards then outstanding without the holder's permission. In addition, any amendments seeking to increase the total number of shares reserved for issuance under the 2022 Plan or modifying the classes of participants eligible to receive awards under the 2022 Plan will require ratification by our stockholders in accordance with applicable law. Additionally, as described more fully below, neither the compensation committee nor the board of directors is permitted to reprice outstanding options or stock appreciation rights without shareholder consent.

Eligibility

Any of our employees, directors, consultants, and other service providers, or those of our affiliates, are eligible to participate in the 2022 Plan and may be selected by the compensation committee to receive an award.

Vesting

The compensation committee determines the vesting conditions for awards. These conditions may include the continued employment or service of the participant, the attainment of specific individual or corporate performance goals, or other factors as determined in the compensation committee's discretion (collectively, "Vesting Conditions").

Shares of Stock Available for Issuance

Subject to certain adjustments, the maximum number of shares of common stock that may be issued under the 2022 Plan in connection with awards is 1,000,000 shares. We will issue options to purchase an aggregate of 492,500 shares of our common stock upon the consummation of this offering. In addition, the maximum number of shares of common stock that may be issued under the 2022 Plan will automatically increase on January 1 of each calendar year for a period of ten years commencing on January 1, 2023 and ending on (and including) January 1, 2032, in a number of shares of common stock equal to 4.5% of the total number of shares of common stock outstanding on December 31 of the preceding calendar year; provided, however that the board of directors may act prior to January 1 of a given calendar year to provide that the increase for such year will be a lesser number of shares of common stock. All available shares may be utilized toward the grant of any type of award under the 2022 Plan. The 2022 Plan imposes a \$250,000 limitation on the total grant date fair value of awards granted to any non-employee director in his or her capacity as a non-employee director in any single calendar year.

In the event of any merger, consolidation, reorganization, recapitalization, stock split, reverse stock split, split up, spin-off, combination of shares, exchange of shares, stock dividend, dividend in kind, or other like change in capital structure (other than ordinary cash dividends), or other similar corporate event or transaction that affects our common stock, the compensation committee shall make adjustments to the number and kind of shares authorized by the 2022 Plan and covered under outstanding 2022 Plan awards as it determines appropriate and equitable.

Shares subject to 2022 Plan awards that expire without being fully exercised or that are otherwise forfeited, cancelled or terminated may again be made available for issuance under the 2022 Plan. However, shares withheld in settlement of a tax withholding obligation, or in satisfaction of the exercise price payable upon exercise of an option, will not again become available for issuance under the 2022 Plan.

Types of Awards

The following types of awards may be granted to participants under the 2022 Plan: (i) incentive stock options, or ISOs; (ii) nonqualified stock options, or NQOs and together with ISOs, options, (iii) stock appreciation rights, (iv) restricted stock, or (v) restricted stock units.

Stock Options. An option entitles the holder to purchase from us a stated number of shares of common stock. An ISO may only be granted to an employee of ours or our eligible affiliates. The compensation committee will specify the number of shares of common stock subject to each option and the exercise price for such option, provided that the exercise price may not be less than the fair market value of a share of common stock on the date the option is granted. Notwithstanding the foregoing, if ISOs are granted to any 10% stockholder, the exercise price shall not be less than 110% of the fair market value of common stock on the date the option is granted.

Generally, options may be exercised in whole or in part through a cash payment. The compensation committee may, in its sole discretion, permit payment of the exercise price of an option in the form of previously acquired shares based on the fair market value of the shares on the date the option is exercised, through means of "net settlement," which involves the cancellation of a portion of the option to cover the cost of exercising the balance of the option or by such other means as it deems acceptable.

All options shall be or become exercisable in accordance with the terms of the applicable award agreement. The maximum term of an option shall be determined by the compensation committee on the date of grant but shall not exceed 10 years (5 years in the case of ISOs granted to any 10% stockholder). In the case of ISOs, the aggregate fair market value (determined as of the date of grant) of common stock with respect to which such ISOs become exercisable for the first time during any calendar year cannot exceed \$100,000. ISOs granted in excess of this limitation will be treated as non-qualified stock options.

Stock Appreciation Rights. A stock appreciation right represents the right to receive, upon exercise, any appreciation in a share of common stock over a particular time period. The base price of a stock appreciation right shall not be less than the fair market value of a share of common stock on the date the stock appreciation right is granted. This award is intended to mirror the benefit the participant would have received if the compensation committee had granted the participant an option. The maximum term of a stock appreciation right shall be determined by the compensation committee on the date of grant but shall not exceed 10 years. Distributions with respect to stock appreciation rights may be made in cash, shares of common stock, or a combination of both, at the compensation committee's discretion.

Unless otherwise provided in an award agreement or determined by the compensation committee, if a participant terminates employment with us (or our affiliates) due to death or disability, the participant's unexercised options and stock appreciation rights may be exercised, to the extent they were exercisable on the termination date, for a period of twelve months from the termination date or until the expiration of the original award term, whichever period is shorter. If the participant terminates employment with us (or our affiliates) for cause, (i) all unexercised options and stock appreciation rights (whether vested or unvested) shall terminate and be forfeited on the termination date, and (ii) any shares in respect of exercised options or stock appreciation rights for which we have not yet delivered share certificates will be forfeited and we will refund to the participant the option exercise price paid for those shares, if any. If the participant's employment terminates for any other reason, any vested but unexercised options and stock appreciation rights may be exercised by the participant, to the extent exercisable at the time of termination, for a period of ninety days from the termination date (or such time as specified by the compensation committee at or after grant) or until the expiration of the original option or stock appreciation right term, whichever period is shorter. Unless otherwise provided by the compensation committee, any options and stock appreciation rights that are not exercisable at the time of termination of employment shall terminate and be

Restricted Stock. A restricted stock award is a grant of shares of common stock, which are subject to forfeiture restrictions during a restriction period. The compensation committee will determine the price, if any, to be paid by the participant for each share of common stock subject to a restricted stock award. The restricted stock may be subject to Vesting Conditions. If the specified Vesting Conditions are not attained, the participant will forfeit the portion of the restricted stock award with respect to which those conditions are not attained, and the underlying common stock will be forfeited to us. At the end of the restriction period, if the Vesting Conditions have been satisfied, the restrictions imposed will lapse with respect to the applicable number of shares. Unless otherwise provided in an award agreement or determined by the compensation committee, upon termination a participant will forfeit all restricted stock that then remains subject to forfeiture restrictions.

Restricted Stock Units. Restricted stock units are granted in reference to a specified number of shares of common stock and entitle the holder to receive, on the achievement of applicable Vesting Conditions, shares of common stock. Unless otherwise provided in an award agreement or determined by the Compensation committee, upon termination a participant will forfeit all restricted stock units that then remain subject to forfeiture.

Change in Control

In the event of a change in control, the compensation committee may, on a participant-by-participant basis: (i) cause any or all outstanding awards to become vested and immediately exercisable (as applicable), in whole or in part; (ii) cause any outstanding option or stock appreciation right to become fully vested and immediately exercisable for a reasonable period in advance of the change in control and, to the extent not exercised prior to that change in control, cancel that option or stock appreciation right upon closing of the change in control; (iii) cancel any unvested award or unvested portion thereof, with or without consideration; (iv) cancel any award in exchange for a substitute award; (v) redeem any restricted stock or restricted stock unit for cash and/or other substitute consideration with value equal to the fair market value of an unrestricted share on the date of the change in control; (vi) cancel any outstanding option or stock appreciation right with respect to all common stock for which the award remains unexercised in exchange for a cash payment equal to the excess (if any) of the fair market value of the common stock subject to the option or stock appreciation right over the exercise price of the option or stock appreciation right; (vii) impose vesting terms on cash or substitute consideration payable upon cancellation of an award that are substantially similar to those that applied to the cancelled award immediately prior to the change in control, and/or earn-out, escrow, holdback or similar arrangements, to the extent such arrangements are applicable to any consideration paid to stockholders in connection with the change in control; (viii) take such other action as the compensation committee shall determine to be reasonable under the circumstances; and/or (ix) in the case of any award subject to Section 409A of the Code, the compensation committee shall only be permitted to use discretion to alter the settlement timing of the award to the extent that such discretion would be permitted under Section 409A of the Code.

Repricing

Neither our board of directors nor the compensation committee may, without obtaining prior approval of our stockholders: (i) implement any cancellation/re-grant program pursuant to which outstanding options or stock appreciation rights under the 2022 Plan are cancelled and new options or stock appreciation rights are granted in replacement with a lower exercise per share; (ii) cancel outstanding options or stock appreciation rights under the 2022 Plan with an exercise price per share in excess of the then current fair market value per share for consideration payable in our equity securities; or (iii) otherwise directly reduce the exercise price in effect for outstanding options or stock appreciation rights under the 2022 Plan.

Miscellaneous

Generally, awards granted under the 2022 Plan shall be nontransferable except by will or by the laws of descent and distribution. No participant shall have any rights as a stockholder with respect to shares covered by options or restricted stock units, unless and until such awards are settled in shares of common stock. The Company's obligation to issue shares or to otherwise make payments in respect of 2022 Plan awards will be conditioned on the Company's ability to do so in compliance with all applicable laws and exchange listing requirements. The awards will be subject to our recoupment and stock ownership policies, as may be in effect from time to time. The 2022 Plan will expire 10 years after it becomes effective.

Grants Contingent on Effectiveness of the Offering

The Company will grant stock options to purchase 400,000 shares of our common stock to Mr. Visconti, stock options to purchase 400,000 shares of our common stock to Mr. Leffew, stock options to purchase 100,000 shares of our common stock to Ms. Gunnerson, and stock options to purchase 100,000 shares of our common stock to Mr. Yarborough under our 2022 Stock Incentive Plan upon the closing this offering, as described in the section titled "Employment Arrangements with Our Named Executive Officers" above. In addition, upon the initial public offering, all non-employee directors will receive initial grants of non-qualified stock options under the 2022 Plan, as described in the section entitled "Equity Compensation" above. All of the benefits that will be awarded or paid under the 2022 Plan are at the discretion of the compensation committee of the board of directors and except for the stock option awards noted above, no other awards have been approved under the 2022 Plan.

CERTAIN RELATIONSHIPS AND RELATED PARTY TRANSACTIONS

Each of the related party transactions described below was negotiated on an arm's length basis. We believe that the terms of such agreements are as favorable as those we could have obtained from parties not related to us. The following are summaries of certain provisions of our related party agreements and are qualified in their entirety by reference to all of the provisions of such agreements. Because these descriptions are only summaries of the applicable agreements, they do not necessarily contain all of the information that you may find useful. We therefore urge you to review the agreements in their entirety. Copies of the forms of the agreements have been filed as exhibits to the registration statement of which this prospectus is a part and are available electronically on the website of the SEC at www.sec.gov.

In addition to the compensation arrangements, including employment, termination of employment and change in control arrangements, with our directors and executive officers, including those discussed in the sections titled "Management" and "Executive Compensation," the following is a description of each transaction since January 1, 2019 or any currently proposed transaction in which:

- we have been or are to be a party to;
- the amount involved exceeded or exceeds \$120,000 or 1% of the average of our total assets as of the end of the last two completed fiscal years; and
- any of our directors, executive officers or holders of more than 5% of our outstanding capital stock, or any immediate family member of, or person sharing the household with, any of these individuals or entities, had or will have a direct or indirect material interest.

For information on our compensation arrangements, including employment, termination of employment and change in control arrangements, with our directors and executive officers, see the sections titled "Management" and "Executive Compensation."

On December 3, 2021, we had \$596,512 due Twin Vee. Our parent company funded our working capital needs, primarily for prototyping, consulting services and payroll, prior to their \$2,000,000 investment.

During the period of inception (October 15, 2021) through December 31, 2021, we recorded management fees of \$15,000; paid to Twin Vee pursuant to a management agreement, dated October 1, 2021, with it for various management services. The agreement provides for a monthly \$5,000 management fee, has a term of one year and will expire on September 30, 2022. The management services include human resources, accounting services, investor relations, shareholder relations, consultation during the initial public offering process and review of the assets owned and operated by us. It is anticipated that following the completion of this offering we will transition the management agreement with Twin Vee from an agreement providing management services to an administrative services agreement under which Twin Vee would provide us with certain administrative services, such as procurement, shipping, receiving, storage and use of Twin Vee's facility until our new planned facility is completed, and that we will enter into separate employment agreements with Mr. Visconti, Ms. Gunnerson and Mr. Yarborough to compensate them directly for the services provided to us based on the relative time spent on our matters and Twin Vee matters.

Our corporate headquarters is located at our parent company's premises, in addition to the above management fee, we have a month-to-month arrangement and pay Twin Vee rent of \$850 per month.

Indemnification Agreements

We intend to enter, into separate indemnification agreements with each of our directors and executive officers, in addition to the indemnification that will be provided for in our certificate of incorporation and bylaws. The indemnification agreements and our amended restated certificate of incorporation and bylaws that will be in effect upon the completion of this offering require us to indemnify our directors, executive officers and certain controlling persons to the fullest extent permitted by Delaware law. See the section titled "Description of Capital Stock--Limitations on Liability and Indemnification of Officers and Directors" for additional information.

Our Policy Regarding Related Party Transactions

Our board of directors recognizes the fact that transactions with related persons present a heightened risk of conflicts of interest and/or improper valuation (or the perception thereof). Prior to the closing of this offering, our board of directors will adopt a written policy on transactions with related persons that is in conformity with the requirements for issuers having publicly held common stock that is listed on the Nasdaq Stock Market. Under the new policy:

- any related person transaction, and any material amendment or modification to a related person transaction, must be reviewed and approved or ratified by the Audit Committee; and
- any employment relationship or transaction involving an executive officer and any related compensation must be approved by the compensation committee of the board of directors or recommended by the compensation committee to the board of directors for its approval.

In connection with the review and approval or ratification of a related person transaction:

- management must disclose to the committee or disinterested directors, as applicable, the name of the related person and the basis on which the person is a related person, the material terms of the related person transaction, including the approximate dollar value of the amount involved in the transaction, and all the material facts as to the related person's direct or indirect interest in, or relationship to, the related person transaction;
- management must advise the committee or disinterested directors, as applicable, as to whether the related person transaction complies with the terms of our agreements governing our material outstanding indebtedness that limit or restrict our ability to enter into a related person transaction;
- management must advise the committee or disinterested directors, as applicable, as to whether the related person transaction will be required to be disclosed in our applicable filings under the Securities Act or the Exchange Act, and related rules, and, to the extent required to be disclosed, management must ensure that the related person transaction is disclosed in accordance with the Securities Act and the Exchange Act and related rules; and
- management must advise the committee or disinterested directors, as applicable, as to whether the related person transaction constitutes a "personal loan" for purposes of Section 402 of the Sarbanes-Oxley Act.

In addition, the related person transaction policy provides that the committee or disinterested directors, as applicable, in connection with any approval or ratification of a related person transaction involving a non-employee director, should consider whether such transaction would compromise the director's status as an "independent," "outside," or "non-employee" director, as applicable, under the rules and regulations of the SEC, the Nasdaq Stock Market, and the Code.

PRINCIPAL STOCKHOLDERS

The following table sets forth the beneficial ownership of our common stock as of December , 2021, by:

- each person, or group of affiliated persons, who is known by us to beneficially own more than 5% of our common stock;
- each of the named executive officers;
- each of our directors; and
- all of our current executive officers and directors as a group.

We have determined beneficial ownership in accordance with the rules of the SEC, and thus it represents sole or shared voting or investment power with respect to our securities. Unless otherwise indicated below, to our knowledge, the persons and entities named in the table have sole voting and sole investment power with respect to all shares that they beneficially owned, subject to community property laws where applicable. The information does not necessarily indicate beneficial ownership for any other purpose, including for purposes of Sections 13(d) and 13(g) of the Exchange Act.

We have based our calculation of the percentage of beneficial ownership prior to this offering on shares of our common stock outstanding as of December , 2021. We have based our calculation of the percentage of beneficial ownership after this offering on shares of our common stock outstanding immediately after the completion of this offering, assuming no exercise by the underwriters of their option to purchase additional shares and based on an assumed initial public offering price of \$ _____ per share, which is the midpoint of the estimated offering price range set forth on the cover page of this prospectus. We have deemed shares of our common stock subject to stock options that are

currently exercisable or exercisable within 60 days of December, 2021, to be outstanding and to be beneficially owned by the person holding the stock option for the purpose of computing the percentage ownership of that person. We did not deem these shares outstanding, however, for the purpose of computing the percentage ownership of any other person. Unless otherwise indicated, the address of each beneficial owner listed in the table below is c/o Forza X1, Inc., 3101 S. US-1 Ft. Pierce, Florida 34982.

Name of Beneficial Owner	Shares Beneficially Owned Prior to this Offering		Shares Beneficially Owned After this Offering	
	Shares	Percentage	Shares	Percentage
Named Executive Officers and Directors				
Joseph Visconti ⁽¹⁾	2,083,636	32.1%		%
Carrie Gunnerson	—	—		
Jim Leffew	—	—		
Neil Ross				
Preston Yarborough	—	—		
Bard Rockenbach	—	—		
Kevin Schuyler	—	—		
Steven Shallcross	—	—		
All executive officers and directors as a group (8 persons)	2,083,636	32.1%		
5% Stockholders				
Twin Vee Powercats Co. and Twin Vee PowerCats, Inc. ⁽¹⁾	6,500,000	100%		%

* Represents beneficial ownership of less than one percent.

(1) Joseph Visconti is the Chairman of the Board and Chief Executive Officer of our parent company, Twin Vee Powercats Co., and is the Chairman of the Board and Chief Executive Officer of, Twin Vee PowerCats, Inc., the parent company of Twin Vee Powercats Co. These shares are owned directly by Twin Vee Powercats Co., which is a majority owned subsidiary of Twin Vee Powercats, Inc. Mr. Visconti owns 56.14% of the outstanding stock of Twin Vee Powercats, Inc. and Twin Vee Powercats, Inc. owns 57.1% of the outstanding stock of Twin Vee Powercats Co. Twin Vee Powercats Co. is the owner of 6,500,000 shares of common stock, which prior to this offering represents all of our outstanding shares of common stock. As a controlling shareholder of Twin Vee Powercats Co., Mr. Visconti is deemed to have control over the shares of common stock of our company owned by Twin Vee Powercats Co. Mr. Visconti disclaims beneficial ownership of these securities.

DESCRIPTION OF CAPITAL STOCK

The following description of our capital stock and the provisions of our certificate of incorporation and our bylaws are summaries and are qualified by reference to the certificate of incorporation and the bylaws that will be in effect upon the closing of this offering. We have filed copies of these documents with the SEC as exhibits to our registration statement of which this prospectus forms a part. The descriptions of the common stock and preferred stock reflect changes to our capital structure that will occur prior to and upon the closing of this offering.

General

Upon the closing of this offering, our authorized capital stock will consist of:

- 25,000,000 shares of common stock, par value \$0.001 per share; and
- 5,000,000 shares of preferred stock, par value \$0.001 per share.

We are selling shares of common stock in this offering based on an assumed initial public offering price of \$ _____ per share, which is the midpoint of the estimated offering price range set forth on the cover page of this prospectus. All of our common stock outstanding upon consummation of this offering will be fully paid and non-assessable.

The following description of our capital stock and provisions of our certificate of incorporation and by-laws are summaries and are qualified by reference to the certificate of incorporation and by-laws. We urge you to read our certificate and our by-laws, as in effect immediately following the closing of this offering, which are included as exhibits to the registration statement of which this prospectus forms a part.

Certain provisions of our certificate and our by-laws summarized below may be deemed to have an anti-takeover effect and may delay or prevent a tender offer or takeover attempt that a stockholder might consider in its best interest, including those attempts that might result in a premium over the market price for the shares of common stock.

Common Stock

Holders of shares of our common stock are entitled to one vote for each share held of record on all matters submitted to a vote of stockholders. Except as otherwise provided in our amended and restated certificate of incorporation or as required by law, all matters to be voted on by our stockholders other than matters relating to the election and removal of directors must be approved by a majority of the shares present in person or by proxy at the meeting and entitled to vote on the subject matter or by a written resolution of the stockholders representing the number of affirmative votes required for such matter at a meeting. The holders of our common stock do not have cumulative voting rights in the election of directors.

Holders of shares of our common stock are entitled to receive dividends when and if declared by our board of directors out of funds legally available therefor, subject to any statutory or contractual restrictions on the payment of dividends and to any restrictions on the payment of dividends imposed by the terms of any outstanding preferred stock.

Upon our dissolution or liquidation or the sale of all or substantially all of our assets, after payment in full of all amounts required to be paid to creditors and subject to any rights of preferred stockholders, the holders of shares of our common stock will be entitled to receive pro rata our remaining assets available for distribution.

Holders of shares of our common stock do not have preemptive, subscription, redemption, or conversion rights. There will be no redemption or sinking fund provisions applicable to the common stock.

Preferred Stock

Our Board of Directors has the authority, without action by our stockholders, to designate and issue up to 5,000,000 shares of preferred stock in one or more series or classes

and to designate the rights, preferences and privileges of each series or class, which may be greater than the rights of our common stock. There are no shares of preferred stock designated or outstanding. It is not possible to state the actual effect of the issuance of any shares of preferred stock upon the rights of holders of our common stock until our Board of Directors determines the specific rights of the holders of the preferred stock. However, the effects might include:

- restricting dividends on our common stock;
- diluting the voting power of our common stock;
- impairing liquidation rights of our common stock; or
- delaying or preventing a change in control of us without further action by our stockholders.

The Board of Directors' authority to issue preferred stock without stockholder approval could make it more difficult for a third-party to acquire control of our company and could discourage such attempt. We have no present plans to issue any shares of preferred stock.

Forum Selection

Our certificate of incorporation provides that unless we consent in writing to the selection of an alternative forum, the Court of Chancery of the State of Delaware will, to the fullest extent permitted by applicable law, be the sole and exclusive forum for (i) any derivative action or proceeding brought on our behalf; (ii) any action asserting a claim of breach of a fiduciary duty owed by any of our directors, officers or other employees to us or our stockholders; (iii) any action asserting a claim against us, any director or our officers or employees arising pursuant to any provision of the DGCL, our certificate of incorporation or our by-laws; or (iv) any action asserting a claim against us, any director or our officers or employees that is governed by the internal affairs doctrine, except, as to each of clauses (i) through (iv) above, for any claim as to which the Court of Chancery determines that there is an indispensable party not subject to the jurisdiction of the Court of Chancery (and the indispensable party does not consent to the personal jurisdiction of the Court of Chancery within ten (10) days following such determination), which is vested in the exclusive jurisdiction of a court or forum other than the Court of Chancery, or for which the Court of Chancery does not have subject matter jurisdiction. The certificate of incorporation further provides that the choice of the Court of Chancery as the sole and exclusive forum for any derivative action or proceeding brought on behalf of the Corporation does not apply to suits to enforce a duty or liability created by the Securities Act or the Exchange Act.

Anti-Takeover Provisions

Our certificate of incorporation and by-laws contain provisions that may delay, defer, or discourage another party from acquiring control of us. We expect that these provisions, which are summarized below, will discourage coercive takeover practices or inadequate takeover bids. These provisions are also designed to encourage persons seeking to acquire control of us to first negotiate with our board of directors, which we believe may result in an improvement of the terms of any such acquisition in favor of our stockholders. However, they also give our board of directors the power to discourage acquisitions that some stockholders may favor.

Section 203 of the Delaware General Corporation Law. We are subject to Section 203 of the Delaware General Corporation Law. Subject to certain exceptions, Section 203 prevents a publicly held Delaware corporation from engaging in a "business combination" with any "interested stockholder" for three years following the date that the person became an interested stockholder, unless the interested stockholder attained such status with the approval of our board of directors or unless the business combination is approved in a prescribed manner. A "business combination" includes, among other things, a merger or consolidation involving us and the "interested stockholder" and the sale of more than 10% of our assets. In general, an "interested stockholder" is any entity or person beneficially owning 15% or more of our outstanding voting stock and any entity or person affiliated with or controlling or controlled by such entity or person.

Classified Board of Directors. Our certificate divides our board of directors into staggered three-year terms. In addition, our certificate and our by-laws provide that directors may be removed only for cause. Under our certificate and by-laws, any vacancy on our board of directors, including a vacancy resulting from an enlargement of our board of directors, may be filled only by the affirmative vote of a majority of our directors then in office, even though less than a quorum of the board of directors. The classification of our board of directors and the limitations on the ability of our stockholders to remove directors and fill vacancies could make it more difficult for a third party to acquire, or discourage a third party from seeking to acquire, control of us.

Authorized but Unissued Shares. The authorized but unissued shares of our common stock are available for future issuance without stockholder approval, subject to any limitations imposed by the listing standards of the Nasdaq Stock Market. These additional shares may be used for a variety of corporate finance transactions, acquisitions, and employee benefit plans. The existence of authorized but unissued and unreserved common stock could make it more difficult or discourage an attempt to obtain control of us by means of a proxy contest, tender offer, merger, or otherwise.

Stockholder Action by Written Consent. Our certificate and our by-laws provide that any action required or permitted to be taken by our stockholders at an annual meeting or special meeting of stockholders may only be taken if it is properly brought before such meeting and may be taken by written consent in lieu of a meeting only if the action to be effected by such written consent and the taking of such action by such written consent have been previously approved by the board of directors.

Special Meetings of Stockholders. Our by-laws also provide that, except as otherwise required by law, special meetings of the stockholders may only be called by our board of directors.

Advance Notice Requirements for Stockholder Proposals and Director Nominations. In addition, our by-laws establish an advance notice procedure for stockholder proposals to be brought before an annual meeting of stockholders, including proposed nominations of candidates for election to our board of directors. In order for any matter to be "properly brought" before a meeting, a stockholder will have to comply with advance notice and duration of ownership requirements and provide us with certain information. Stockholders at an annual meeting may only consider proposals or nominations specified in the notice of meeting or brought before the meeting by or at the direction of our board of directors or by a qualified stockholder of record on the record date for the meeting, who is entitled to vote at the meeting and who has delivered timely written notice in proper form to our secretary of the stockholder's intention to bring such business before the meeting. These provisions could have the effect of delaying stockholder actions that are favored by the holders of a majority of our outstanding voting securities until the next stockholder meeting.

Amendment of Certificate of Incorporation or By-laws. The Delaware General Corporation Law provides generally that the affirmative vote of a majority of the shares entitled to vote on any matter is required to amend a corporation's certificate of incorporation or by-laws, unless a corporation's certificate of incorporation or by-laws, as the case may be, requires a greater percentage. Upon completion of this offering, our bylaws may be amended or repealed by a majority vote of our board of directors or by the affirmative vote of the holders of at least 66 2/3% of the votes which all our stockholders would be eligible to cast in an election of directors. In addition, the affirmative vote of the holders of at least 66 2/3% of the votes which all our stockholders would be eligible to cast in an election of directors will be required to amend or repeal or to adopt any provisions inconsistent with any of the provisions of our certificate described in the prior three paragraphs.

Limitations on Liability and Indemnification of Officers and Directors

Our certificate and by-laws provide indemnification for our directors and officers to the fullest extent permitted by the Delaware General Corporation Law. Prior to the completion of this offering, we intend to enter into indemnification agreements with each of our directors that may, in some cases, be broader than the specific indemnification provisions contained under Delaware law. In addition, as permitted by Delaware law, our certificate includes provisions that eliminate the personal liability of our directors for

monetary damages resulting from breaches of certain fiduciary duties as a director. The effect of these provisions is to restrict our rights and the rights of our stockholders in derivative suits to recover monetary damages against a director for breach of fiduciary duties as a director, except that a director will be personally liable for:

- any breach of his duty of loyalty to us or our stockholders;
- acts or omissions not in good faith or which involve intentional misconduct or a knowing violation of law;
- any transaction from which the director derived an improper personal benefit; or
- improper distributions to stockholders.

These limitations of liability do not apply to liabilities arising under the federal or state securities laws and do not affect the availability of equitable remedies such as injunctive relief or rescission.

Our bylaws provide that we will indemnify our directors and officers to the fullest extent permitted by law, and may indemnify employees and other agents. Our bylaws also provide that we are obligated to advance expenses incurred by a director or officer in advance of the final disposition of any action or proceeding.

We plan to enter into separate indemnification agreements with our directors and officers. These agreements, among other things, require us to indemnify our directors and officers for any and all expenses (including reasonable attorneys' fees, retainers, court costs, transcript costs, fees of experts, witness fees, travel expenses, duplicating costs, printing and binding costs, telephone charges, postage, delivery service fees) judgments, fines and amounts paid in settlement actually and reasonably incurred by such directors or officers or on his or her behalf in connection with any action or proceeding arising out of their services as one of our directors or officers, or any of our subsidiaries or any other company or enterprise to which the person provides services at our request provided that such person follows the procedures for determining entitlement to indemnification and advancement of expenses set forth in the indemnification agreement. We believe that these bylaw provisions and indemnification agreements are necessary to attract and retain qualified persons as directors and officers.

The limitation of liability and indemnification provisions in our certificate of incorporation and bylaws may discourage stockholders from bringing a lawsuit against directors for breach of their fiduciary duties. They may also reduce the likelihood of derivative litigation against directors and officers, even though an action, if successful, might provide a benefit to us and our stockholders. Our results of operations and financial condition may be harmed to the extent we pay the costs of settlement and damage awards against directors and officers pursuant to these indemnification provisions.

Insofar as indemnification for liabilities arising under the Securities Act may be permitted to directors, officers or persons controlling us, we have been informed that, in the opinion of the SEC, such indemnification is against public policy as expressed in the Securities Act and is therefore unenforceable.

At present, there is no pending litigation or proceeding involving any of our directors or officers as to which indemnification is required or permitted, and we are not aware of any threatened litigation or proceeding that may result in a claim for indemnification.

Dissenters' Rights of Appraisal and Payment

Under the Delaware General Corporation Law, with certain exceptions, our stockholders will have appraisal rights in connection with a merger or consolidation of Forza XI, Inc. Pursuant to the Delaware General Corporation Law, stockholders who properly request and perfect appraisal rights in connection with such merger or consolidation will have the right to receive payment of the fair value of their shares as determined by the Delaware Court of Chancery.

Stockholders' Derivative Actions

Under the Delaware General Corporation Law, any of our stockholders may bring an action in our name to procure a judgment in our favor, also known as a derivative action, provided that the stockholder bringing the action is a holder of our shares at the time of the transaction to which the action relates or such stockholder's stock thereafter devolved by operation of law.

Transfer Agent and Registrar

The transfer agent and registrar for our common stock is Interwest Transfer Company, Inc.

Trading Symbol and Market

We intend to apply to list our common stock on the Nasdaq Capital Market under the symbol "FRZA."

SHARES ELIGIBLE FOR FUTURE SALE

If our stockholders sell substantial amounts of our common stock, including shares issued upon the exercise of outstanding options or warrants, in the public market following the offering, the market price of our common stock could decline. These sales also might make it more difficult for us to sell equity or equity related securities in the future at a time and price that we deem appropriate.

Upon completion of the offering, we will have outstanding an aggregate of shares of our common stock, assuming no exercise of the underwriters' option to purchase additional shares and no exercise of outstanding options based on an assumed initial public offering price of \$ per share, which is the midpoint of the estimated offering price range set forth on the cover page of this prospectus. Of these shares, all of the shares sold in the offering will be freely tradable without restriction or further registration under the Securities Act, unless the shares are purchased by "affiliates" as that term is defined in Rule 144 under the Securities Act.

Upon consummation of this offering, our existing stockholders will hold shares of common stock. The shares of common stock will be "restricted securities" as defined in Rule 144 unless we register such issuances. Pre-IPO shares are subject to a lock-up agreement and will not be distributed or transferred for a period of six months from the date of closing.

Rule 144

In general, under Rule 144 as in effect on the date of this prospectus, beginning 90 days after the completion of this offering, a person (or persons whose shares are required to be aggregated) who is an affiliate and who has beneficially owned our shares for at least six months is entitled to sell in any three-month period a number of shares that does not exceed the greater of:

- 1% of the number of shares of common stock then outstanding, which will equal approximately shares of common stock immediately after completion of this offering; or
- the average weekly trading volume in our shares on the applicable stock exchange during the four calendar weeks preceding the filing of a notice on Form 144 with respect to such a sale.

Sales by our affiliates under Rule 144 are also subject to manner of sale provisions and notice requirements and to the availability of current public information about us. An “affiliate” is a person that directly, or indirectly through one or more intermediaries, controls or is controlled by, or is under common control with an issuer.

Under Rule 144, a person (or persons whose shares are aggregated) who is not deemed to have been an affiliate of ours at any time during the 90 days preceding a sale, and who has beneficially owned the shares of common stock proposed to be sold for at least six months (including the holding period of any prior owner other than an affiliate), would be entitled to sell those shares subject only to availability of current public information about us, and after beneficially owning such shares for at least 12 months (including the holding period of any prior owner other than an affiliate), would be entitled to sell an unlimited number of such shares without restriction. To the extent that our affiliates sell their shares, other than pursuant to Rule 144 or a registration statement, the purchaser’s holding period for the purpose of affecting a sale under Rule 144 commences on the date of transfer from the affiliate.

Lock-Up Agreements

Pursuant to “lock-up” agreements, we, our executive officers and directors, and our sole stockholder prior to completion of this offering, have agreed, without the prior written consent of the representative not to directly or indirectly, offer to sell, sell, pledge or otherwise transfer or dispose of any of shares of (or enter into any transaction or device that is designed to, or could be expected to, result in the transfer or disposition by any person at any time in the future of) our common stock, enter into any swap or other derivatives transaction that transfers to another, in whole or in part, any of the economic benefits or risks of ownership of shares of our common stock, make any demand for or exercise any right or cause to be filed a registration statement, including any amendments thereto, with respect to the registration of any shares of common stock or securities convertible into or exercisable or exchangeable for common stock or any other securities of ours or publicly disclose the intention to do any of the foregoing, subject to customary exceptions, for a period of one year and six months in case of our sole stockholder after the date of this prospectus in the case of our directors, executive officers, and our sole stockholder, and six months with respect to us.

93

Equity Awards

In general, under Rule 701 of the Securities Act as currently in effect, any of our employees, consultants, or advisors who purchase shares of our common stock from us in connection with a compensatory stock or option plan or other written agreement is eligible to resell those shares 90 days after the effective date of the offering in reliance on Rule 144, but without compliance with some of the restrictions, including the holding period, contained in Rule 144.

Following the offering, we intend to file a registration statement on Form S-8 under the Securities Act covering approximately _____ shares of common stock issued or issuable upon the exercise of stock options, subject to outstanding options or reserved for issuance under our employee and director stock benefit plans. Accordingly, shares registered under the registration statement will, subject to Rule 144 provisions applicable to affiliates, be available for sale in the open market, except to the extent that the shares are subject to vesting restrictions or the contractual restrictions described above.

94

MATERIAL U.S. FEDERAL INCOME TAX CONSIDERATIONS FOR NON-U.S. HOLDERS OF OUR COMMON STOCK

The following is a summary of the material U.S. federal income tax consequences of the ownership and disposition of our common stock acquired in this offering by a “non-U.S. holder” (as defined below), but does not purport to be a complete analysis of all the potential tax considerations relating thereto. This summary is based upon the provisions of the United States Internal Revenue Code of 1986, as amended, or the Code, Treasury Regulations promulgated thereunder, administrative rulings and judicial decisions, all as of the date hereof. These authorities may be changed, possibly retroactively, so as to result in U.S. federal income tax consequences different from those set forth below. We have not sought, and do not intend to seek, any ruling from the Internal Revenue Service, or IRS, with respect to the statements made and the conclusions reached in the following summary, and there can be no assurance that the IRS or a court will agree with such statements and conclusions.

This summary also does not address the tax considerations arising under the laws of any state or local or non-U.S. jurisdiction or under U.S. federal gift and estate tax rules, or rising out of other non-income tax rules, except to the limited extent set forth below. In addition, this discussion does not address tax considerations applicable to an investor’s particular circumstances or to investors that may be subject to special tax rules, including, without limitation:

- banks, insurance companies, regulated investment companies, real estate investment trusts or other financial institutions;
- persons subject to the alternative minimum tax or the tax on net investment income;
- persons subject to special tax accounting rules as a result of any item of gross income with respect to our common stock being taken into account in an applicable financial statement;
- tax-exempt organizations or governmental organizations;
- pension plans and tax-qualified retirement plans;
- controlled foreign corporations, passive foreign investment companies and corporations that accumulate earnings to avoid U.S. federal income tax;
- partnerships or other entities or arrangements treated as partnership for U.S. federal income tax purposes (and investors therein);
- brokers or dealers in securities or currencies;
- traders in securities that elect to use a mark-to-market method of accounting for their securities holdings;

- persons that own, or are deemed to own, more than five percent of our capital stock (except to the extent specifically set forth below);
- certain former citizens or long-term residents of the United States;
- persons who hold our common stock as a position in a hedging transaction, “straddle,” “conversion transaction” or other risk reduction transaction or integrated investment;
- persons who hold or receive our common stock pursuant to the exercise of any option or otherwise as compensation;
- persons who do not hold our common stock as a capital asset within the meaning of Section 1221 of the Code (generally, property held for investment); and
- persons deemed to sell our common stock under the constructive sale provisions of the Code.

In addition, if a partnership, entity or arrangement classified as a partnership or flow-through entity for U.S. federal income tax purposes holds our common stock, the tax treatment of a partner generally will depend on the status of the partner and upon the activities of the partnership or other entity. A partner in a partnership or other such entity that will hold our common stock should consult his, her or its own tax advisor regarding the tax consequences of the ownership and disposition of our common stock through a partnership or other such entity, as applicable.

This summary is for informational purposes only and is not tax advice. Each non-U.S. holder is urged to consult its own tax advisor with respect to the application of the U.S. federal income tax laws to its particular situation, as well as any tax consequences of the purchase, ownership and disposition of our common stock arising under the U.S. federal gift or estate tax rules or under the laws of any state, local, non-U.S. or other taxing jurisdiction or under any applicable tax treaty.

Non-U.S. Holder Defined

For purposes of this discussion, a “non-U.S. holder” is a beneficial owner of our common stock that, for U.S. federal income tax purposes, is neither a “U.S. person” nor an entity (or arrangement) treated as a partnership. A “U.S. person” is any person that, for U.S. federal income tax purposes, is or is treated as any of the following:

- an individual who is a citizen or resident of the United States;
- a corporation or other entity taxable as a corporation created or organized in the United States or under the laws of the United States or any political subdivision thereof, or otherwise treated as such for U.S. federal income tax purposes;
- an estate whose income is subject to U.S. federal income tax regardless of its source; or
- a trust (x) whose administration is subject to the primary supervision of a U.S. court and that has one or more U.S. persons who have the authority to control all substantial decisions of the trust or (y) that has made a valid election under applicable Treasury Regulations to be treated as a U.S. person.

Distributions

As described in the section titled “Dividend Policy,” we have never declared or paid cash dividends on our common stock, and we do not anticipate paying any dividends on our common stock following the completion of this offering. However, if we do make distributions of cash or property on our common stock to non-U.S. holders, such distributions will constitute dividends for U.S. federal income tax purposes to the extent paid from our current or accumulated earnings and profits, as determined under U.S. federal income tax principles. To the extent those distributions exceed both our current and our accumulated earnings and profits, the excess will first constitute a return of capital and will reduce each non-U.S. holder’s adjusted tax basis in our common stock, but not below zero. Any additional excess will then be treated as capital gain from the sale of stock, as discussed under “Gain on Disposition of Common Stock.”

Subject to the discussions below on effectively connected income, and backup withholding and Compliance Act, or FATCA, withholding, any dividend paid to a non-U.S. holder generally will be subject to U.S. federal withholding tax either at a rate of 30% of the gross amount of the dividend or such lower rate as may be specified by an applicable income tax treaty between the United States and such non-U.S. holder’s country of residence. In order to receive a reduced treaty rate, such non-U.S. holder must provide the applicable withholding agent with an IRS Form W-8BEN or W-8BEN-E or other appropriate version of IRS Form W-8 certifying qualification for the reduced treaty rate. A non-U.S. holder of shares of our common stock eligible for a reduced rate of U.S. federal withholding tax pursuant to an income tax treaty may obtain a refund of any excess amounts withheld by filing an appropriate claim for refund with the IRS. If such non-U.S. holder holds our common stock through a financial institution or other agent acting on the non-U.S. holder’s behalf, the non-U.S. holder will be required to provide appropriate documentation to such agent, which then will be required to provide certification to the applicable withholding agent, either directly or through other intermediaries. Each non-U.S. holder should consult its own tax advisors regarding their entitlement to benefits under any applicable income tax treaty.

Dividends received by a non-U.S. holder that are treated as effectively connected with such non-U.S. holder’s conduct of a trade or business within the United States (and, if an applicable income tax treaty so provides, such non-U.S. holder maintains a permanent establishment or fixed base in the United States to which such dividends are attributable) are generally exempt from the 30% U.S. federal withholding tax, subject to the discussion below on backup withholding and FATCA withholding. To claim this exemption, a non-U.S. holder must provide the applicable withholding agent with a properly executed IRS Form W-8ECI or other applicable IRS Form W-8 properly certifying such exemption. Such effectively connected dividends, although not subject to U.S. federal withholding tax, are taxed at the same graduated rates applicable to U.S. persons, net of certain deductions and credits, subject to an applicable income tax treaty providing otherwise. In addition, if a non-U.S. holder is a corporation, dividends such non-U.S. holder receives that are effectively connected with its conduct of a U.S. trade or business may also be subject to a branch profits tax at a rate of 30% or such lower rate as may be specified by an applicable income tax treaty between the United States and such non-U.S. holder’s country of residence. Each non-U.S. holder should consult its own tax advisor regarding the tax consequences of the ownership and disposition of our common stock, including any applicable tax treaties that may provide for different rules.

Gain on Disposition of Common Stock

Subject to the discussion below regarding backup withholding and FATCA withholding, a non-U.S. holder generally will not be required to pay U.S. federal income tax on any gain realized upon the sale or other disposition of our common stock unless:

- the gain is effectively connected with such non-U.S. holder’s conduct of a U.S. trade or business (and, if an applicable income tax treaty so provides, such non-U.S. holder maintains a permanent establishment or fixed base in the United States to which such gain is attributable);

- such non-U.S. holder is an individual who is present in the United States for an aggregate 183 days or more during the taxable year in which the sale or disposition occurs and certain other conditions are met; or
- our common stock constitutes a United States real property interest, or USRPI, by reason of our status as a “United States real property holding corporation,” or USRPHC, for U.S. federal income tax purposes.

We believe that we are not currently and will not become a USRPHC for U.S. federal income tax purposes, and the remainder of this discussion so assumes. However, because the determination of whether we are a USRPHC depends on the fair market value of our U.S. real property interests relative to the fair market value of our U.S. and worldwide real property interests plus our other business assets, there can be no assurance that we will not become a USRPHC in the future. Even if we become a USRPHC, however, as long as our common stock is regularly traded on an established securities market, your common stock will be treated as U.S. real property interests only if you actually (directly or indirectly) or constructively hold more than 5% of such regularly traded common stock at any time during the shorter of the five-year period preceding your disposition of, or your holding period for, our common stock.

A non-U.S. holder described in the first bullet above will be required to pay U.S. federal income tax on the gain derived from the sale (net of certain deductions and credits) under regular graduated U.S. federal income tax rates. Such a non-U.S. holder that is a corporation may be subject to the branch profits tax at a 30% rate on a portion of its effectively connected earnings and profits for the taxable year that are attributable to such gain, as adjusted for certain items. A lower rate may be specified by an applicable income tax treaty.

A non-U.S. holder described in the second bullet above will be subject to tax at 30% (or such lower rate specified by an applicable income tax treaty) on the gain derived from the sale, which gain may be offset by U.S. source capital losses of such non-U.S. holder for the taxable year, provided such non-U.S. holder has timely filed U.S. federal income tax returns with respect to such losses.

Each non-U.S. holder should consult its own tax advisor regarding any applicable income tax or other treaties that may provide for different rules.

Information Reporting and Backup Withholding

Generally, we or an applicable withholding agent must report annually to the IRS the amount of dividends paid to a non-U.S. holder, such non-U.S. holder’s name and address, and the amount of tax withheld, if any. A similar report is sent to such non-U.S. holder. Pursuant to any applicable income tax treaty or other agreement, the IRS may make such report available to the tax authority in such non-U.S. holder’s country of residence.

Dividends paid by us (or our paying agent) to a non-U.S. holder may also be subject to backup withholding at a current rate of 24%.

Such information reporting and backup withholding requirements may be avoided, however, if such non-U.S. holder establishes an exemption by providing a properly executed, and applicable, IRS Form W-8, or otherwise establishes an exemption. Generally, such information reporting and backup withholding requirements will not apply to a non-U.S. holder where the transaction is effected outside the United States, through a non-U.S. office of a non-U.S. broker. Notwithstanding the foregoing, backup withholding and information reporting may apply, however, if the applicable withholding agent has actual knowledge, or reason to know, that such non-U.S. holder is a U.S. person.

Backup withholding is not an additional tax; rather, the U.S. federal income tax liability of persons subject to backup withholding will be reduced by the amount of tax withheld. If withholding results in an overpayment of taxes, a refund or credit may generally be obtained from the IRS, provided that the required information is furnished to the IRS in a timely manner.

Foreign Account Tax Compliance Act (FATCA)

Sections 1471 to 1474 of the Code, Treasury Regulations issued thereunder and related official IRS guidance, commonly referred to as FATCA, generally impose a U.S. federal withholding tax of 30% on dividends on our common stock paid to a “foreign financial institution” (as defined under FATCA, and which may include banks, traditional financial institutions, investment funds, and certain holding companies), unless such institution enters into an agreement with the U.S. Department of the Treasury to, among other things, identify accounts held by certain “specified United States persons” or “United States-owned foreign entities” (each as defined under FATCA), report annually substantial information about such accounts, and withhold on certain payments to non-compliant foreign financial institutions and certain other account holders. FATCA also generally imposes a U.S. federal withholding tax of 30% on dividends on our common stock paid to a “non-financial foreign entity” (as specially defined under FATCA), unless such entity provides identifying information regarding each direct or indirect “substantial United States owners” (as defined under FATCA), certifies that it does not have any substantial United States owners, or otherwise establishes an exemption. Accordingly, the institution or entity through which our common stock is held will affect the determination of whether such withholding is required.

The withholding obligations under FATCA generally apply to dividends on our common stock. Such withholding will apply regardless of whether the beneficial owner of the payment otherwise would be exempt from withholding pursuant to an applicable tax treaty with the United States, the Code, or other exemptions described above. Under certain circumstances, a non-U.S. holder might be eligible for refunds or credits of such taxes.

Under proposed regulations, FATCA withholding on payments of gross proceeds has been eliminated. These proposed regulations are subject to change.

An intergovernmental agreement between the United States and an applicable foreign country may modify the requirements described in this section. Prospective investors are encouraged to consult with their own tax advisors regarding the application of FATCA withholding to their investment in, and ownership and disposition of, our common stock.

The preceding discussion of U.S. federal tax considerations is for general information only. It is not tax advice to investors in their particular circumstances. Each prospective investor should consult its own tax advisor regarding the particular U.S. federal, state and local and non-U.S. tax consequences of purchasing, holding and disposing of our common stock, including the consequences of any proposed change in applicable laws.

UNDERWRITING

ThinkEquity LLC is acting as representative of the underwriters. Subject to the terms and conditions of an underwriting agreement between us and the representative, we have agreed to sell to each underwriter named below, and each underwriter named below has severally agreed to purchase, at the public offering price less the underwriting discounts set forth on the cover page of this prospectus, the number of shares of common stock listed next to its name in the following table:

Underwriters	Number of Shares
--------------	------------------

The underwriting agreement provides that the obligations of the underwriters to pay for and accept delivery of the shares of common stock offered by this prospectus are subject to various conditions and representations and warranties, including the approval of certain legal matters by their counsel and other conditions specified in the underwriting agreement. The shares of common stock are offered by the underwriters, subject to prior sale, when, as and if issued to and accepted by them. The underwriters reserve the right to withdraw, cancel or modify the offer to the public and to reject orders in whole or in part. The underwriters are obligated to take and pay for all of the shares of common stock offered by this prospectus if any such shares of common stock are taken, other than those shares of common stock covered by the over-allotment option described below.

We have agreed to indemnify the underwriters against specified liabilities, including liabilities under the Securities Act, and to contribute to payments the underwriters may be required to make in respect thereof.

Over-Allotment Option

We have granted a 45-day option to the representative of the underwriters to purchase up to additional shares of our common stock at a public offering price of \$ per share, solely to cover over-allotments, if any. The underwriters may exercise this option for 45 days from the date of this prospectus solely to cover sales of shares of common stock by the underwriters in excess of the total number of shares of common stock set forth in the table above. If any of these additional shares are purchased, the underwriters will offer the additional shares on the same terms as those on which the shares are being offered.

Discounts and Commissions

The underwriters propose initially to offer the shares of common stock to the public at the public offering price set forth on the cover page of this prospectus and to dealers at those prices less a concession not in excess of \$ per share of common stock. If all of the shares of common stock offered by us are not sold at the public offering price, the underwriters may change the offering price and other selling terms by means of a supplement to this prospectus.

The following table shows the public offering price, underwriting discounts and commissions and proceeds before expenses to us. The information assumes either no exercise or full exercise of the over-allotment option we granted to the representative of the underwriters.

	Per Share	Total Without Over- allotment Option	Total With Over- allotment Option
Public offering price	\$	\$	\$
Underwriting discount (7.5%)	\$	\$	\$
Proceeds, before expenses, to us	\$	\$	\$
Non-accountable expense allowance (1%)	\$	\$	\$

We have agreed to pay a non-accountable expense allowance to the representative of the underwriters equal to 1% of the gross proceeds received at the closing of the offering. We have paid an expense deposit of \$25,000 to the representative, which will be applied against the out-of-pocket accountable expenses that will be paid by us to the underwriters in connection with this offering, and will be reimbursed to us to the extent not actually incurred in compliance with FINRA Rule 5110(g)(4)(A).

We have also agreed to pay certain of the representatives expenses relating to the offering, including: (a) fees and expenses of the underwriter's legal counsel not to exceed \$125,000; (b) a \$29,500 cost associated with the underwriters use of Ipreo's book-building, prospectus tracking and compliance software for the offering; (c) \$10,000 for data services and communications expenses; (d) up to \$10,000 of underwriter's actual accountable "road show" expenses; (e) up to \$30,000 of underwriter's market making and trading, and clearing firm settlement expenses for the offering; (f) all fees, expenses and disbursements relating to background checks of the our officers, directors and affiliates in an amount not to exceed \$15,000 in the aggregate; and (g) the costs associated with bound volumes of the public offering materials as well as commemorative mementos and lucite tombstones, each of which is to be provided by us or our designee within a reasonable time after the closing of this offering in such quantities as the underwriter may reasonably request, in an amount not to exceed \$3,000.

Our total estimated expenses of the offering, including registration, filing and listing fees, printing fees and legal and accounting expenses, but excluding underwriting discounts and commissions, are approximately \$.

Representative's Warrants

Upon closing of this offering, we have agreed to issue to the representative as compensation warrants to purchase up to shares of common stock (5% of the aggregate number of shares of common stock sold in this offering, or the representative's warrants). The representative's warrants will be exercisable at a per share exercise price equal to 125% of the public offering price per share in this offering. The representative's warrants are exercisable at any time and from time to time, in whole or in part, during the four and one half year period commencing 180 days from the effective date of the registration statement of which this prospectus is a part.

The representative's warrants have been deemed compensation by FINRA and are therefore subject to a 180-day lock-up pursuant to Rule 5110(e)(1)(A) of FINRA. The representative (or permitted assignees under Rule 5110(e)(1)(A)) will not sell, transfer, assign, pledge, or hypothecate these warrants or the securities underlying these warrants, nor will they engage in any hedging, short sale, derivative, put, or call transaction that would result in the effective economic disposition of the warrants or the underlying securities for a period of 180 days from the effective date of the registration statement of which this prospectus is a part. In addition, the warrants provide for registration rights upon request, in certain cases. The sole demand registration right provided will not be greater than five years from the effective date of the registration statement in compliance with FINRA Rule 5110(g)(8)(C). The piggyback registration rights provided will not be greater than seven years from the effective date of the registration statement in compliance with FINRA Rule 5110(g)(8)(D). We will bear all fees and expenses attendant to registering the securities issuable on exercise of the warrants other than underwriting commissions incurred and payable by the holders. The exercise price and number of shares issuable upon exercise of the warrants may be adjusted in certain circumstances including in the event of a stock dividend or our recapitalization, reorganization, merger or consolidation. However, the warrant exercise price or underlying shares will not be adjusted for issuances of shares of common stock at a price below the warrant exercise price.

Lock-Up Agreements

Pursuant to "lock-up" agreements, we, our executive officers and directors, and our sole stockholder prior to completion of this offering, have agreed, without the prior written consent of the representative not to directly or indirectly, offer to sell, sell, pledge or otherwise transfer or dispose of any of shares of (or enter into any transaction or device that is designed to, or could be expected to, result in the transfer or disposition by any person at any time in the future of) our common stock, enter into any swap or other derivatives transaction that transfers to another, in whole or in part, any of the economic benefits or risks of ownership of shares of our common stock, make any demand for or exercise any right or cause to be filed a registration statement, including any amendments thereto, with respect to the registration of any shares of common stock or securities convertible into or exercisable or exchangeable for common stock or any other securities of ours or publicly disclose the intention to do any of the foregoing, subject to customary exceptions, for a period of one year and six months in case of our sole stockholder after the date of this prospectus in the case of our directors, executive officers, and our sole stockholder,

Right of First Refusal

Until twenty-four (24) months from the closing date of this offering, the representative will have an irrevocable right of first refusal, in its sole discretion, to act as sole investment banker, sole book-runner, and/or sole placement agent, at the representative's sole discretion, for each and every future public and private equity and debt offering, including all equity linked financings, during such twenty-four (24) month period, on terms customary to the representative. The representative will have the sole right to determine whether or not any other broker-dealer will have the right to participate in any such offering and the economic terms of any such participation. The representative will not have more than one opportunity to waive or terminate the right of first refusal in consideration of any payment or fee.

Discretionary Accounts

The underwriters do not intend to confirm sales of the shares of common stock offered hereby to any accounts over which they have discretionary authority.

Nasdaq Capital Market Listing

We intend to apply to have our common stock listed on the Nasdaq Capital Market under the symbol "FRZA."

Determination of Offering Price

The public offering price of the securities we are offering was negotiated between us and the underwriters. Factors considered in determining the public offering price of the shares include the history and prospects of the Company, the stage of development of our business, our business plans for the future and the extent to which they have been implemented, an assessment of our management, general conditions of the securities markets at the time of the offering and such other factors as were deemed relevant.

Other

From time to time, certain of the underwriters and/or their affiliates may in the future provide, various investment banking and other financial services for us for which they may receive customary fees. In the course of their businesses, the underwriters and their affiliates may actively trade our securities or loans for their own account or for the accounts of customers, and, accordingly, the underwriters and their affiliates may at any time hold long or short positions in such securities or loans. Except for services provided in connection with this offering, no underwriter has provided any investment banking or other financial services to us during the 180-day period preceding the date of this prospectus and we do not expect to retain any underwriter to perform any investment banking or other financial services for at least 90 days after the date of this prospectus.

Price Stabilization, Short Positions and Penalty Bids

In connection with this offering, the underwriters may engage in transactions that stabilize, maintain or otherwise affect the price of our common stock. Specifically, the underwriters may over-allot in connection with this offering by selling more shares than are set forth on the cover page of this prospectus. This creates a short position in our common stock for its own account. The short position may be either a covered short position or a naked short position. In a covered short position, the number of shares of common stock over-allotted by the underwriters is not greater than the number of shares of common stock that they may purchase in the over-allotment option. In a naked short position, the number of shares of common stock involved is greater than the number of shares common stock in the over-allotment option. To close out a short position, the underwriters may elect to exercise all or part of the over-allotment option. The underwriters may also elect to stabilize the price of our common stock or reduce any short position by bidding for, and purchasing, common stock in the open market.

The underwriters may also impose a penalty bid. This occurs when a particular underwriter or dealer repays selling concessions allowed to it for distributing shares of common stock in this offering because the underwriter repurchases the shares of common stock in stabilizing or short covering transactions.

Finally, the underwriters may bid for, and purchase, shares of our common stock in market making transactions, including "passive" market making transactions as described below.

These activities may stabilize or maintain the market price of our common stock at a price that is higher than the price that might otherwise exist in the absence of these activities. The underwriters are not required to engage in these activities, and may discontinue any of these activities at any time without notice. These transactions may be effected on the national securities exchange on which our shares of common stock are traded, in the over-the-counter market, or otherwise.

Indemnification

We have agreed to indemnify the underwriters against liabilities relating to this offering arising under the Securities Act and the Exchange Act, liabilities arising from breaches of some or all of the representations and warranties contained in the underwriting agreement, and to contribute to payments that the underwriters may be required to make for these liabilities.

Electronic Distribution

This prospectus in electronic format may be made available on websites or through other online services maintained by one or more of the underwriters, or by their affiliates. Other than this prospectus in electronic format, the information on any underwriter's website and any information contained in any other website maintained by an underwriter is not part of this prospectus or the registration statement of which this prospectus forms a part, has not been approved and/or endorsed by us or any underwriter in its capacity as underwriter, and should not be relied upon by investors.

Offer restrictions outside the United States

Other than in the United States, no action has been taken by us or the underwriters that would permit a public offering of the securities offered by this prospectus in any jurisdiction where action for that purpose is required. The securities offered by this prospectus may not be offered or sold, directly or indirectly, nor may this prospectus or any other offering material or advertisements in connection with the offer and sale of any such securities be distributed or published in any jurisdiction, except under circumstances that will result in compliance with the applicable rules and regulations of that jurisdiction. Persons into whose possession this prospectus comes are advised to inform themselves about and to observe any restrictions relating to the offering and the distribution of this prospectus. This prospectus does not constitute an offer to sell or a solicitation of an offer to buy any securities offered by this prospectus in any jurisdiction in which such an offer or a solicitation is unlawful.

Australia

This prospectus is not a disclosure document under Chapter 6D of the Australian Corporations Act, has not been lodged with the Australian Securities and Investments Commission and does not purport to include the information required of a disclosure document under Chapter 6D of the Australian Corporations Act. Accordingly, (i) the offer of the securities under this prospectus is only made to persons to whom it is lawful to offer the securities without disclosure under Chapter 6D of the Australian Corporations Act under one or more exemptions set out in section 708 of the Australian Corporations Act, (ii) this prospectus is made available in Australia only to those persons as set forth in clause (i) above, and (iii) the offeree must be sent a notice stating in substance that by accepting this offer, the offeree represents that the offeree is such a person as set forth in clause (i) above, and, unless permitted under the Australian Corporations Act, agrees not to sell or offer for sale within Australia any of the securities sold to the offeree within 12 months after its transfer to the offeree under this prospectus.

Canada

The shares of common stock may be sold only to purchasers purchasing, or deemed to be purchasing, as principal that are accredited investors, as defined in National Instrument 45-106 Prospectus Exemptions or subsection 73.3(1) of the Securities Act (Ontario), and are permitted clients, as defined in National Instrument 31-103 Registration Requirements, Exemptions and Ongoing Registrant Obligations. Any resale of the securities must be made in accordance with an exemption from, or in a transaction not subject to, the prospectus requirements of applicable securities laws.

102

Securities legislation in certain provinces or territories of Canada may provide a purchaser with remedies for rescission or damages if this prospectus (including any amendment thereto) contains a misrepresentation, provided that the remedies for rescission or damages are exercised by the purchaser within the time limit prescribed by the securities legislation of the purchaser's province or territory. The purchaser should refer to any applicable provisions of the securities legislation of the purchaser's province or territory for particulars of these rights or consult with a legal advisor.

China

The information in this document does not constitute a public offer of the securities, whether by way of sale or subscription, in the People's Republic of China (excluding, for purposes of this paragraph, Hong Kong Special Administrative Region, Macau Special Administrative Region and Taiwan). The securities may not be offered or sold directly or indirectly in the PRC to legal or natural persons other than directly to "qualified domestic institutional investors."

European Economic Area—Belgium, Germany, Luxembourg and Netherlands

The information in this document has been prepared on the basis that all offers of securities will be made pursuant to an exemption under the Directive 2003/71/EC ("Prospectus Directive"), as implemented in Member States of the European Economic Area (each, a "Relevant Member State"), from the requirement to produce a prospectus for offers of securities.

An offer to the public of securities has not been made, and may not be made, in a Relevant Member State except pursuant to one of the following exemptions under the Prospectus Directive as implemented in that Relevant Member State:

- to legal entities that are authorized or regulated to operate in the financial markets or, if not so authorized or regulated, whose corporate purpose is solely to invest in securities;
- to any legal entity that has two or more of (i) an average of at least 250 employees during its last fiscal year; (ii) a total balance sheet of more than €43,000,000 (as shown on its last annual unconsolidated or consolidated financial statements) and (iii) an annual net turnover of more than €50,000,000 (as shown on its last annual unconsolidated or consolidated financial statements);
- to fewer than 100 natural or legal persons (other than qualified investors within the meaning of Article 2(1)(e) of the Prospectus Directive) subject to obtaining the prior consent of the Company or any underwriter for any such offer; or
- in any other circumstances falling within Article 3(2) of the Prospectus Directive, provided that no such offer of securities shall result in a requirement for the publication by the Company of a prospectus pursuant to Article 3 of the Prospectus Directive.

France

This document is not being distributed in the context of a public offering of financial securities (offre au public de titres financiers) in France within the meaning of Article L.411-1 of the French Monetary and Financial Code (Code Monétaire et Financier) and Articles 211-1 et seq. of the General Regulation of the French Autorité des marchés financiers ("AMF"). The securities have not been offered or sold and will not be offered or sold, directly or indirectly, to the public in France.

This document and any other offering material relating to the securities have not been, and will not be, submitted to the AMF for approval in France and, accordingly, may not be distributed or caused to be distributed, directly or indirectly, to the public in France.

Such offers, sales and distributions have been and shall only be made in France to (i) qualified investors (investisseurs qualifiés) acting for their own account, as defined in and in accordance with Articles L.411-2-II-2° and D.411-1 to D.411-3, D.744-1, D.754-1 ;and D.764-1 of the French Monetary and Financial Code and any implementing regulation and/or (ii) a restricted number of non-qualified investors (cercle restreint d'investisseurs) acting for their own account, as defined in and in accordance with Articles L.411-2-II-2° and D.411-4, D.744-1, D.754-1; and D.764-1 of the French Monetary and Financial Code and any implementing regulation.

103

Pursuant to Article 211-3 of the General Regulation of the AMF, investors in France are informed that the securities cannot be distributed (directly or indirectly) to the public by the investors otherwise than in accordance with Articles L.411-1, L.411-2, L.412-1 and L.621-8 to L.621-8-3 of the French Monetary and Financial Code.

Ireland

The information in this document does not constitute a prospectus under any Irish laws or regulations and this document has not been filed with or approved by any Irish regulatory authority as the information has not been prepared in the context of a public offering of securities in Ireland within the meaning of the Irish Prospectus (Directive 2003/71/EC) Regulations 2005 (the "Prospectus Regulations"). The securities have not been offered or sold, and will not be offered, sold or delivered directly or indirectly in Ireland by way of a public offering, except to (i) qualified investors as defined in Regulation 2(1) of the Prospectus Regulations and (ii) fewer than 100 natural or legal persons who are not qualified investors.

Israel

The securities offered by this prospectus have not been approved or disapproved by the Israeli Securities Authority (the ISA), nor have such securities been registered for sale in Israel. The shares may not be offered or sold, directly or indirectly, to the public in Israel, absent the publication of a prospectus. The ISA has not issued permits, approvals or licenses in connection with the offering or publishing the prospectus; nor has it authenticated the details included herein, confirmed their reliability or completeness, or rendered an opinion as to the quality of the securities being offered. Any resale in Israel, directly or indirectly, to the public of the securities offered by this prospectus is subject to restrictions on transferability and must be effected only in compliance with the Israeli securities laws and regulations.

Italy

The offering of the securities in the Republic of Italy has not been authorized by the Italian Securities and Exchange Commission (Commissione Nazionale per le Società e la Borsa, or "CONSOB") pursuant to the Italian securities legislation and, accordingly, no offering material relating to the securities may be distributed in Italy and such securities may not be offered or sold in Italy in a public offer within the meaning of Article 1.1(t) of Legislative Decree No. 58 of 24 February 1998 ("Decree No. 58"), other than:

- to Italian qualified investors, as defined in Article 100 of Decree no.58 by reference to Article 34-ter of CONSOB Regulation no. 11971 of 14 May 1999 ("Regulation no. 11971") as amended ("Qualified Investors"); and
- in other circumstances that are exempt from the rules on public offer pursuant to Article 100 of Decree No. 58 and Article 34-ter of Regulation No. 11971 as amended.
- Any offer, sale or delivery of the securities or distribution of any offer document relating to the securities in Italy (excluding placements where a Qualified Investor solicits an offer from the issuer) under the paragraphs above must be:
- made by investment firms, banks or financial intermediaries permitted to conduct such activities in Italy in accordance with Legislative Decree No. 385 of 1 September 1993 (as amended), Decree No. 58, CONSOB Regulation No. 16190 of 29 October 2007 and any other applicable laws; and
- in compliance with all relevant Italian securities, tax and exchange controls and any other applicable laws.

Any subsequent distribution of the securities in Italy must be made in compliance with the public offer and prospectus requirement rules provided under Decree No. 58 and the Regulation No. 11971 as amended, unless an exception from those rules applies. Failure to comply with such rules may result in the sale of such securities being declared null and void and in the liability of the entity transferring the securities for any damages suffered by the investors.

Japan

The securities have not been and will not be registered under Article 4, paragraph 1 of the Financial Instruments and Exchange Law of Japan (Law No. 25 of 1948), as amended (the "FIEL") pursuant to an exemption from the registration requirements applicable to a private placement of securities to Qualified Institutional Investors (as defined in and in accordance with Article 2, paragraph 3 of the FIEL and the regulations promulgated thereunder). Accordingly, the securities may not be offered or sold, directly or indirectly, in Japan or to, or for the benefit of, any resident of Japan other than Qualified Institutional Investors. Any Qualified Institutional Investor who acquires securities may not resell them to any person in Japan that is not a Qualified Institutional Investor, and acquisition by any such person of securities is conditional upon the execution of an agreement to that effect.

Portugal

This document is not being distributed in the context of a public offer of financial securities (oferta pública de valores mobiliários) in Portugal, within the meaning of Article 109 of the Portuguese Securities Code (Código dos Valores Mobiliários). The securities have not been offered or sold and will not be offered or sold, directly or indirectly, to the public in Portugal. This document and any other offering material relating to the securities have not been, and will not be, submitted to the Portuguese Securities Market Commission (Comissãõ do Mercado de Valores Mobiliários) for approval in Portugal and, accordingly, may not be distributed or caused to be distributed, directly or indirectly, to the public in Portugal, other than under circumstances that are deemed not to qualify as a public offer under the Portuguese Securities Code. Such offers, sales and distributions of securities in Portugal are limited to persons who are "qualified investors" (as defined in the Portuguese Securities Code). Only such investors may receive this document and they may not distribute it or the information contained in it to any other person.

Sweden

This document has not been, and will not be, registered with or approved by Finansinspektionen (the Swedish Financial Supervisory Authority). Accordingly, this document may not be made available, nor may the securities be offered for sale in Sweden, other than under circumstances that are deemed not to require a prospectus under the Swedish Financial Instruments Trading Act (1991:980) (Sw. lag (1991:980) om handel med finansiella instrument). Any offering of securities in Sweden is limited to persons who are "qualified investors" (as defined in the Financial Instruments Trading Act). Only such investors may receive this document and they may not distribute it or the information contained in it to any other person.

Switzerland

The securities may not be publicly offered in Switzerland and will not be listed on the SIX Swiss Exchange ("SIX") or on any other stock exchange or regulated trading facility in Switzerland. This document has been prepared without regard to the disclosure standards for issuance prospectuses under art. 652a or art. 1156 of the Swiss Code of Obligations or the disclosure standards for listing prospectuses under art. 27 ff. of the SIX Listing Rules or the listing rules of any other stock exchange or regulated trading facility in Switzerland. Neither this document nor any other offering material relating to the securities may be publicly distributed or otherwise made publicly available in Switzerland.

Neither this document nor any other offering material relating to the securities have been or will be filed with or approved by any Swiss regulatory authority. In particular, this document will not be filed with, and the offer of securities will not be supervised by, the Swiss Financial Market Supervisory Authority (FINMA).

This document is personal to the recipient only and not for general circulation in Switzerland.

United Kingdom

Neither the information in this document nor any other document relating to the offer has been delivered for approval to the Financial Services Authority in the United Kingdom and no prospectus (within the meaning of section 85 of the Financial Services and Markets Act 2000, as amended ("FSMA")) has been published or is intended to be published in respect of the securities. This document is issued on a confidential basis to "qualified investors" (within the meaning of section 86(7) of FSMA) in the United Kingdom, and the securities may not be offered or sold in the United Kingdom by means of this document, any accompanying letter or any other document, except in circumstances which do not require the publication of a prospectus pursuant to section 86(1) FSMA. This document should not be distributed, published or reproduced, in whole or in part, nor may its contents be disclosed by recipients to any other person in the United Kingdom.

Any invitation or inducement to engage in investment activity (within the meaning of section 21 of FSMA) received in connection with the issue or sale of the securities has only been communicated or caused to be communicated and will only be communicated or caused to be communicated in the United Kingdom in circumstances in which section 21(1) of FSMA does not apply to the Company.

In the United Kingdom, this document is being distributed only to, and is directed at, persons (i) who have professional experience in matters relating to investments falling within Article 19(5) (investment professionals) of the Financial Services and Markets Act 2000 (Financial Promotions) Order 2005 (“FPO”), (ii) who fall within the categories of persons referred to in Article 49(2)(a) to (d) (high net worth companies, unincorporated associations, etc.) of the FPO or (iii) to whom it may otherwise be lawfully communicated (together “relevant persons”). The investments to which this document relates are available only to, and any invitation, offer or agreement to purchase will be engaged in only with, relevant persons. Any person who is not a relevant person should not act or rely on this document or any of its contents.

Pursuant to section 3A.3 of National Instrument 33-105 Underwriting Conflicts, or NI 33-105, the underwriters are not required to comply with the disclosure requirements of NI 33-105 regarding underwriter conflicts of interest in connection with this offering.

LEGAL MATTERS

The validity of the securities being offered by this prospectus will be passed upon for us by Blank Rome LLP, New York, New York. Sichenzia Ross FERENCE LLP is acting as counsel for the underwriters.

EXPERTS

Grassi & Co., CPAs, P.C. (“Grassi”), independent registered public accounting firm, has audited our financial statements at December 31, 2021 and for the period from inception (October 15, 2021) through December 31, 2021, as set forth in their report. We have included our financial statements in the prospectus and elsewhere in the registration statement in reliance on Grassi’s report, given on their authority as experts in accounting and auditing.

WHERE YOU CAN FIND ADDITIONAL INFORMATION

We have filed with the SEC a registration statement on Form S-1 under the Securities Act with respect to the shares of our common stock offered by this prospectus. This prospectus, which constitutes a part of the registration statement, does not contain all of the information set forth in the registration statement, as permitted by the rules and regulations of the SEC. For further information with respect to us and our common stock, we refer you to the registration statement, including the exhibits filed as a part of the registration statement. Statements contained in this prospectus concerning the contents of any contract or any other document are not necessarily complete. If a contract or document has been filed as an exhibit to the registration statement, please see the copy of the contract or document that has been filed. Each statement in this prospectus relating to a contract or document filed as an exhibit is qualified in all respects by the filed exhibit. The SEC also maintains an Internet website that contains the registration statement of which this prospectus forms a part, as well as the exhibits thereto. These documents, along with future reports, proxy statements and other information about us, are available at the SEC’s website, www.sec.gov.

As a result of this offering, we will become subject to the information and reporting requirements of the Exchange Act, as amended, and, in accordance with this law, will file periodic reports, proxy statements and other information with the SEC. These periodic reports, proxy statements and other information will be available at the SEC’s website, www.sec.gov. We also maintain a website at www.inhibikase.com. Upon the completion of this offering, you may access these materials free of charge as soon as reasonably practicable after they are electronically filed with, or furnished to, the SEC. Information contained on our website is not a part of this prospectus, and the inclusion of our website address in this prospectus is an inactive textual reference only.

As a result of this offering, we will become subject to the information and reporting requirements of the Exchange Act, as amended, and, in accordance with this law, will file periodic reports, proxy statements and other information with the SEC. These periodic reports, proxy statements and other information will be available at the SEC’s website, www.sec.gov. We also maintain a website www.forzax1.com. Upon the completion of this offering, you may access these materials free of charge as soon as reasonably practicable after they are electronically filed with, or furnished to, the SEC. Information contained on our website is not a part of this prospectus, and the inclusion of our website address in this prospectus is an inactive textual reference only.

DISCLOSURE OF COMMISSION POSITION ON INDEMNIFICATION FOR SECURITIES ACT LIABILITIES

Insofar as indemnification for liabilities arising under the Securities Act may be permitted to our directors, officers, and controlling persons, we have been informed that in the opinion of the SEC this indemnification is against public policy as expressed in the Securities Act and is therefore unenforceable.

INDEX TO AUDITED INTERIM FINANCIAL STATEMENTS

	Page
Audited Financial Statements of Forza X1, Inc.:	
REPORT OF INDEPENDENT REGISTERED PUBLIC ACCOUNTING FIRM	F-2
AUDITED FINANCIAL STATEMENTS:	
BALANCE SHEET AT DECEMBER 31, 2021	F-3
STATEMENT OF OPERATIONS FOR THE PERIOD FROM INCEPTION (OCTOBER 15, 2021) THROUGH DECEMBER 31, 2021	F-4
STATEMENT OF STOCKHOLDER’S EQUITY FOR THE PERIOD FROM INCEPTION (OCTOBER 15, 2021) THROUGH DECEMBER 31, 2021	F-5
STATEMENT OF CASH FLOWS FOR THE PERIOD FROM INCEPTION (OCTOBER 15, 2021) THROUGH DECEMBER 31, 2021	F-6
NOTES TO FINANCIAL STATEMENTS	F-7

REPORT OF INDEPENDENT REGISTERED PUBLIC ACCOUNTING FIRM

To The Board of Directors and the Stockholder of
Forza X1, Inc.
Fort Pierce, Florida

Opinion on the Financial Statement

We have audited the accompanying financial statements of Forza X1, Inc. (the "Company"), which comprise the balance sheet at December 31, 2021, and the related statements of operations, stockholder's equity and cash flows for the period from inception (October 15, 2021) through December 31, 2021, and the related notes to the financial statements. In our opinion, the financial statements present fairly, in all material respects, the financial position of the Company at December 31, 2021 and the results of its operations and its cash flows for the period from inception (October 15, 2021) through December 31, 2021, in conformity with accounting principles generally accepted in the United States of America.

Going Concern

The accompanying financial statements have been prepared assuming that Forza X1, Inc., will continue as a going concern. As discussed in Note 2 to the financial statements, the Company's operating loss and negative cash from operations raise substantial doubt about its ability to continue as a going concern. Management's evaluation of the events and conditions, and management's plans regarding those matters, are also described in Note 2. The financial statements do not include any adjustments that might result from the outcome of this uncertainty.

Basis for Opinion

These financial statements are the responsibility of the Company's management. Our responsibility is to express an opinion on the Company's financial statements based on our audit. We are a public accounting firm registered with the Public Company Accounting Oversight Board (United States) (PCAOB) and are required to be independent with respect to the Company in accordance with the U.S. federal securities laws and the applicable rules and regulations of the Securities and Exchange Commission and the PCAOB.

We conducted our audit in accordance with the standards of the PCAOB and in accordance with auditing standards generally accepted in the United States of America. Those standards require that we plan and perform the audit to obtain reasonable assurance about whether the financial statements are free of material misstatement, whether due to error or fraud. The Company is not required to have, nor were we engaged to perform, an audit of its internal control over financial reporting. As part of our audit, we are required to obtain an understanding of internal control over financial reporting, but not for the purpose of expressing an opinion on the effectiveness of the Company's internal control over financial reporting. Accordingly, we express no such opinion.

Our audit included performing procedures to assess the risks of material misstatement of the financial statements, whether due to error or fraud, and performing procedures that respond to those risks. Such procedures included examining, on a test basis, evidence regarding the amounts and disclosures in the financial statements. Our audit also included evaluating the accounting principles used and significant estimates made by management, as well as evaluating the overall presentation of the financial statements. We believe that our audit provides a reasonable basis for our opinion.

/s/ GRASSI & CO., CPAs, P.C.

We have served as the Company's auditor since 2021.

Jericho, New York
February 2, 2022

FORZA X1, INC.
Balance Sheet

December 31,
2021

ASSETS	
Current Assets:	
Cash and cash equivalents	\$ 1,803,285
Prepaid expenses and other current assets	88,477
Total Current Assets	<u>1,891,762</u>
Deferred offering costs	105,500
Property and equipment, net	235,565
Total Assets	<u>\$ 2,232,827</u>
LIABILITIES AND STOCKHOLDER'S EQUITY	
Current Liabilities:	
Accounts payable	\$ 13,333
Accrued liabilities	35,128
Due to parent	596,917
Total Current Liabilities	<u>645,378</u>
Total Liabilities	<u>645,378</u>
Commitments and contingencies (Note 4)	
Stockholder's Equity:	
Common stock: 25,000,000 authorized; \$0.001 par value; 6,500,000 shares issued and outstanding	6,500
Additional paid-in capital	1,993,500
Accumulated deficit	(412,551)
Total Stockholder's Equity	<u>1,587,449</u>
Total Liabilities and Stockholder's Equity	<u>\$ 2,232,827</u>

See accompanying notes to financial statements

FORZA X1, INC.
Statement of Operations

	Inception (October 15, 2021) through December 31, 2021
Net sales	\$ —
Cost of products sold	—
Gross profit	<u>—</u>
Operating expenses:	
Selling, general and administrative	40,761
Salaries and wages	41,189
Research and development	211,111
Professional fees	40,259
Depreciation	3,208
Total operating expenses	<u>336,528</u>
Loss from operations	(336,528)
Other (expense) income:	
Interest expense	(15,771)
Loss on disposal of assets	(190,252)
Gain from insurance recovery	130,000
Total other (expenses)	<u>(76,023)</u>
Net loss	<u>\$ (412,551)</u>
Basic and diluted (loss) per common share	<u>\$ (0.06)</u>
Weighted average common shares outstanding basic and diluted	<u>6,500,000</u>

See accompanying notes to financial statements

FORZA X1, INC.
Statement of Stockholder's Equity

For the Period From Inception (October 15, 2021) through December 31, 2021

	Common Stock		Additional Paid-in Capital	(Accumulated Deficit)	Total Stockholder's Equity
	Shares	Amount			
Beginning, October 15, 2021	—	\$ —	\$ —	\$ —	\$ —
Capital contributions from parent	6,500,000	6,500	1,993,500	—	2,000,000
Net loss	—	—	—	(412,551)	(412,551)
Balance, December 31, 2021	<u>6,500,000</u>	<u>\$ 6,500</u>	<u>\$ 1,993,500</u>	<u>\$ (412,551)</u>	<u>\$ 1,587,449</u>

See accompanying notes to financial statement

FORZA X1, INC.
Statement of Cash Flows

		Inception (October 15, 2021) through December 31,
		2021
Cash Flows From Operating Activities		
Net loss	\$	(412,551)
Adjustments to reconcile net loss:		
Depreciation		3,208
Loss on disposal of asset		190,252
Changes in operating assets and liabilities:		
Prepaid expenses and other current assets		(88,477)
Accounts payable		13,333
Accrued liabilities		35,128
Net cash used in operating activities		(259,107)
Cash Flows From Investing Activities		
Purchase of property and equipment		(429,025)
Net cash used in investing activities		(429,025)
Cash Flows From Financing Activities		
Deferred offering costs		(105,500)
Capital contributions from parent		2,000,000
Repayments of advances from parent		(398,630)
Advances from parent		995,547
Net cash provided by financing activities		2,491,417
Net change in cash and cash equivalents		1,803,285
Cash and cash equivalents at beginning of period		—
Cash and cash equivalents at end of period	\$	1,803,285

See accompanying notes to financial statements

FORZA X1, INC.
NOTES TO FINANCIAL STATEMENTS
DECEMBER 31, 2021

1. Significant Accounting Policies

Organization

Forza X1, Inc. (“Forza”, “FX1”, “Forza X1” “we”, “us or the “Company”) is a wholly owned subsidiary of Twin Vee PowerCats, Co. (“Parent”). On October 15, 2021, Electra Power Sports, Inc., a wholly owned subsidiary of Twin Vee PowerCats,Co., was incorporated in the state of Delaware. On October 29, 2021, the Company filed a Certificate of Amendment and changed the company name to Forza X1, Inc.

Prior to Forza X1 inception on October 15, 2021, Twin Vee PowerCats, Co. dedicated resources to designing and building prototype electric boats. These resources and expenditures were segregated in Twin Vee PowerCats, Co’s financial statements and have been included in the financial statements of Forza for the period from inception, October 15, 2021, through December 31, 2021. Forza has a December 31st fiscal year-end.

Use of Estimates

The preparation of financial statements in conformity with accounting principles generally accepted in the United States “U.S. GAAP” required management to make estimates and assumptions that affect the amounts reported in the financial statements. Actual results could differ from those estimates. Included in those estimates are assumptions about useful life of fixed assets.

Cash and Cash Equivalents

Cash and cash equivalents include all highly liquid investments with original maturities of three months or less at the time of purchase. On December 31, 2021, the Company had \$1,742,019 in cash equivalents.

Property and Equipment

Property and equipment are stated at cost. Depreciation is provided using the straight-line method over the estimated useful lives of the related assets. The estimated useful lives of property and equipment range from three to seven years. Upon sale or retirement, the cost and related accumulated depreciation is eliminated from their respective accounts, and the resulting gain or loss is included in results of operations. Repairs and maintenance charges, which do not increase the useful lives of the assets, are charged to operations as incurred.

Impairment of Long-lived Assets

Management assesses the recoverability of its long-lived assets when indicators of impairment are present. If such indicators are present, recoverability of these assets is determined by comparing the undiscounted net cash flows estimated to result from those assets over the remaining life to the assets’ net carrying amounts. If the estimated undiscounted net cash flows are less than the net carrying amount, the assets would be adjusted to their fair value, based on appraisal or the present value of the undiscounted net cash flows.

Research and Development

Research and development costs are expensed when incurred. Such costs approximated \$211,111 for the period from inception (October 15, 2021) through December 31, 2021.

Advertising Costs

Advertising and marketing costs are expensed as incurred. For the period from inception (October 15, 2021) through December 31, 2021, advertising and marketing costs incurred by the Company totaled \$7,130, and are included in selling, general and administrative expenses in the accompanying statements of operations.

FORZA X1, INC.
NOTES TO FINANCIAL STATEMENTS
DECEMBER 31, 2021

Income Taxes

The Company is a C Corporation under the Internal Revenue Code and a similar section of the state code.

All income tax amounts reflect the use of the liability method under accounting for income taxes. Income taxes are provided for the tax effects of transactions reported in the financial statements and consist of taxes currently due plus deferred taxes arising primarily from differences between financial and tax reporting purposes.

Deferred income taxes, net of appropriate valuation allowances, are determined using the tax rates expected to be in effect when the taxes are actually paid. Valuation allowances are recorded against deferred tax assets when it is more likely than not that such assets will not be realized. When an uncertain tax position meets the more likely than not recognition threshold, the position is measured to determine the amount of benefit or expense to recognize in the financial statements.

In accordance with U.S GAAP, the Company follows the guidance in FASB ASC Topic 740, Accounting for Uncertainty in Income Taxes. At December 31, 2021, the Company does not believe it has any uncertain tax positions that would require either recognition or disclosure in the accompanying financial statements.

The Company's income tax returns are subject to review and examination by federal, state and local governmental authorities.

Recent Accounting Pronouncements

All newly issued accounting pronouncements not yet effective have been deemed either immaterial or not applicable.

2. Going Concern

Since inception (October 15, 2021), the Company has incurred net operating losses and used cash in operations. For the period from inception (October 15, 2021) through December 31, 2021, the Company has incurred a net loss of \$412,551 and used cash in operations of \$259,107. Losses have principally occurred as a result of the research and development efforts coupled with no operating revenue.

Without raising capital, there is a substantial doubt about the Company's ability to continue as a going concern. The accompanying financial statements have been prepared assuming that the Company will continue as a going concern. A successful transition to attaining profitable operations is dependent upon achieving a level of positive cash flows adequate to support the Company's cost structure.

The accompanying financial statements do not include any adjustments that might be required should the Company be unable to continue as a going concern.

3. Property and Equipment

At December 31, 2021, property and equipment consisted of the following:

	December 31, 2021
Building – construction in progress	\$ 53,250
Computer hardware and software	8,998
Prototype	142,526
Molds and fixtures	34,000
	<u>238,773</u>
Less accumulated depreciation	(3,208)
	<u>\$ 235,565</u>

Depreciation expense of property and equipment for the period of inception (October 15, 2021) through December 31, 2021, was \$3,208.

4. Commitments and Contingencies

Covid-19

The COVID-19 outbreak in the United States has caused business disruptions through mandated and voluntary closings of multiple industries. While disruption is currently expected to be temporary, there is considerable uncertainty regarding the duration of the closings. The extent to which COVID-19 impacts future results, which are highly uncertain and cannot be predicted, including new information which may emerge concerning the severity of the coronavirus and the actions to contain it or treat its impact, among others. At this time, the Company cannot estimate with meaningful precision the potential impact to its financial and operational results.

FORZA X1, INC.
NOTES TO FINANCIAL STATEMENTS
DECEMBER 31, 2021

5. Related Party Transaction

At December 31, 2021, the Company had \$596,917 due to Twin Vee PowerCats, Co., our parent company ("Parent"). Parent funded our working capital needs, primarily for prototyping, consulting services, rent, interest and payroll, prior to their \$2,000,000 investment. Associated with amounts advanced and due to Parent, during the period of inception (October 15, 201) through December 31, 2021, we recorded interest expense of \$15,771 based on a rate of 6% interest on our average monthly balance.

For the period of inception (October 15, 201) through December 31, 2021, we recorded management fees of \$15,000, pursuant to a management agreement with Twin Vee PowerCats, Co., dated October 2021 for various management services. The agreement provides for a monthly \$5,000 management fee associated with the use of shared management resources, has a term of one year and will expire on September 30, 2022.

For the period of inception (October 15, 201) through December 31, 2021, we recorded rent expense of \$9,795 associated with our month- to- month arrangement to utilize certain space at our parent company's facility. The Company incurs \$850 per month for rent expense for approximately 1,000 square feet. While our Corporate headquarters is located at our Parent location, all of our employees and consultants work remotely, and the use of our Parent company's facilities is limited.

6. Gain from Insurance Recovery

The Company experienced a thermal event on the electric boat prototype rendering it unusable for further testing. The Company recorded a loss on disposal of asset from fire of \$190,252 and gain from insurance recovery of \$130,000.

7. Subsequent Events

The Company has evaluated all event or transactions that occurred after December 31,2021 through February 2, 2022, which is the date that the financial statements were available to be issued. During this period, there were no material subsequent events requiring recognition or disclosure.

Shares of Common Stock



Forza X1, Inc.

PRELIMINARY PROSPECTUS

ThinkEquity

, 2022

Through and including _____, 2022 (the 25th day after the date of this offering), all dealers effecting transactions in these securities, whether or not participating in this offering, may be required to deliver a prospectus. This is in addition to a dealer's obligation to deliver a prospectus when acting as an underwriter and with respect to an unsold allotment or subscription.

PART II

INFORMATION NOT REQUIRED IN THE PROSPECTUS

Item 13. Other Expenses of Issuance and Distribution

The following table sets forth the expenses to be incurred in connection with the offering described in this Registration Statement, other than underwriting discounts and commissions, all of which will be paid by us. All amounts are estimates except the SEC's registration fee, the Financial Industry Regulatory Authority, Inc.'s filing fee and the Nasdaq listing fee.

	Amount to be Paid
SEC Registration Fee	\$ 2,832
FINRA filing fee	5,083
Nasdaq listing fee	45,000
Printing and engraving expenses	35,000
Legal fees and expenses	700,000
Accounting fees and expenses	150,000
Transfer agent and registrar fees	5,000
Miscellaneous expenses	57,085
Total	\$ 1,000,000

Item 14. Indemnification of Directors and Officers

Section 145 of the Delaware General Corporation Law empowers a corporation to indemnify its directors and officers and to purchase insurance with respect to liability arising out of their capacity or status as directors and officers, provided that the person acted in good faith and in a manner the person reasonably believed to be in our best interests, and, with respect to any criminal action, had no reasonable cause to believe the person's actions were unlawful. The Delaware General Corporation Law further provides that the indemnification permitted thereunder shall not be deemed exclusive of any other rights to which the directors and officers may be entitled under the corporation's bylaws, any agreement, a vote of stockholders or otherwise. The certificate of incorporation of the registrant to be in effect upon the completion of this offering provides for the indemnification of the registrant's directors and officers to the fullest extent permitted under the Delaware General Corporation Law. In addition, the bylaws of the registrant to be in effect upon the completion of this offering require the registrant to fully indemnify any person who was or is a party or is threatened to be made a party to any threatened, pending or completed action, suit or proceeding (whether civil, criminal, administrative or investigative) by reason of the fact that such person is or was a director or officer of the registrant, or is or was a director or officer of the registrant serving at the registrant's request as a director, officer, employee or agent of another corporation, partnership, joint venture, trust or other enterprise, against expenses (including attorney's fees), judgments, fines and amounts paid in settlement actually and reasonably incurred by such person in connection with such action, suit or proceeding, to the fullest extent permitted by applicable law.

Section 102(b)(7) of the Delaware General Corporation Law permits a corporation to provide in its certificate of incorporation that a director of the corporation shall not be personally liable to the corporation or its stockholders for monetary damages for breach of fiduciary duty as a director, except (i) for any breach of the director's duty of loyalty to the corporation or its stockholders; (ii) for acts or omissions not in good faith or which involve intentional misconduct or a knowing violation of law; (iii) for payments of unlawful dividends or unlawful stock repurchases or redemptions; or (iv) for any transaction from which the director derived an improper personal benefit. The registrant's certificate of incorporation to be in effect upon the completion of this offering provides that the registrant's directors shall not be personally liable to it or its stockholders for monetary damages for breach of fiduciary duty as a director and that if the Delaware General Corporation Law is amended to authorize corporate action further eliminating or limiting the personal liability of directors, then the liability of the registrant's directors shall be eliminated or limited to the fullest extent permitted by the Delaware General Corporation Law, as so amended.

As permitted by the Delaware General Corporation Law, the registrant intends to enter into separate indemnification agreements with each of the registrant's directors and certain of the registrant's officers which require the registrant, among other things, to indemnify them against certain liabilities which may arise by reason of their status as directors, officers or certain other employees.

The registrant expects to obtain and maintain insurance policies under which its directors and officers are insured, within the limits and subject to the limitations of those policies, against certain expenses in connection with the defense of, and certain liabilities which might be imposed as a result of, actions, suits or proceedings to which they are parties by reason of being or having been directors or officers. The coverage provided by these policies may apply whether or not the registrant would have the power to indemnify such person against such liability under the provisions of the Delaware General Corporation Law.

These indemnification provisions and the indemnification agreements entered into between the registrant and the registrant's officers and directors may be sufficiently broad to permit indemnification of the registrant's officers and directors for liabilities (including reimbursement of expenses incurred) arising under the Securities Act of 1933, as amended.

The proposed form of underwriting agreement between the registrant and the representative of the underwriters to be filed as Exhibit 1.1 to this registration statement provides for the indemnification by the underwriters of the registrant's directors and officers and certain controlling persons against specified liabilities, including liabilities under the Securities Act with respect to information provided by the underwriters specifically for inclusion in the registration statement.

Item 15. Recent Sales of Unregistered Securities

None.

Item 16. Exhibit and Financial Statement Schedules

(a) Exhibits.

The exhibit index attached hereto is incorporated herein by reference.

(b) Financial Statement Schedules.

(a) Exhibits. See the Exhibit Index immediately preceding the signature pages hereto, which is incorporated by reference as if fully set forth herein.

Item 17. Undertakings

The undersigned registrant hereby undertakes:

- (1) To file, during any period in which offers or sales are being made, a post-effective amendment to this registration statement:
 - (i) To include any prospectus required by section 10(a)(3) of the Securities Act of 1933;
 - (ii) To reflect in the prospectus any facts or events arising after the effective date of the registration statement (or the most recent post-effective amendment thereof) which, individually or in the aggregate, represent a fundamental change in the information set forth in the registration statement. Notwithstanding the foregoing, any increase or decrease in volume of securities offered (if the total dollar value of securities offered would not exceed that which was registered) and any deviation from the low or high end of the estimated maximum offering range may be reflected in the form of prospectus filed with the Commission pursuant to Rule 424(b) if, in the aggregate, the changes in volume and price represent no more than 20% change in the maximum aggregate offering price set forth in the "Calculation of Registration Fee" table in the effective registration statement.
 - (iii) To include any material information with respect to the plan of distribution not previously disclosed in the registration statement or any material change to such information in the registration statement;
- (2) That, for the purpose of determining any liability under the Securities Act of 1933, each such post-effective amendment shall be deemed to be a new registration statement relating to the securities offered therein, and the offering of such securities at that time shall be deemed to be the initial bona fide offering thereof.
- (3) To remove from registration by means of a post-effective amendment any of the securities being registered which remain unsold at the termination of the offering.
- (4) That, for the purpose of determining liability of the registrant under the Securities Act of 1933 to any purchaser in the initial distribution of the securities, that in a primary offering of securities of the undersigned registrant pursuant to this registration statement, regardless of the underwriting method used to sell the securities to the purchaser, if the securities are offered or sold to such purchaser by means of any of the following communications, the undersigned registrant will be a seller to the purchaser and will be considered to offer or sell such securities to such purchaser:

- a. Any preliminary prospectus or prospectus of the undersigned registrant relating to the offering required to be filed pursuant to Rule 424 (§ 230.424 of this chapter);
 - b. Any free writing prospectus relating to the offering prepared by or on behalf of the undersigned registrant or used or referred to by the undersigned registrant;
 - c. The portion of any other free writing prospectus relating to the offering containing material information about the undersigned registrant or its securities provided by or on behalf of the undersigned registrant; and
 - d. Any other communication that is an offer in the offering made by the undersigned registrant to the purchaser.
- (5) That, insofar as indemnification for liabilities arising under the Securities Act of 1933 may be permitted to directors, officers and controlling persons of the registrant pursuant to the foregoing provisions, or otherwise, the registrant has been advised that in the opinion of the Securities and Exchange Commission such indemnification is against public policy as expressed in the Act and is, therefore, unenforceable. In the event that a claim for indemnification against such liabilities (other than the payment by the registrant of expenses incurred or paid by a director, officer or controlling person of the registrant in the successful defense of any action, suit or proceeding) is asserted by such director, officer or controlling person in connection with the securities being registered, the registrant will, unless in the opinion of its counsel the matter has been settled by controlling precedent, submit to a court of appropriate jurisdiction the question whether such indemnification by it is against public policy as expressed in the Act and will be governed by the final adjudication of such issue.
- (6) That, for purposes of determining any liability under the Securities Act of 1933, the information omitted from the form of prospectus filed as part of this registration statement in reliance upon Rule 430A and contained in a form of prospectus filed by the registrant pursuant to Rule 424(b) (1) or (4) or 497(h) under the Securities Act shall be deemed to be part of this registration statement as of the time it was declared effective.
- (7) That, for the purpose of determining any liability under the Securities Act of 1933, each post-effective amendment that contains a form of prospectus shall be deemed to be a new registration statement relating to the securities offered therein, and the offering of such securities at that time shall be deemed to be the initial bona fide offering thereof.

SIGNATURES

Pursuant to the requirements of the Securities Act of 1933, as amended, the registrant has duly caused this Amendment No. 1 to the registration statement on Form S-1 to be signed on its behalf by the undersigned, thereunto duly authorized, in the City of Ft. Pierce, State of Florida, on the 8th day of February, 2022.

FORZA XI, INC.

By: /s/ Joseph C. Visconti
Name: Joseph C. Visconti
Title: Chairman of the Board and Chief Executive Officer
(Principal Executive Officer)

Pursuant to the requirements of the Securities Act of 1933, as amended, this Amendment No. 1 to the registration statement on Form S-1 has been signed by the following persons in the capacities and on the dates indicated.

Pursuant to the requirements of the Securities Act of 1933, as amended, this registration statement on Form S-1 has been signed by the following persons in the capacities and on the dates indicated.

<u>Signature</u>	<u>Title</u>	<u>Date</u>
<u>/s/ Joseph C. Visconti</u> Joseph C. Visconti	Chairman of the Board and Chief Executive Officer (Principal Executive Officer)	February 9, 2022
<u>*</u> Carrie Gunnerson	Chief Financial Officer (Principal Financial Officer and Principal Accounting Officer)	February 9, 2022
<u>*</u> Jim Leffew	President and Director	February 9, 2022
<u>*</u> Bard Rockenbach	Director	February 9, 2022
<u>*</u> Neil Ross	Director	February 9, 2022
<u>*</u> Kevin Schuyler	Director	February 9, 2022
<u>*</u> Steve Shallcross	Director	February 9, 2022
<u>*</u> Preston Yarborough	Director	February 9, 2022
<u>*By: /s/ Joseph C. Visconti</u> Joseph C. Visconti Attorney-In-Fact		

EXHIBIT INDEX

Exhibit No.	Description of Exhibit
1.1+	Form of Underwriting Agreement by and between Forza X1, Inc. and ThinkEquity LLC, as representative of the underwriters
3.1**	Certificate of Incorporation filed with the Secretary of State of Delaware on October 15, 2021
3.2**	Bylaws
3.3**	Certificate of Amendment to Certificate of Incorporation filed with the Secretary of State of Delaware on October 29, 2021
4.1+	Specimen Common Stock Certificate
4.2+	Form of Representative's Warrant Agreement
5.1+	Opinion of Blank Rome LLP
10.1+#	Forza X1, Inc. 2022 Stock Incentive Plan and form of Incentive Plan Option Agreement, Non-Qualified Stock Option Agreement, and Restricted Stock Unit Agreement
10.2**	Management Agreement, dated as of October 1, 2021, by and between Forza X1, Inc. and Twin Vee Powercats Co.
10.3**#	Employment Agreement, dated December 15, 2021, with Jim Leffew
10.4**†	Supply Agreement, dated December 20, 2021, by and between Forza X1, Inc. and American Battery Systems, Inc.
10.5*	Employment Agreement, dated June 9, 2021, between Twin Vee Powercats Co. and Joseph Visconti
10.6*	Employment Agreement, dated October 1, 2021, between Twin Vee Powercats Co. and Carrie Gunnerson
10.7*	Employment Agreement, dated June 9, 2021, between Twin Vee Powercats Co. and Preston Yarborough
21.1**	List of Subsidiaries of the Registrant
23.1*	Consent of Grassi & Co., CPAs, P.C., Independent Registered Public Accounting Firm
23.2+	Consent of Blank Rome LLP (contained in Exhibit 5.1)
24.1**	Power of Attorney (included on the signature page of this initial Registration Statement)
107*	Calculation of Filing Fee Table

* Filed herewith

** Previously Filed

+ To be filed by amendment

† Certain portions of the Supply Agreement have been omitted in accordance with Item 601(b)(10) of Regulation S-K. Forza X1 hereby undertakes to furnish to the Securities and Exchange Commission supplementally copies of any of the omitted portions of the Supply Agreement upon request.

Indicates a contract, compensatory plan or arrangement to which a director or executive officer is a party or in which one or more directors or executive officers are eligible to participate.

EMPLOYMENT AGREEMENT

THIS EMPLOYMENT AGREEMENT (the "Agreement"), effective as of the closing of the initial public offering (the "Effective Date") of Twin Vee PowerCats Co., a Delaware corporation, with its principal place of business located at 3101 S. US-1, Ft. Pierce, Florida 34982 (the "Company"), is entered into by and between Joseph Visconti, an individual residing in Florida ("Executive"), and the Company. Except as otherwise defined herein, capitalized terms and phrases shall have the meaning described thereto in Section 13 of this Agreement.

WHEREAS, the Company and Executive desire to set forth the terms and conditions under which Executive shall be employed, and upon which Executive shall be compensated by the Company.

WHEREAS, the Company desires to continue to employ Executive as its President and Chief Executive Officer for the period and upon the terms and conditions set forth in this Agreement.

WHEREAS, Executive desires to serve in such capacities for such period and upon such terms.

NOW THEREFORE, in consideration of the foregoing recitals, the mutual promises and agreements hereinafter set forth, and for other good and valuable consideration, the receipt and sufficiency of which are hereby acknowledged, the Company and Executive agree as follows:

1. **Term.** The Company agrees to employ Executive, and Executive accepts such employment with the Company, upon the terms and subject to the conditions set forth in this Agreement. Executive's employment shall commence as of the Effective Date and unless earlier terminated as provided herein, the initial term of this Agreement will be for a period of five (5) years, commencing on the date of this Agreement (the "Initial Term"); provided that thereafter this Agreement will be extended for additional one (1) year periods unless, no later than sixty (60) days prior to the expiration of the Initial Term or any such one (1) year extension period, as the case may be, either the Company or Executive provides notice to the other of its intent to terminate this Agreement upon the completion of the Initial Term or any such one (1) year extension period (the period of Executive's employment by the Company under this Agreement will be referred to as the "Term").

2. **Title; Duties; Board; Principal Place of Employment**

(a) **Title; Duties.** During the Term, Executive shall serve as the President and Chief Executive Officer of the Company, reporting directly to the Company's Board of Directors (the "Board"). Executive shall perform such specific duties as are commensurate with such positions and such other duties as may be assigned to Executive from time to time by the Board.

(b) **Board.** During the Term, Executive will be nominated to serve as a member of the Board for each election of the Board; provided, however, that Executive's continued service as a member of the Board will be subject to any required stockholder approval. Upon any cessation of Executive's employment, unless otherwise requested by the Board, Executive agrees to resign from all director and officer positions with the Company and its affiliates.

(c) **Principal Place of Employment.** Executive's services shall be performed principally at the Company's headquarters in Ft. Pierce, Florida. However, from time to time, Executive may also be required by his job responsibilities to travel on Company business, and Executive agrees to do so. Executive shall not be required to relocate from the Ft. Pierce, Florida area unless the Company relocates its corporate headquarters, in which event Executive may be required to relocate to such location.

3. **Outside Activities.** Executive shall serve the Company faithfully and to the best of his ability, shall use his business judgment, skill and best efforts to the advancement of the interests of the Company during the Term. Executive shall not engage, directly or indirectly, in any other business, investment or activity that (a) interferes with the performance of Executive's duties under this Agreement, (b) is contrary to the interests of the Company or any of its affiliates or (c) requires any portion of Executive's business time; provided, however, that, to the extent that the following does not impair Executive's ability to perform Executive's duties pursuant to this Agreement, Executive, with the Board's prior written approval (which approval may be withheld in the sole discretion of the Board), may serve on the board or committee of any non-profit, educational, religious, charitable or other similar organization, may have speaking engagements, and may serve as a member of the Board of Directors or equivalent of other organizations or companies (collectively, "Outside Activities"), provided, however, that if, after it provides prior written approval for an Outside Activity, the Board determines in good faith that such Outside Activity is inconsistent with applicable law or Company policy, or conflicts with Executive's obligations under this Agreement, Executive will cease any such Outside Activity upon written notice from the Board.

4. **Cash Compensation.**

(a) **Base Salary.** During the Term of this Agreement, Executive shall receive a base salary at a gross rate of Two Hundred and Fifty Thousand Dollars (\$250,000) per annum (the "Base Salary"), payable in substantially equal installments in accordance with the Company's normal payroll practices for payment of its employees, as in effect from time to time. Executive's Base Salary shall be subject to upward adjustment from time to time, as determined by the Board (or a committee thereof) in its sole discretion, but shall not be adjusted downward.

(b) **Bonuses - Other Compensation.** Executive shall be eligible to receive a target annual performance cash bonus of 100% of Executive's then-Base Salary ("Annual Target Bonus"). Executive's Annual Target Bonus is not guaranteed and will be based on the Company's performance and/or Executive's individual performance as determined by the Compensation Committee of the Board (the "Committee") in its discretion. The actual payout for this award will be calculated based solely on achievement against performance measures approved by the Committee. Each year, specific targets will be approved by the Committee in the year's first quarter and communicated to Executive following such approval. Performance against these goals will be assessed after year end, with payout made no later than March 15 of the year following the year in respect of which the bonus was earned, subject to Executive's continued employment through the payment date. In addition, during the Term of this Agreement, the Board, in its sole discretion, may award additional compensation to Executive other than as specifically provided by this Agreement.

(c) **Health Insurance.** During the Term of this Agreement, the Company shall pay for the cost of medical insurance for coverage for Executive and his family.

(d) **Car Allowance.** During the Term of this Agreement, Executive shall receive a \$2,500 a month car allowance.

5. **Equity Compensation.**

(a) **Initial Stock Option Grants.** As soon as practicable following the closing of the Company's initial public offering of stock, Executive will be granted a stock option to purchase Two Hundred Seventy Two Thousand (272,000) shares of Company common stock, pursuant to the Company's option agreement under the Company's 2021 Stock Incentive Plan or a successor thereto (the "Plan"). The option shall vest and become exercisable in 36 equal monthly installments commencing on the first day of the month following the issuance date, subject to Executive's continued employment through each such vesting date.

(b) Equity Grants. In its sole discretion, the Board may grant to Executive from time to time stock options to purchase shares of Company common stock or such other equity awards as it may determine.

6. Executive Benefits.

(a) Generally. During the Term of this Agreement, Executive shall be eligible to participate in all benefit and fringe benefit plans made available to other executive officers of the Company. Any such participation shall be subject to the terms and conditions of the applicable plan documents, applicable law, generally applicable Company policies, and the discretion of the Company, all as provided for in or contemplated by such plans. Subject to the terms of such plans and applicable law, the Company may alter, modify, add to or delete its employee benefit plans at any time, in its sole discretion, without recourse by Executive.

(b) Vacation. Executive shall be entitled to four (4) weeks per year paid vacation time as provided in the Company's vacation policies and procedures as in effect from time to time. Executive may take accrued vacation at such time or times as are mutually agreed upon by Executive and the Company. All matters relating to vacation time, including but not limited to accrual, carryover and forfeiture of vacation time, shall be governed by, and Executive agrees to be bound by, the Company's policies and procedures regarding vacation time as in effect from time to time.

7. Expenses. The Company will reimburse Executive for reasonable travel, entertainment and other expenses incurred by Executive in the furtherance of the performance of Executive's duties hereunder, in accordance with the Company's expense reimbursement policy as in effect from time to time. The Company and/or the Board may periodically audit or review such expenses to ensure they are for legitimate business expenses.

8. Deduction and Withholding. Notwithstanding any other provision of this Agreement, any payments or benefits hereunder shall be subject to the withholding of such amounts, if any, relating to tax and other payroll deductions, as the Company reasonably determines it should withhold pursuant to any applicable law or regulation.

9. Termination of Agreement.

(a) Termination Date. Executive's employment and this Agreement (except as otherwise provided hereunder) shall terminate upon the first to occur of any of the following, at the time set forth therefore (the "Termination Date"):

(i) Mutual Termination. At any time by the mutual written agreement of Company and Executive;

(ii) Death or Disability. Immediately upon the death of Executive or, subject to applicable law, a determination by Company that Executive has a Disability;

(iii) Voluntary Termination By Executive. 90 days following Executive's written notice to Company of termination of employment; provided, however, that Company may waive all or a portion of such notice period and accelerate the effective date of such termination (termination pursuant to this Subsection being referred to herein as "Voluntary" termination);

3

(iv) Termination For Cause By Company. Immediately following notice of termination for "Cause" given by Company (as defined below) and failure by Executive to Cure (as defined below), if applicable, with such notice specifying such Cause (termination pursuant to this Subsection being referred to herein as termination for "Cause");

(v) Termination Without Cause By Company. The Company may terminate without Cause Executive's employment under this Agreement at any time (termination pursuant to this Subsection being referred to herein as termination "Without Cause"); or

(vi) Termination For Good Reason by Executive. Subject to the notice and remedy provisions described in Section 14(d) below, at the election of Executive for Good Reason so long as the Separation From Service (as such phrase is defined in Code Section 409A; Treasury Regulations Section 1.409A-1(h)) on account of any such condition occurs not later than sixty (60) days following the expiration of the thirty-day (30-day) remedy period described in Section 14(d) below.

(b) No Limitation on Remedies. Termination pursuant to this Section 9 shall be in addition to and without prejudice to any other right or remedy to which Company may be entitled at law, in equity, or under this Agreement.

10. Basic Rights at Termination. In the event Executive's employment with the Company is terminated for any reason, Executive will be entitled to any (a) unpaid Base Salary accrued up to the effective date of termination; (b) benefits or compensation as provided under the terms of any employee benefit and compensation agreements or plans applicable to Executive; (c) unreimbursed business expenses required to be reimbursed to Executive in accordance with and subject to Company's policies applicable thereto; and (d) rights of indemnification to which Executive may be entitled as of the Termination Date under the Company's Certificate of Incorporation, Bylaws, this Agreement, or separate indemnification agreement, as applicable. In addition, Executive will be entitled to the amounts and benefits specified in Section 11 of this Agreement, to the extent applicable.

11. Termination Benefits.

(a) Termination Without Cause or Resignation for Good Reason other than In Connection with a Change of Control. If Executive's employment is terminated by the Company without Cause or if Executive resigns for Good Reason, and such termination is not In Connection with a Change of Control (as defined in Section 13(f) below), then, subject to Section 11(f), Executive will receive: (i) payment of an aggregate amount equal to Executive's monthly Base Salary as is in effect on the Termination Date multiplied by 12 (less applicable tax withholdings), such amounts to be paid out monthly in substantially equal installments over the six month period following such termination in accordance with the Company's normal payroll policies; (ii) payment of the annual bonus (pursuant to Section 4(b)) accrued for the year prior to such termination (to the extent not already paid); (iii) payment of Executive's annual bonus for the year of such termination, to the extent Executive would have received such bonus had Executive remained employed through the applicable payment date of such bonus, appropriately pro-rated based on the number of days that Executive was employed by the Company during the year of the termination, paid when the Company's other senior executive receive payment of their annual bonuses; (iv) full vesting with respect to Executive's then outstanding, unvested equity awards that were awarded under the Company's 2021 Stock Incentive Plan; (v) extension of the exercise period for all of Executive's then outstanding vested stock options (including those that vested pursuant to clause (iii) herein) to the first to occur of: the 6 month anniversary of the date of termination, the expiration date of the stock options, or such earlier time as provided under the applicable plan or grant agreement with respect to a Change of Control; and (vi) reimbursement for premiums paid for continued health benefits for Executive (and any eligible dependents) under the Company's health plans until the earlier of (x) twelve (12) months, payable when such premiums are due (provided Executive validly elects to continue coverage under the Consolidated Omnibus Budget Reconciliation Act ("COBRA") or similar state law or (y) the date upon which Executive and Executive's eligible dependents become covered under similar plans.

4

(b) Termination Without Cause or Resignation for Good Reason In Connection with a Change of Control. If Executive's employment is terminated by the Company without Cause or by Executive for Good Reason, and the termination is In Connection with a Change of Control, then, subject to Section 11(f), Executive will receive: (i) payment of an aggregate amount equal to Executive's monthly Base Salary as is in effect on the Termination Date multiplied by 18 (less applicable tax withholdings), such amounts to be paid out in substantially equal installments over the twelve month period following such termination in accordance with the Company's normal payroll policies; (ii) payment of the annual bonus (pursuant to Section 4(b)) accrued for the year prior to such termination (to the extent not already paid); (iii) Executive's then-current Annual Target Bonus; (iv) a pro-rata portion of Executive's Annual Target Bonus for the year of such termination paid in lump sum; (v) full vesting with respect to Executive's then outstanding, unvested equity awards that were granted under any of the Company's equity incentive plans; (vi) extension of the exercise period for all of Executive's outstanding stock options to the first to occur of: the 6 month anniversary of the date of termination, the expiration date of the stock options, or such earlier time as provided under the applicable plan or grant agreement with respect to a Change of Control; and (vii) reimbursement for premiums paid for continued health benefits for Executive (and any eligible dependents) under the Company's health plans until the earlier of (x) eighteen (18) months, payable when such premiums are due (provided Executive validly elects to continue coverage under COBRA or similar state law), or (y) the date upon which Executive and Executive's eligible dependents become covered under similar plans.

(c) Voluntary Termination Without Good Reason or Termination for Cause. If Executive's employment is terminated voluntarily by him without Good Reason or is terminated for Cause by the Company, then, except as otherwise provided in the first sentence of Section 10 above or Section 11(e), (i) all further vesting of Executive's outstanding equity awards will terminate immediately; and (ii) all payments of compensation by the Company to Executive hereunder will terminate immediately.

(d) Termination Due to Death or Disability. If Executive's employment is terminated due to death or Disability, and (x) such termination is not In Connection with a Change of Control, all outstanding, unvested equity awards that were awarded under the Company's 2021 Stock Incentive Plan will then vest, or (y) such termination is In Connection with a Change of Control, all outstanding, unvested equity awards granted under any of the Company's equity incentive plans will then vest. All outstanding vested stock options (including those that vested under (x) or (y) herein, will remain exercisable until the first to occur of: the 6 month anniversary of the date of termination, the expiration date of the stock options, or such earlier time as provided under the applicable plan or grant agreement with respect to a Change of Control. Except as otherwise provided in this Section 11(d), the first sentence of Section 10 above, or Section 11(e), all payments of compensation by the Company to Executive hereunder will terminate immediately upon Executive's termination.

(e) Separation Agreement and Release of Claims. The receipt of any severance or other benefits pursuant to Sections 11(a) or 11(b) will be subject to and conditioned on Executive first signing and not otherwise revoking a separation agreement and release of claims in substantially the form appended hereto as Exhibit A (the "Release Agreement"), which Release Agreement shall contain Executive's affirmation of his obligation not to compete with the Company as described in Section 15 herein. For this purpose, the Release Agreement must be signed by Executive and returned to the Company no later than thirty (30) days following the Termination Date in accordance with the terms of the Release Agreement. Notwithstanding any other provision of this Agreement to the contrary, no severance or other benefits will be paid or provided unless the Release Agreement becomes effective, and any severance amounts or benefits otherwise payable between the Termination Date and the forty-fifth (45th) day following the Termination Date will be paid on such forty-fifth (45th) day.

5

(f) No Duty to Mitigate. Executive will not be required to mitigate the amount of any payment contemplated by this Agreement, nor will any earnings that Executive may receive from any other source reduce any such payment.

12. Section 280G; Parachute Payments. If any payment or distribution by the Company to or for the benefit of Executive, whether paid or payable or distributed or distributable pursuant to the terms of this Agreement or otherwise pursuant to or by reason of any other agreement, policy, plan, program or arrangement or the lapse or termination of any restriction on or the vesting or exercisability of any payment or benefit (each a "Payment"), would be subject to the excise tax imposed by Code Section 4999 (or any successor provision thereto) or to any similar tax imposed by state or local law (such tax or taxes are hereafter collectively referred to as the "Excise Tax"), then the aggregate amount of Payments payable to Executive shall be reduced to the aggregate amount of Payments that may be made to Executive without incurring an excise tax (the "Safe-Harbor Amount") in accordance with the immediately following sentence; provided that such reduction shall only be imposed if the aggregate after-tax value of the Payments retained by Executive (after giving effect to such reduction) is equal to or greater than the aggregate after-tax value (after giving effect to the Excise Tax) of the Payments to Executive without any such reduction. Any such reduction shall be made in the following order: (i) first, any future cash payments (if any) shall be reduced (if necessary, to zero); (ii) second, any current cash payments shall be reduced (if necessary, to zero); (iii) third, all non-cash payments (other than equity or equity derivative related payments) shall be reduced (if necessary, to zero); and (iv) fourth, all equity or equity derivative payments shall be reduced.

13. Definitions.

(a) Cause. (A) Executive's conviction of or plea of nolo contendere to a felony; (B) Executive's commission of fraud, misappropriation or embezzlement against any person; (C) the theft or misappropriation by Executive of any property or money of the Company or an affiliate; (D) Executive's breach of the terms of this Agreement; or (E) the willful or gross neglect of Executive's duties, the willful or gross misconduct in performance of Executive's duties or the willful violation by Executive of any material Company policy. Notwithstanding the foregoing, Cause shall not exist with respect to subsection (D) or (E), until and unless Executive fails to cure such breach, neglect or misconduct (if such breach, neglect or misconduct is capable of cure) within 10 days after written notice from the Board.

(b) Code. shall mean the Internal Revenue Code of 1986, as amended from time to time.

(c) Change of Control. For purposes of this Agreement, "Change of Control" will mean the occurrence of any of the following events:

(i) The consummation by the Company of a merger or consolidation of the Company with any other corporation, other than a merger or consolidation which would result in the voting securities of the Company outstanding immediately prior thereto continuing to represent (either by remaining outstanding or by being converted into voting securities of the surviving entity) more than 50% of the total voting power represented by the voting securities of the Company or such surviving entity outstanding immediately after such merger or consolidation;

(ii) The approval by the stockholders of the Company, or if stockholder approval is not required, approval by the Board, of either (1) a plan of complete liquidation of the Company or (2) an agreement for the sale or disposition by the Company of all or substantially all of the Company's assets; or

6

(iii) Any "person" (as such term is used in Sections 13(d) and 14(d) of the Securities Exchange Act of 1934, as amended) becoming the "beneficial owner" (as defined in Rule 13d-3 under said Act), directly or indirectly, of securities of the Company representing 50% or more of the total voting power represented by the Company's then outstanding voting securities.

Notwithstanding the foregoing, a Change of Control will not be deemed to have occurred unless such event would also be a Change in Control under Code Section 409A or would otherwise be a permitted distribution event under Code Section 409A.

(d) Disability. For purposes of this Agreement, "Disability" will mean Executive's inability to substantially perform his duties under this Agreement as a result of

incapacity by reason of any medically determinable physical or mental impairment that can be expected to result in death or to last for a period of twelve (12) months.

(c) Good Reason. For purposes of this Agreement, "Good Reason" means the occurrence of any of the following conditions, without Executive's express written consent; provided, however, that Executive's employment is terminated no later than one hundred eighty (180) days following the initial existence of one or more of the following conditions; provided further, that Executive must provide the Company notice of Good Reason within ninety (90) days of the initial existence of one of the following conditions, upon which notice the Company shall then have thirty (30) days in which to remedy the condition, under which circumstances the Company shall not be required to pay any amounts specified in Section 11 of this Agreement:

- (i) A material diminution in Executive's authority, duties or responsibilities in effect immediately prior to such diminution;
- (ii) A material diminution in Executive's Base Salary that persists for longer than 12 months; or
- (iii) Any other action or inaction that constitutes a material breach by the Company of this Agreement.

(f) In Connection with a Change of Control. For purposes of this Agreement, a termination by Company of Executive's employment with the Company is "In Connection with a Change of Control" if Executive's employment is terminated by Company without Cause or by Executive for Good Reason within twelve (12) months following a Change of Control.

14. Return of Company Property and Records. Upon any termination of employment for any reason or no reason, or upon the Company's request at any time, Executive shall immediately return to the Company all property of the Company in Executive's possession (including computers, smart phones and other portable electronic devices) and all documents and other materials in any medium including but not limited to electronic, which relate in any way to the Company, including notebooks, correspondence, memos, drawings or diagrams, computer files and databases, graphics and formulas, whether prepared by Executive or by others and whether required by Executive's work or for his or her personal use, whether copies or originals, unless Executive first obtains the Company's written consent to keep such records.

15. Non-Competition. In consideration of the rights and benefits hereunder, including but not limited to the payments and benefits referenced in Section 11(g), Executive agrees that so long as he or she is an employee of the Company and for a period of twelve (12) months after the date of termination of Executive's employment for any reason (the "Restricted Period"), Executive shall not, without the prior written consent of the Company, own any interest in, control, participate in, work for, become employed by, or provide services to (whether as an employee, consultant, independent contractor or otherwise) any individual or entity that competes with the Company in the design, manufacture or marketing of recreational and commercial power catamaran boats. This Section 15 shall survive the termination of this Agreement.

7

16. Non-Solicitation. In consideration of the rights and benefits hereunder, Executive agrees that during the Restricted Period, he or she shall not, without the prior written consent of the Company: (i) solicit or encourage any employee of the Company or its affiliates to leave the employment of the Company or such affiliate; or (ii) solicit or encourage any client of the Company or any of its affiliates (including any investors in funds managed by the Company or its affiliates) to cease to do business with the Company or its affiliates. The only exceptions to the restrictions in this paragraph are: (i) clients (if any) with which Executive had a significant and provable business relationship prior to his/her employment with the Company, and (ii) where Executive has the express, prior written consent of the Board to be released in whole or part from this section of the Agreement. This Section 16 shall survive the termination of this Agreement.

17. Confidentiality. Executive agrees that during Executive's employment with the Company, will have access to confidential information and/or proprietary information about the Company and/or its clients, including, but not limited to, investment strategies, programs or ideas, trade secrets, methods, models, passwords, access to computer files, financial information and records, forecasts, computer software programs, agreements and/or contracts between the Company and its respective clients, client contracts, prospective contracts, creative policies and ideas, public relations and public affairs campaigns, media materials, budgets, practices, concepts, strategies, methods of operation, technical and scientific information, discoveries, developments, formulas, specifications, know-how, design inventions, marketing and business strategies and financial or business projects, and information about or received from clients and other companies with which the Company does business. The foregoing shall be collectively referred to as "Confidential Information." Any information that is not readily available to the public shall be considered to be Confidential Information, even if it is not specifically marked as such, unless the Company advises Executive otherwise in writing. Such Confidential Information is not readily available to the public and accordingly, Executive agrees that he or she will not at any time, whether during his or her employment with the Company or thereafter, disclose to anyone, (other than in furtherance of the business of the Company) any Confidential Information, or utilize such Confidential Information for his or her own benefit, or for the benefit of third parties. Executive also agrees to preserve and protect the confidentiality of any third party information similar to the Confidential Information to the same extent, and on the same basis, as the Company's Confidential Information. To the extent that any Confidential Information shall become the subject of any search warrant, court order, lawful subpoena, governmental investigation disclosure request or mandate, or the like (a "Disclosure Request"), Executive will notify the Company immediately, provide the Company adequate opportunity to oppose such Disclosure Request and reasonably assist the Company, at no cost to Executive, in opposing such Disclosure Request or seeking a protective order or such other limitation on disclosure as may be reasonably requested by the Company. If, after providing the notice and assistance required by the immediately preceding sentence, Executive is still required by lawful order to disclose any Confidential Information, Executive shall only disclose such information as is specifically required by such lawful order. The confidentiality protections available in this Agreement are in addition to, and not exclusive of, any and all other rights, including those provided under copyright, officer or director fiduciary duties and trade secret and confidential information laws. This confidentiality covenant has no temporal, geographical or territorial restriction. This Section 17 shall survive the termination of this Agreement.

8

Notwithstanding anything herein to the contrary, nothing in this Agreement shall (x) prohibit Executive from making reports of possible violations of federal law or regulation to any governmental agency or entity in accordance with the provisions of and rules promulgated under Section 21F of the Securities Exchange Act of 1934, as amended, or Section 806 of the Sarbanes-Oxley Act of 2002, or of any other whistleblower protection provisions of federal law or regulation, or (y) require notification or prior approval by the Company of any such report; provided that, Executive is not authorized to disclose communications with counsel that were made for the purpose of receiving legal advice or that contain legal advice or that are protected by the attorney work product or similar privilege.

DEFEND TRADE SECRETS ACT NOTICE AND RELATED PROVISIONS: The Defend Trade Secrets Act of 2016 provides as follows: (1) An individual shall not be held criminally or civilly liable under any federal or state trade secret law for the disclosure of a trade secret that is made in confidence to a federal, state or local government official or to an attorney and such disclosure is made (a) solely for the purpose of reporting or investigating a suspected violation of law or (b) in a complaint or other document filed in a lawsuit or other proceeding if such filing is made under seal. (2) An individual may disclose a trade secret to that individual's attorney for the purpose of filing a lawsuit for retaliation by an employer for reporting a suspected violation of law and use the trade secret information in the court proceeding provided the individual files any document containing the trade secret under seal and the individual does not disclose the trade secret except pursuant to court order. The Defend Trade Secrets Act also provides that a court enforcing that law may, if a trade secret is found to have been willfully and maliciously misappropriated, award (a) "exemplary damages" in an amount of up to two times the amount of damages awarded for actual loss caused by the misappropriation of a trade secret and damages for unjust enrichment caused by the misappropriation of the trade secret, or a reasonable royalty for the misappropriation, and (b) reasonable attorneys' fees against the misappropriating party.

18. Intellectual Property Assignment. For the purposes of this Agreement, the "business of the Company" is defined as the design, manufacture or marketing of recreational and commercial power catamaran boats. In the course of Executive's employment, Executive may develop, conceive, generate, or contribute to, alone and/or jointly

with others, tangible and intangible property including without limitation, inventions, improvements, business systems, works of authorship, algorithms, software, hardware, knowhow, designs, techniques, methods, documentation and other material, regardless of the form or media in or on which it is stored, some or all of which property may be protected by patents, copyrights, trade secrets, trade-marks, industrial designs or mask works, that relates to the business of the Company or to the Company's actual or demonstrably anticipated research and development, or relates to or incorporates any Confidential Information, and whether or not made on the Company's time or premises or using the Company's resources, equipment, supplies or facilities, (which tangible and intangible property is collectively referred to in this Agreement as "Proprietary Property").

All right, title and interest in and to Confidential Information and Proprietary Property (including, without limitation, the Proprietary Property described below), belongs to the Company, and Executive has no rights in any such Confidential Information and Proprietary Property. For greater certainty, all right, title and interest (including without limitation any intellectual property rights) in and to all Confidential Information and Proprietary Property that Executive may acquire or hold in the course of his or her employment is hereby assigned to the Company. Executive acknowledges that a Company customer or other third party (referred to in this Agreement as "Customer") may, under the terms of its agreement with the Company, own the applicable right, title and interest (including without limitation any intellectual property rights) in certain Proprietary Property (referred to in this Agreement as "Customer Proprietary Property") and Executive agrees to abide by any and all terms of said Customer agreements as they relate to Customer Proprietary Property and Customer confidential information.

Executive agrees that all of the work product that Executive helps to develop while employed with the Company is the exclusive property and Confidential Information of the Company. Any such work product will be considered to be a work made for hire. Executive agrees to make full disclosure to the Company of and to properly document any development of Proprietary Property that Executive is involved in, and to provide written documentation describing such development to the Company, promptly after its creation. At the request and expense of the Company, both during and after employment, Executive will do all acts necessary and sign all documentation requested by the Company in order to assign all right, title and interest in and to the Proprietary Property to the Company (or to the applicable Customer, in relation to Customer Proprietary Property) and to enable the Company (or the applicable Customer in relation to Customer Proprietary Property) to register (and to assist the Company to protect and defend its rights in and under any) patents, copyrights, trademarks, trade secrets, mask works, industrial designs and such other protections as the Company (or such Customer) deems advisable anywhere in the world. Executive hereby constitutes and appoints the Company and each and every director of the Company as Executive's true and lawful attorney with full power of substitution in Executive's name of and on Executive's behalf with no restriction or limitation in that regard, to execute and deliver all such documentation as may be necessary to permit any intellectual property application to be completed as provided in this Agreement; the foregoing power of attorney shall be irrevocable (to the fullest extent permitted by law) and is a power coupled with an interest and shall bind Executive and Executive's heirs, executors and legal personal representatives.

All notes, data, tapes, reference items, sketches, drawings, memoranda, records, documentation and other material regardless of the form or media in or on which it is stored, that is in or comes into Executive's possession or control, and that is in any way obtained, developed, conceived, generated or contributed to by Executive, alone and/or jointly with others, during or as a result of Executive's employment, is and remains Proprietary Property within the meaning of this Agreement.

The Company and Executive agree and understand that the Company claims no right and agrees to release to Executive all rights in any tangible or intangible property, provided that (i) it was developed by Executive entirely on Executive's own time, without using the Company's or any Customer's resources, equipment, supplies, facilities, or funds, (ii) it does not relate to the business of the Company or Customer or to the Company's or Customer's actual or demonstrably anticipated research and development, (iii) it does not relate to or incorporate any Confidential Information or result from any work performed by Executive for the Company or the Customer; and (iv) it was disclosed by Executive to the Company promptly after its creation.

Without limiting the generality of the foregoing, such property includes the excluded property listed on the attached Exhibit B. If disclosure would cause Executive to violate any prior confidentiality agreement, Executive understands that Executive is not to list details of such items in Exhibit B but instead to include a general/generic listing and to inform the Company that details have not been listed for that reason. If there is no attached Exhibit B, there is no such excluded property.

19 . Cooperation. Following the date of termination or expiration of this Agreement for any reason, upon the receipt of reasonable notice from the Company (including outside counsel to the Company) or their affiliates, Executive hereby agrees that he or she will respond and provide information with regard to matters in which he or she has knowledge as a result of his or her employment and association with the Company. Executive also agrees that he or she will provide reasonable assistance to the Company and its affiliates and their respective representatives in the defense of any claims that may be made against the Company or any of its affiliates, and will assist the Company and its affiliates in the prosecution of any claims that may be made by the Company or any of its affiliates to the extent that such claims may relate to the Term. Executive hereby agrees to promptly inform the Company (to the extent Executive is legally permitted to do so) if Executive is asked to assist in any investigation of the Company or any of its affiliates or their actions, regardless of whether a lawsuit or other proceeding has then been filed with respect to such investigation. This Section 19 shall survive the termination of this Agreement.

20 . Indemnification. Subject to applicable law, Executive will be provided indemnification to the maximum extent permitted by the Company's Articles of Incorporation, Bylaws, this Agreement, or separate indemnification agreement, as applicable, including, if applicable, any directors and officers insurance policies, with such indemnification to be on terms determined by the Board or any of its committees, but on terms no less favorable than provided to any other Company executive officer or director and subject to the terms of any separate written indemnification agreement.

21 . Section 409A. The following rules shall apply, to the extent necessary, with respect to distribution of the payments and benefits, if any, to be provided to Executive under this Agreement. Subject to the provisions in this Section, the severance payments pursuant to this Agreement shall begin only upon the date of Executive's "separation from service" (determined as set forth below) which occurs on or after the date of Executive's termination of employment.

(a) This Agreement is intended to comply with or be exempt from Code Section 409A and the parties hereto agree to interpret, apply and administer this Agreement in the least restrictive manner necessary to comply therewith or be exempt therefrom and without resulting in any increase in the amounts owed hereunder by the Company.

(b) It is intended that each installment of the severance payments and benefits provided under this Agreement shall be treated as a separate "payment" for purposes of Section 409A of the Code and the guidance issued thereunder ("Section 409A"). Neither Executive nor the Company shall have the right to accelerate or defer the delivery of any such payments or benefits except to the extent specifically permitted or required by Section 409A.

(c) If, as of the date of Executive's "separation from service" from the Company, Executive is a "specified employee" (within the meaning of Section 409A), then: each installment of the severance payments and benefits due under this Agreement that, in accordance with the dates and terms set forth herein, will in all circumstances, regardless of when the separation from service occurs, be paid within the short-term deferral period (as defined in Section 409A) shall be treated as a short-term deferral within the meaning of Treasury Regulation Section 1.409A-1(b)(4) to the maximum extent permissible under Section 409A; and each installment of the severance payments and benefits due under this Agreement that is not described in the preceding sentence and that would, absent this subsection, be paid within the six-month period following Executive's "separation from service" from the Company shall not be paid until the date that is six months and one day after such separation from service (or, if earlier, Executive's death), with any such installments that are required to be delayed being accumulated during the six-month period and paid in a lump sum on the date that is six months and one day following Executive's separation from service and any subsequent installments, if any, being paid in accordance with the dates and terms set forth herein; provided, however, that the preceding provisions of this sentence shall not apply to any installment of severance payments and benefits if and to the maximum extent that such

installment is deemed to be paid under a separation pay plan that does not provide for a deferral of compensation by reason of the application of Treasury Regulation 1.409A-1(b)(9)(iii) (relating to separation pay upon an involuntary separation from service). Any installments that qualify for the exception under Treasury Regulation Section 1.409A-1(b)(9)(iii) must be paid no later than the last day of the second taxable year following the taxable year in which the separation from service occurs.

(d) The determination of whether and when Executive's separation from service from the Company has occurred shall be made in a manner consistent with, and based on the presumptions set forth in, Treasury Regulation Section 1.409A-1(h). Solely for purposes of this Section, "Company" shall include all persons with whom the Company would be considered a single employer as determined under Treasury Regulation Section 1.409A-1(h)(3).

11

(e) All reimbursements and in-kind benefits provided under this Agreement shall be made or provided in accordance with the requirements of Section 409A to the extent that such reimbursements or in-kind benefits are subject to Section 409A, including, where applicable, the requirements that (i) any reimbursement is for expenses incurred during Executive's lifetime (or during a shorter period of time specified in this Agreement), (ii) the amount of expenses eligible for reimbursement during a calendar year may not affect the expenses eligible for reimbursement in any other calendar year, (iii) the reimbursement of an eligible expense will be made on or before the last day of the calendar year following the year in which the expense is incurred and (iv) the right to reimbursement is not subject to set off or liquidation or exchange for any other benefit.

(f) Notwithstanding anything herein to the contrary, the Company shall have no liability to Executive or to any other person if the payments and benefits provided in this Agreement that are intended to be exempt from or compliant with Section 409A are not so exempt or compliant.

2 2 . Notices. Any notice hereunder by either party to the other shall be given in writing by personal delivery or by registered mail, return receipt requested, addressed, if to the Company, to the attention of the Company's Chairman of the Board of Directors at the Company's principal offices or to such other address as the Company may designate in writing to Executive, and if to Executive, to his most recent home address on file with the Company. Notice shall be deemed given, if by personal delivery, on the date of such delivery or, if by registered mail, on the date shown on the applicable return receipt.

2 3 . Entire Agreement; Modification. This Agreement constitutes the entire understanding and agreement between the parties hereto with regard to the subject matter hereof, and supersedes all prior understandings and agreements, whether written or oral. This Agreement may not be amended, supplemented, revised or otherwise modified except by a writing signed by the parties hereto.

2 4 . Assignment. This Agreement may not be assigned, in whole or in part, by any party without the prior written consent of the other party, except that the Company may, without the consent of Executive, assign its rights and obligations under this Agreement to any corporation, firm or other business entity with or into which the Company may merge or consolidate, or to which the Company may sell or transfer all or substantially all of its assets. After any such assignment by the Company, the Company shall be discharged from all further liability hereunder and such assignee shall have all the rights and obligations of the Company under this Agreement.

25 . Captions, Sections and Headings. Captions, sections and headings herein have been inserted solely for convenience of reference and in no way limit the scope or substance of any provision of this Agreement.

2 6 . Severability. If any of the provisions of this Agreement is held to be excessively broad by any agency, tribunal or court of competent jurisdiction, it shall be reformed and construed by limiting and reducing it so as to be enforceable to the maximum extent permitted by law. If any portion or provision of this Agreement shall to any extent be declared illegal or unenforceable by any agency, tribunal or court of competent jurisdiction, even after the reformation and construction as described in the preceding sentence, then the remainder of this Agreement, or the application of such portion or provision in circumstances other than those as to which it is so declared illegal or unenforceable, shall not be affected thereby, and each portion and provision of this Agreement shall be valid and enforceable to the fullest extent permitted by law.

2 7 . Injunctive Relief. Executive acknowledges and agrees that the Company's remedies at law for a breach or threatened breach of this Agreement would be inadequate and, in recognition of this fact, Executive agrees that, in the event of such a breach or threatened breach, in addition to any remedies at law, the Company, without posting any bond, shall be entitled to obtain equitable relief in the form of specific performance, temporary restraining orders, temporary or permanent injunctions or any other equitable remedy which may then be available.

12

28 . Governing Law. This Agreement shall be governed by and construed in accordance with the laws of the State of Florida applicable to contracts executed and performed in such state without giving effect to conflicts of laws principles.

2 9 . Opportunity to Obtain Counsel; Acknowledgments. In connection with the preparation of this Agreement, Executive acknowledges and agrees that: (a) Executive has been advised that his interests may be opposed to the interests of Company and, accordingly, Company counsel's representation in the negotiation of this Agreement may not be in the best interests of Executive; and (b) Executive has been advised to and has so retained separate legal counsel. Executive warrants and agrees that he has read and fully understands the terms and conditions of this Agreement. By signing this Agreement, Executive is affirming that he has freely and of Executive's own volition acknowledged and agreed to all terms and conditions contained in this Agreement. Executive acknowledges that he had at least ten (10) business days to consider the terms of this Agreement prior to it becoming effective in accordance with its terms.

3 0 . Construction and Interpretation. Should any provision of this Agreement require judicial interpretation, the parties hereto agree that the court interpreting or construing the same shall not apply a presumption that the terms hereof shall be more strictly construed against one party by reason of the rule of construction that a document is to be more strictly construed against the party that itself, or through its agent, prepared the same, and it is expressly agreed and acknowledged that Company and Executive and each of his and its representatives, legal and otherwise, have participated in the preparation hereof.

31 . No Third Party Beneficiary. The terms and provisions of this Agreement are intended solely for the benefit of each party hereto and Company's successors or assigns, and it is not the intention of the parties to confer third-party beneficiary rights upon any other person.

32 . Waiver. No waiver of any provision hereof shall be effective unless made in writing and signed by the waiving party. The failure of either party to require the performance of any term or obligation of this Agreement, or the waiver by either party of any breach of this Agreement, shall not prevent any subsequent enforcement of such term or obligation or be deemed a waiver of any subsequent breach.

3 3 . Counterparts. This Agreement may be executed in two or more counterparts, each of which shall be deemed an original, but all of which together shall constitute one and the same instrument, and in pleading or proving any provision of this Agreement it shall not be necessary to produce more than one such counterpart. No counterpart shall be effective until each party has executed at least one counterpart. For the convenience of the parties, facsimile and pdf signatures shall be accepted as originals.

[Signature Page Follows]

13

IN WITNESS WHEREOF, the parties hereto have duly executed this Agreement as a binding contract as of the date first above written.

TWIN VEE POWERCATS, CO.

EXECUTIVE

By: /s/ Donna Barnett
Name: Donna Barnett
Title: Chief Financial Officer

By: /s/ Joseph Visconti
Name: Joseph Visconti

14

EXHIBIT A

FORM OF GENERAL RELEASE OF ALL CLAIMS

This General Release of All Claims is made as of _____, 202_ (“General Release”), by and between TWIN VEE POWERCATS CO. (the “Company”), and _____ (the “Executive”).

WHEREAS, the Company and Executive are parties to an Employment Agreement dated as of _____, 2021 (the “Employment Agreement”);

WHEREAS, the Company wishes to terminate Executive’s employment with the Company without Cause or the Executive wishes to resign with Good Reason;

WHEREAS, defined terms not defined in this General Release have the meanings given to them in the Employment Agreement;

WHEREAS, the execution of this General Release is a condition precedent to the payment of certain payments or benefits following the Executive’s termination, as set forth in Section 11 of the Employment Agreement;

WHEREAS, in consideration for Executive’s signing of this General Release, as well as Executive’s continued compliance with the Employment Agreement, including without limitation the non-competition and other restrictive covenants contained in Sections 15 through 17 of the Employment Agreement, the Company will provide such payments or benefits to which the Executive may be entitled pursuant to Section 11 of the Employment Agreement; and

WHEREAS, Executive and the Company intend that this General Release shall be in full satisfaction of the obligations described in Section 11(f) of the Employment Agreement owed by Executive to the Company.

NOW, THEREFORE, in consideration of the promises and the mutual covenants and agreements herein contained, the Company and Executive agree as follows:

1. Executive, for himself or herself, Executive’s spouse, heirs, administrators, children, representatives, executors, successors, assigns, and all other persons claiming through Executive, if any (collectively, “Releasers”), does hereby release, waive, and forever discharge the Company and each of its respective agents, subsidiaries, parents, affiliates, related organizations, members, partners, shareholders, employees, officers, directors, attorneys, successors, and assigns (collectively, the “Releasees”) from, and does fully waive any obligations of Releasees to Releasers for, any and all liability, actions, charges, causes of action, demands, damages, or claims for relief, remuneration, sums of money, accounts or expenses (including attorneys’ fees and costs) of any kind whatsoever, whether known or unknown or contingent or absolute, which heretofore has been or which hereafter may be suffered or sustained, directly or indirectly, by Releasers in consequence of, arising out of, or in any way relating to: (a) Executive’s employment with the Company or any of its subsidiaries or affiliates; (b) the termination of Executive’s employment with the Company and any of its subsidiaries or affiliates; (c) the Employment Agreement; or (d) any events occurring on or prior to the date of this General Release. The foregoing release and discharge, waiver and covenant not to sue includes, but is not limited to, all claims and any obligations or causes of action arising from such claims, under common law including wrongful or retaliatory discharge, breach of contract (including but not limited to any claims under the Employment Agreement and any claims under any equity incentive arrangements between Executive, on the one hand, and the Company or any of its subsidiaries or affiliates, on the other hand) and any action arising in tort including libel, slander, defamation or intentional

infliction of emotional distress, and claims under any federal, state or local statute including the Age Discrimination in Employment Act (“ADEA”), Title VII of the Civil Rights Act of 1964 (“Title VII”), the Civil Rights Act of 1866 and 1871 (42 U.S.C. § 1981), the National Labor Relations Act, the Fair Labor Standards Act, the Executive Retirement Income Security Act, the Americans with Disabilities Act of 1990 (“ADA”), the Rehabilitation Act of 1973, the discrimination or employment laws of any state or municipality, and/or any claims under any express or implied contract which Releasers may claim existed with Releasees. This also includes a release of any claims for wrongful discharge and all claims for alleged physical or personal injury, emotional distress relating to or arising out of Executive’s employment with the Company or any of its subsidiaries or affiliates or the termination of that employment; and any claims under the Worker Adjustment and Retraining Notification Act or any similar law, which requires, among other things, that advance notice be given of certain work force reductions. This release and waiver does not apply to: (i) any right to indemnification now existing under the Company’s governing documents; (ii) any rights to the receipt of Executive benefits under any Executive benefit plan which vested on or prior to the date of this General Release; (iii) the right to receive certain payments or benefits under Section 11 of the Employment Agreement; and (iv) the right to continuation health coverage pursuant to the Consolidated Omnibus Budget Reconciliation Act.

2. Excluded from this General Release and waiver are any claims which cannot be waived by law, including but not limited to the right to participate in an investigation conducted by certain government agencies. Executive does, however, waive Executive’s right to any monetary recovery should any agency (such as the Equal Employment Opportunity Commission) pursue any claims on Executive’s behalf. Executive represents and warrants that Executive has not filed any complaint, charge, or lawsuit against the Releasees with any government agency or any court.

3. Executive agrees never to seek personal recovery from Releasees in any forum for any claim covered by the above waiver and release language. If Executive violates this General Release by suing Releasees, Executive shall be liable to the Releasees for their reasonable attorneys’ fees and other litigation costs incurred in defending against such a suit and Executive shall reimburse the Releasees for their costs and expenses. Nothing in this General Release is intended to reflect any party’s belief that Executive’s waiver of claims under ADEA is invalid or unenforceable, it being the intent of the parties that such claims are waived.

4. To the extent, if any, that Executive has rights in any invention, improvement, discovery, process, program, product or system developed by Executive during his or her employment with the Company, Executive hereby irrevocably transfers, assigns and conveys such rights to the Company and agrees that the Company shall be and remain the sole and exclusive owner of all right, title and interest in and to any such invention, improvement, discovery, process, program, product or system, including, but not limited to, all patent, copyright, trade secret and other proprietary rights therein that may be secured in any place under laws now or hereinafter in effect.

5. Executive agrees that neither this General Release, nor the furnishing of the consideration for this General Release, shall be deemed or construed at any time to be an admission by the Company, any Releasees or Executive of any improper or unlawful conduct.

6. Executive acknowledges and recites that:
- (a) Executive has executed this General Release knowingly and voluntarily;
 - (b) Executive has read and understands this General Release in its entirety;
 - (c) Executive has been advised and directed orally and in writing (and this subparagraph (c))
-

(d) constitutes such written direction) to seek legal counsel and any other advice Executive wishes with respect to the terms of this General Release before executing it;

(e) By execution of this General Release, Executive expressly waives any and all claims relating to age discrimination and disability or handicap discrimination and releases any rights he may have under Title VII, ADEA, the ADA, and/or any State or local laws;

(f) Executive hereby acknowledges that the waiver of his or her rights and/or claims existing under Title VII, ADEA and ADA and/or any State or local laws is in consideration for payments or benefits to which the Executive is entitled under Section 11 of the Employment Agreement;

(g) Executive's execution of this General Release has not been forced by any Executive or agent of the Company, and Executive has had an opportunity to negotiate about the terms of this General Release; and

(h) Executive has been offered twenty-one (21) calendar days after receipt of this General Release to consider its terms before executing it.

7. This General Release shall be governed by the internal laws (and not the choice of laws) of the State of Florida, except for the application of pre-emptive Federal law.

8. Executive shall have seven (7) days from the date Executive executes this General Release to revoke Executive's waiver of any ADEA claims by providing written notice of the revocation to the Company. In the event that Executive revokes this General Release, the Company shall have no obligation to make any payments or benefits under Section 11 of the Employment Agreement that were expressly conditioned on the execution of this release.

9. Nothing in this General Release shall relieve Executive of his or her obligations under Sections 15 (Non-Competition), 16 (Non-Solicitation), or 17 (Confidentiality) of the Employment Agreement and Executive hereby agrees to comply with his or her obligations as set forth in Sections 15, 16, and 17 of the Employment Agreement.

10. If this General Release is found to be invalid or unenforceable in any way, the Executive shall execute and deliver to the Company a revised release which will effectuate Executive's intention to release the Releasees, as set forth herein, to the maximum extent permitted by law.

PLEASE READ THIS AGREEMENT CAREFULLY. IT CONTAINS A RELEASE OF ALL KNOWN AND UNKNOWN CLAIMS.

Date: _____

Executive

EXHIBIT B

EXCLUDED PROPERTY FROM INTELLECTUAL PROPERTY ASSIGNMENT

EMPLOYMENT AGREEMENT

THIS EMPLOYMENT AGREEMENT (the "Agreement"), effective as of October 1, 2021 (the "Effective Date") of Twin Vee PowerCats Co., a Delaware corporation, with its principal place of business located at 3101 S. US-1, Ft. Pierce, Florida 34982 (the "Company"), is entered into by and between Carrie Gunnerson, an individual residing in Florida ("Executive"), and the Company. Except as otherwise defined herein, capitalized terms and phrases shall have the meaning described thereto in Section 13 of this Agreement.

WHEREAS, the Company and Executive desire to set forth the terms and conditions under which Executive shall be employed, and upon which Executive shall be compensated by the Company.

WHEREAS, the Company desires to employ Executive as its Chief Financial Officer for the period and upon the terms and conditions set forth in this Agreement.

WHEREAS, Executive desires to serve in such capacities for such period and upon such terms.

NOW THEREFORE, in consideration of the foregoing recitals, the mutual promises and agreements hereinafter set forth, and for other good and valuable consideration, the receipt and sufficiency of which are hereby acknowledged, the Company and Executive agree as follows:

1. Term. The Company agrees to employ Executive, and Executive accepts such employment with the Company, upon the terms and subject to the conditions set forth in this Agreement. Executive's employment shall commence as of the Effective Date and unless earlier terminated as provided herein, the initial term of this Agreement will be for a period of five (5) years, commencing on the date of this Agreement (the "Initial Term"); provided that thereafter this Agreement will be extended for additional one (1) year periods unless, no later than sixty (60) days prior to the expiration of the Initial Term or any such one (1) year extension period, as the case may be, either the Company or Executive provides notice to the other of its intent to terminate this Agreement upon the completion of the Initial Term or any such one (1) year extension period (the period of Executive's employment by the Company under this Agreement will be referred to as the "Term").

2. Title; Duties; Board; Principal Place of Employment

(a) Title; Duties. During the Term, Executive shall serve as the Chief Financial Officer of the Company, reporting directly to the Company's Chief Executive Officer. Executive shall perform such specific duties as are commensurate with such positions and such other duties as may be assigned to Executive from time to time by the Chief Executive Officer.

(b) Principal Place of Employment. Executive's services shall be performed principally at the Company's headquarters in Ft. Pierce, Florida. However, from time to time, Executive may also be required by her job responsibilities to travel on Company business, and Executive agrees to do so. Executive shall not be required to relocate from the Ft. Pierce, Florida area unless the Company relocates its corporate headquarters, in which event Executive may be required to relocate to such location.

3. Outside Activities. Executive shall serve the Company faithfully and to the best of her ability, shall use her business judgment, skill and best efforts to the advancement of the interests of the Company during the Term. Executive shall not engage, directly or indirectly, in any other business, investment or activity that (a) interferes with the performance of Executive's duties under this Agreement, (b) is contrary to the interests of the Company or any of its affiliates, or (c) requires any portion of Executive's business time; provided, however, that, to the extent that the following does not impair Executive's ability to perform Executive's duties pursuant to this Agreement, Executive, with the Chief Executive Officer's prior written approval (which approval may be withheld in the sole discretion of the Chief Executive Officer), may serve on the board or committee of any non-profit, educational, religious, charitable or other similar organization, may have speaking engagements, and may serve as a member of the Board of Directors or equivalent of other organizations or companies (collectively, "Outside Activities"); provided, however, that if, after it provides prior written approval for an Outside Activity, the Chief Executive Officer determines in good faith that such Outside Activity is inconsistent with applicable law or Company policy, or conflicts with Executive's obligations under this Agreement, Executive will cease any such Outside Activity upon written notice from the Chief Executive Officer.

4. Cash Compensation

(a) Base Salary. During the Term of this Agreement, Executive shall receive a base salary at a gross rate of One Hundred Seventy Five Thousand Dollars (\$175,000) per annum (the "Base Salary"), payable in substantially equal installments in accordance with the Company's normal payroll practices for payment of its employees, as in effect from time to time. Executive's Base Salary shall be subject to upward adjustment from time to time, as determined by the Company's Board of Directors (the "Board"), or a committee thereof, in its sole discretion, but shall not be adjusted downward.

(b) Bonuses - Other Compensation. Executive shall be eligible to receive a target annual performance cash bonus of 30% of Executive's then-Base Salary ("Annual Target Bonus"). Executive's Annual Target Bonus is not guaranteed and will be based on the Company's performance and/or Executive's individual performance as determined by the Compensation Committee of the Board (the "Committee") in its discretion. The actual payout for this award will be calculated based solely on achievement against performance measures approved by the Committee. Each year, specific targets will be approved by the Committee in the year's first quarter and communicated to Executive following such approval. Performance against these goals will be assessed after year end, with payout made no later than March 15 of the year following the year in respect of which the bonus was earned, subject to Executive's continued employment through the payment date. In addition, during the Term of this Agreement, the Board, in its sole discretion, may award additional compensation to Executive other than as specifically provided by this Agreement.

(c) Health Insurance. During the Term of this Agreement, the Company shall pay for the cost of medical insurance for coverage for Executive and her spouse.

5. Equity Compensation

(a) Initial Stock Option Grants. Executive will be granted a stock option to purchase One Hundred and Thirty Six Thousand (136,000) shares of Company common stock, pursuant to the Company's option agreement under the Company's 2021 Stock Incentive Plan or a successor thereto (the "Plan"). The option shall vest and become exercisable in sixty (60) equal monthly installments commencing on the first day of the month following the issuance date, subject to Executive's continued employment through each such vesting date.

(b) Equity Grants. In its sole discretion, the Board may grant to Executive from time-to-time stock options to purchase shares of Company common stock or such other equity awards as it may determine.

6. Executive Benefits

(a) Generally. During the Term of this Agreement, Executive shall be eligible to participate in all benefit and fringe benefit plans made available to other executive officers of the Company. Any such participation shall be subject to the terms and conditions of the applicable plan documents, applicable law, generally applicable Company policies, and the discretion of the Company, all as provided for in or contemplated by such plans. Subject to the terms of such plans and applicable law, the Company may alter, modify, add to or delete its employee benefit plans at any time, in its sole discretion, without recourse by Executive.

(b) Vacation. Executive shall be entitled to four (4) weeks per year paid vacation time as provided in the Company's vacation policies and procedures as in effect from time to time. Executive may take accrued vacation at such time or times as are mutually agreed upon by Executive and the Company. All matters relating to vacation time, including but not limited to accrual, carryover and forfeiture of vacation time, shall be governed by, and Executive agrees to be bound by, the Company's policies and procedures regarding vacation time as in effect from time to time.

7. Expenses. The Company will reimburse Executive for reasonable travel, entertainment and other expenses incurred by Executive in the furtherance of the performance of Executive's duties hereunder, in accordance with the Company's expense reimbursement policy as in effect from time to time. The Company and/or the Board may periodically audit or review such expenses to ensure they are for legitimate business expenses.

8. Deduction and Withholding. Notwithstanding any other provision of this Agreement, any payments or benefits hereunder shall be subject to the withholding of such amounts, if any, relating to tax and other payroll deductions, as the Company reasonably determines it should withhold pursuant to any applicable law or regulation.

9. Termination of Agreement.

(a) Termination Date. Executive's employment and this Agreement (except as otherwise provided hereunder) shall terminate upon the first to occur of any of the following, at the time set forth therefore (the "Termination Date"):

(i) Mutual Termination. At any time by the mutual written agreement of Company and Executive;

(i i) Death or Disability. Immediately upon the death of Executive or, subject to applicable law, a determination by Company that Executive has a Disability;

(i i i) Voluntary Termination By Executive. Ninety (90) days following Executive's written notice to Company of termination of employment; provided, however, that Company may waive all or a portion of such notice period and accelerate the effective date of such termination (termination pursuant to this Subsection being referred to herein as "Voluntary" termination);

(i v) Termination For Cause By Company. Immediately following notice of termination for "Cause" given by Company (as defined below) and failure by Executive to Cure (as defined below), if applicable, with such notice specifying such Cause (termination pursuant to this Subsection being referred to herein as termination for "Cause");

3

(v) Termination Without Cause By Company. The Company may terminate without Cause Executive's employment under this Agreement at any time (termination pursuant to this Subsection being referred to herein as termination "Without Cause"); or

(v i) Termination For Good Reason by Executive. Subject to the notice and remedy provisions described in Section 14(d) below, at the election of Executive for Good Reason so long as the Separation From Service (as such phrase is defined in Code Section 409A; Treasury Regulations Section 1.409A-1(h)) on account of any such condition occurs not later than sixty (60) days following the expiration of the thirty-day (30-day) remedy period described in Section 14(d) below.

(b) No Limitation on Remedies. Termination pursuant to this Section 9 shall be in addition to and without prejudice to any other right or remedy to which Company may be entitled at law, in equity, or under this Agreement.

10. Basic Rights at Termination. In the event Executive's employment with the Company is terminated for any reason, Executive will be entitled to any (a) unpaid Base Salary accrued up to the effective date of termination; (b) benefits or compensation as provided under the terms of any employee benefit and compensation agreements or plans applicable to Executive; (c) unreimbursed business expenses required to be reimbursed to Executive in accordance with and subject to Company's policies applicable thereto; and (d) rights of indemnification to which Executive may be entitled as of the Termination Date under the Company's Certificate of Incorporation, Bylaws, this Agreement, or separate indemnification agreement, as applicable. In addition, Executive will be entitled to the amounts and benefits specified in Section 11 of this Agreement, to the extent applicable.

11. Termination Benefits.

(a) Termination Without Cause or Resignation for Good Reason. If Executive's employment is terminated by the Company without Cause or if Executive resigns for Good Reason during the first six (6) months following the Effective Date, Executive will receive a severance payment equal to Executive's monthly Base Salary as is in effect on the Termination Date multiplied by three (3) (less applicable tax withholdings), such amounts to be paid out monthly in substantially equal installments over the three (3) month period following such termination in accordance with the Company's normal payroll policies. If Executive's employment is terminated by the Company without Cause or if Executive resigns for Good Reason after the first six (6) months following the Effective Date, Executive will receive a severance payment equal to Executive's monthly Base Salary as is in effect on the Termination Date multiplied by six (6) (less applicable tax withholdings), such amounts to be paid out monthly in substantially equal installments over the six (6) month period following such termination in accordance with the Company's normal payroll policies.

(b) Voluntary Termination Without Good Reason or Termination for Cause. If Executive's employment is terminated voluntarily by her without Good Reason or is terminated for Cause by the Company, then, except as otherwise provided in the first sentence of Section 10 above or Section 11(d), (i) all further vesting of Executive's outstanding equity awards will terminate immediately; and (ii) all payments of compensation by the Company to Executive hereunder will terminate immediately.

(c) Termination Due to Death or Disability. If Executive's employment is terminated due to death or Disability, and (x) such termination is not In Connection with a Change of Control, all outstanding, unvested equity awards that were awarded under the Company's 2021 Stock Incentive Plan will then vest, or (y) such termination is In Connection with a Change of Control, all outstanding, unvested equity awards granted under any of the Company's equity incentive plans will then vest. All outstanding vested stock options (including those that vested under (x) or (y) herein, will remain exercisable until the first to occur of: the six (6) month anniversary of the date of termination, the expiration date of the stock options, or such earlier time as provided under the applicable plan or grant agreement with respect to a Change of Control. Except as otherwise provided in this Section 11(c), the first sentence of Section 10 above, or Section 11(d), all payments of compensation by the Company to Executive hereunder will terminate immediately upon Executive's termination.

4

(d) Separation Agreement and Release of Claims. The receipt of any severance or other benefits pursuant to Sections 11(a) or 11(b) will be subject to and

conditioned on Executive first signing and not otherwise revoking a separation agreement and release of claims in substantially the form appended hereto as Exhibit A (the "Release Agreement"), which Release Agreement shall contain Executive's affirmation of her obligation not to compete with the Company as described in Section 15 herein. For this purpose, the Release Agreement must be signed by Executive and returned to the Company no later than thirty (30) days following the Termination Date in accordance with the terms of the Release Agreement. Notwithstanding any other provision of this Agreement to the contrary, no severance or other benefits will be paid or provided unless the Release Agreement becomes effective, and any severance amounts or benefits otherwise payable between the Termination Date and the forty-fifth (45th) day following the Termination Date will be paid on such forty-fifth (45th) day.

(e) No Duty to Mitigate. Executive will not be required to mitigate the amount of any payment contemplated by this Agreement, nor will any earnings that Executive may receive from any other source reduce any such payment.

12. Section 280G; Parachute Payments. If any payment or distribution by the Company to or for the benefit of Executive, whether paid or payable or distributed or distributable pursuant to the terms of this Agreement or otherwise pursuant to or by reason of any other agreement, policy, plan, program or arrangement or the lapse or termination of any restriction on or the vesting or exercisability of any payment or benefit (each a "Payment"), would be subject to the excise tax imposed by Code Section 4999 (or any successor provision thereto) or to any similar tax imposed by state or local law (such tax or taxes are hereafter collectively referred to as the "Excise Tax"), then the aggregate amount of Payments payable to Executive shall be reduced to the aggregate amount of Payments that may be made to Executive without incurring an excise tax (the "Safe-Harbor Amount") in accordance with the immediately following sentence; provided that such reduction shall only be imposed if the aggregate after-tax value of the Payments retained by Executive (after giving effect to such reduction) is equal to or greater than the aggregate after-tax value (after giving effect to the Excise Tax) of the Payments to Executive without any such reduction. Any such reduction shall be made in the following order: (i) first, any future cash payments (if any) shall be reduced (if necessary, to zero); (ii) second, any current cash payments shall be reduced (if necessary, to zero); (iii) third, all non-cash payments (other than equity or equity derivative related payments) shall be reduced (if necessary, to zero); and (iv) fourth, all equity or equity derivative payments shall be reduced.

13. Definitions.

(a) Cause. (A) Executive's conviction of or plea of nolo contendere to a felony; (B) Executive's commission of fraud, misappropriation or embezzlement against any person; (C) the theft or misappropriation by Executive of any property or money of the Company or an affiliate; (D) Executive's breach of the terms of this Agreement; or (E) the willful or gross neglect of Executive's duties, the willful or gross misconduct in performance of Executive's duties or the willful violation by Executive of any material Company policy. Notwithstanding the foregoing, Cause shall not exist with respect to subsection (D) or (E), until and unless Executive fails to cure such breach, neglect or misconduct (if such breach, neglect or misconduct is capable of cure) within ten (10) days after written notice from the Board.

5

(b) Code. shall mean the Internal Revenue Code of 1986, as amended from time to time.

(c) Change of Control. For purposes of this Agreement, "Change of Control" will mean the occurrence of any of the following events:

(i) The consummation by the Company of a merger or consolidation of the Company with any other corporation, other than a merger or consolidation which would result in the voting securities of the Company outstanding immediately prior thereto continuing to represent (either by remaining outstanding or by being converted into voting securities of the surviving entity) more than 50% of the total voting power represented by the voting securities of the Company or such surviving entity outstanding immediately after such merger or consolidation;

(ii) The approval by the stockholders of the Company, or if stockholder approval is not required, approval by the Board, of either (1) a plan of complete liquidation of the Company or (2) an agreement for the sale or disposition by the Company of all or substantially all of the Company's assets; or

(iii) Any "person" (as such term is used in Sections 13(d) and 14(d) of the Securities Exchange Act of 1934, as amended) becoming the "beneficial owner" (as defined in Rule 13d-3 under said Act), directly or indirectly, of securities of the Company representing 50% or more of the total voting power represented by the Company's then outstanding voting securities.

Notwithstanding the foregoing, a Change of Control will not be deemed to have occurred unless such event would also be a Change in Control under Code Section 409A or would otherwise be a permitted distribution event under Code Section 409A.

(d) Disability. For purposes of this Agreement, "Disability" will mean Executive's inability to substantially perform her duties under this Agreement as a result of incapacity by reason of any medically determinable physical or mental impairment that can be expected to result in death or to last for a period of twelve (12) months.

(e) Good Reason. For purposes of this Agreement, "Good Reason" means the occurrence of any of the following conditions, without Executive's express written consent; provided, however, that Executive's employment is terminated no later than one hundred eighty (180) days following the initial existence of one or more of the following conditions; provided further, that Executive must provide the Company notice of Good Reason within ninety (90) days of the initial existence of one of the following conditions, upon which notice the Company shall then have thirty (30) days in which to remedy the condition, under which circumstances the Company shall not be required to pay any amounts specified in Section 11 of this Agreement:

(i) A material diminution in Executive's authority, duties or responsibilities in effect immediately prior to such diminution;

(ii) A material diminution in Executive's Base Salary that persists for longer than twelve (12) months; or

(iii) Any other action or inaction that constitutes a material breach by the Company of this Agreement.

(f) In Connection with a Change of Control. For purposes of this Agreement, a termination by Company of Executive's employment with the Company is "In Connection with a Change of Control" if Executive's employment is terminated by Company without Cause or by Executive for Good Reason within twelve (12) months following a Change of Control.

6

14. Return of Company Property and Records. Upon any termination of employment for any reason or no reason, or upon the Company's request at any time, Executive shall immediately return to the Company all property of the Company in Executive's possession (including computers, smart phones and other portable electronic devices) and all documents and other materials in any medium including but not limited to electronic, which relate in any way to the Company, including notebooks, correspondence, memos, drawings or diagrams, computer files and databases, graphics and formulas, whether prepared by Executive or by others and whether required by Executive's work or for her personal use, whether copies or originals, unless Executive first obtains the Company's written consent to keep such records.

15. Non-Competition. In consideration of the rights and benefits hereunder, including but not limited to the payments and benefits referenced in Section 11(g), Executive agrees that so long as she is an employee of the Company and for a period of twelve (12) months after the date of termination of Executive's employment for any

reason (the "Restricted Period"), Executive shall not, without the prior written consent of the Company, own any interest in, control, participate in, work for, become employed by, or provide services to (whether as an employee, consultant, independent contractor or otherwise) any individual or entity that competes with the Company in the design, manufacture or marketing of recreational and commercial power catamaran boats. This Section 15 shall survive the termination of this Agreement.

16. **Non-Solicitation.** In consideration of the rights and benefits hereunder, Executive agrees that during the Restricted Period, she shall not, without the prior written consent of the Company: (i) solicit or encourage any employee of the Company or its affiliates to leave the employment of the Company or such affiliate; or (ii) solicit or encourage any client of the Company or any of its affiliates (including any investors in funds managed by the Company or its affiliates) to cease to do business with the Company or its affiliates. The only exceptions to the restrictions in this paragraph are: (i) clients (if any) with which Executive had a significant and provable business relationship prior to her employment with the Company, and (ii) where Executive has the express, prior written consent of the Chief Executive Officer to be released in whole or part from this section of the Agreement. This Section 16 shall survive the termination of this Agreement.

17. **Confidentiality.** Executive agrees that during Executive's employment with the Company, will have access to confidential information and/or proprietary information about the Company and/or its clients, including, but not limited to, investment strategies, programs or ideas, trade secrets, methods, models, passwords, access to computer files, financial information and records, forecasts, computer software programs, agreements and/or contracts between the Company and its respective clients, client contracts, prospective contracts, creative policies and ideas, public relations and public affairs campaigns, media materials, budgets, practices, concepts, strategies, methods of operation, technical and scientific information, discoveries, developments, formulas, specifications, know-how, design inventions, marketing and business strategies and financial or business projects, and information about or received from clients and other companies with which the Company does business. The foregoing shall be collectively referred to as "Confidential Information." Any information that is not readily available to the public shall be considered to be Confidential Information, even if it is not specifically marked as such, unless the Company advises Executive otherwise in writing. Such Confidential Information is not readily available to the public and accordingly, Executive agrees that she will not at any time, whether during her employment with the Company or thereafter, disclose to anyone, (other than in furtherance of the business of the Company) any Confidential Information, or utilize such Confidential Information for her own benefit, or for the benefit of third parties. Executive also agrees to preserve and protect the confidentiality of any third party information similar to the Confidential Information to the same extent, and on the same basis, as the Company's Confidential Information. To the extent that any Confidential Information shall become the subject of any search warrant, court order, lawful subpoena, governmental investigation disclosure request or mandate, or the like (a "Disclosure Request"), Executive will notify the Company immediately, provide the Company adequate opportunity to oppose such Disclosure Request and reasonably assist the Company, at no cost to Executive, in opposing such Disclosure Request or seeking a protective order or such other limitation on disclosure as may be reasonably requested by the Company. If, after providing the notice and assistance required by the immediately preceding sentence, Executive is still required by lawful order to disclose any Confidential Information, Executive shall only disclose such information as is specifically required by such lawful order. The confidentiality protections available in this Agreement are in addition to, and not exclusive of, any and all other rights, including those provided under copyright, officer or director fiduciary duties and trade secret and confidential information laws. This confidentiality covenant has no temporal, geographical or territorial restriction. This Section 17 shall survive the termination of this Agreement.

7

Notwithstanding anything herein to the contrary, nothing in this Agreement shall (x) prohibit Executive from making reports of possible violations of federal law or regulation to any governmental agency or entity in accordance with the provisions of and rules promulgated under Section 21F of the Securities Exchange Act of 1934, as amended, or Section 806 of the Sarbanes-Oxley Act of 2002, or of any other whistleblower protection provisions of federal law or regulation, or (y) require notification or prior approval by the Company of any such report; provided that, Executive is not authorized to disclose communications with counsel that were made for the purpose of receiving legal advice or that contain legal advice or that are protected by the attorney work product or similar privilege.

DEFEND TRADE SECRETS ACT NOTICE AND RELATED PROVISIONS: The Defend Trade Secrets Act of 2016 provides as follows: (1) An individual shall not be held criminally or civilly liable under any federal or state trade secret law for the disclosure of a trade secret that is made in confidence to a federal, state or local government official or to an attorney and such disclosure is made (a) solely for the purpose of reporting or investigating a suspected violation of law or (b) in a complaint or other document filed in a lawsuit or other proceeding if such filing is made under seal. (2) An individual may disclose a trade secret to that individual's attorney for the purpose of filing a lawsuit for retaliation by an employer for reporting a suspected violation of law and use the trade secret information in the court proceeding provided the individual files any document containing the trade secret under seal and the individual does not disclose the trade secret except pursuant to court order. The Defend Trade Secrets Act also provides that a court enforcing that law may, if a trade secret is found to have been willfully and maliciously misappropriated, award (a) "exemplary damages" in an amount of up to two times the amount of damages awarded for actual loss caused by the misappropriation of a trade secret and damages for unjust enrichment caused by the misappropriation of the trade secret, or a reasonable royalty for the misappropriation, and (b) reasonable attorneys' fees against the misappropriating party.

18. **Intellectual Property Assignment.** For the purposes of this Agreement, the "business of the Company" is defined as the design, manufacture or marketing of recreational and commercial power catamaran boats. In the course of Executive's employment, Executive may develop, conceive, generate, or contribute to, alone and/or jointly with others, tangible and intangible property including without limitation, inventions, improvements, business systems, works of authorship, algorithms, software, hardware, knowhow, designs, techniques, methods, documentation and other material, regardless of the form or media in or on which it is stored, some or all of which property may be protected by patents, copyrights, trade secrets, trade-marks, industrial designs or mask works, that relates to the business of the Company or to the Company's actual or demonstrably anticipated research and development, or relates to or incorporates any Confidential Information, and whether or not made on the Company's time or premises or using the Company's resources, equipment, supplies or facilities, (which tangible and intangible property is collectively referred to in this Agreement as "Proprietary Property").

8

All right, title and interest in and to Confidential Information and Proprietary Property (including, without limitation, the Proprietary Property described below), belongs to the Company, and Executive has no rights in any such Confidential Information and Proprietary Property. For greater certainty, all right, title and interest (including without limitation any intellectual property rights) in and to all Confidential Information and Proprietary Property that Executive may acquire or hold in the course of her employment is hereby assigned to the Company. Executive acknowledges that a Company customer or other third party (referred to in this Agreement as "Customer") may, under the terms of its agreement with the Company, own the applicable right, title and interest (including without limitation any intellectual property rights) in certain Proprietary Property (referred to in this Agreement as "Customer Proprietary Property") and Executive agrees to abide by any and all terms of said Customer agreements as they relate to Customer Proprietary Property and Customer confidential information.

Executive agrees that all of the work product that Executive helps to develop while employed with the Company is the exclusive property and Confidential Information of the Company. Any such work product will be considered to be a work made for hire. Executive agrees to make full disclosure to the Company of and to properly document any development of Proprietary Property that Executive is involved in, and to provide written documentation describing such development to the Company, promptly after its creation. At the request and expense of the Company, both during and after employment, Executive will do all acts necessary and sign all documentation requested by the Company in order to assign all right, title and interest in and to the Proprietary Property to the Company (or to the applicable Customer, in relation to Customer Proprietary Property) and to enable the Company (or the applicable Customer in relation to Customer Proprietary Property) to register (and to assist the Company to protect and defend its rights in and under any) patents, copyrights, trademarks, trade secrets, mask works, industrial designs and such other protections as the Company (or such Customer) deems advisable anywhere in the world. Executive hereby constitutes and appoints the Company and each and every director of the Company as Executive's true and lawful attorney with full power of substitution in Executive's name of and on Executive's behalf with no restriction or limitation in that regard, to execute and deliver all such documentation as may be necessary to permit any intellectual property application to be completed as provided in this Agreement; the foregoing power of attorney shall be irrevocable (to the fullest extent permitted by law) and is a power coupled with an interest and shall bind Executive and Executive's heirs, executors and legal personal representatives.

All notes, data, tapes, reference items, sketches, drawings, memoranda, records, documentation and other material regardless of the form or media in or on which it is stored, that is in or comes into Executive's possession or control, and that is in any way obtained, developed, conceived, generated or contributed to by Executive, alone and/or jointly with others, during or as a result of Executive's employment, is and remains Proprietary Property within the meaning of this Agreement.

The Company and Executive agree and understand that the Company claims no right and agrees to release to Executive all rights in any tangible or intangible property, provided that (i) it was developed by Executive entirely on Executive's own time, without using the Company's or any Customer's resources, equipment, supplies, facilities, or funds, (ii) it does not relate to the business of the Company or Customer or to the Company's or Customer's actual or demonstrably anticipated research and development, (iii) it does not relate to or incorporate any Confidential Information or result from any work performed by Executive for the Company or the Customer; and (iv) it was disclosed by Executive to the Company promptly after its creation.

Without limiting the generality of the foregoing, such property includes the excluded property listed on the attached Exhibit B. If disclosure would cause Executive to violate any prior confidentiality agreement, Executive understands that Executive is not to list details of such items in Exhibit B but instead to include a general/generic listing and to inform the Company that details have not been listed for that reason. If there is no attached Exhibit B, there is no such excluded property.

9

19. Cooperation. Following the date of termination or expiration of this Agreement for any reason, upon the receipt of reasonable notice from the Company (including outside counsel to the Company) or their affiliates, Executive hereby agrees that she will respond and provide information with regard to matters in which she has knowledge as a result of her employment and association with the Company. Executive also agrees that she will provide reasonable assistance to the Company and its affiliates and their respective representatives in the defense of any claims that may be made against the Company or any of its affiliates, and will assist the Company and its affiliates in the prosecution of any claims that may be made by the Company or any of its affiliates to the extent that such claims may relate to the Term. Executive hereby agrees to promptly inform the Company (to the extent Executive is legally permitted to do so) if Executive is asked to assist in any investigation of the Company or any of its affiliates or their actions, regardless of whether a lawsuit or other proceeding has then been filed with respect to such investigation. This Section 19 shall survive the termination of this Agreement.

20. Indemnification. Subject to applicable law, Executive will be provided indemnification to the maximum extent permitted by the Company's Certificate of Incorporation, Bylaws, this Agreement, or separate indemnification agreement, as applicable, including, if applicable, any directors and officers insurance policies, with such indemnification to be on terms determined by the Board or any of its committees, but on terms no less favorable than provided to any other Company executive officer or director and subject to the terms of any separate written indemnification agreement.

21. Section 409A. The following rules shall apply, to the extent necessary, with respect to distribution of the payments and benefits, if any, to be provided to Executive under this Agreement. Subject to the provisions in this Section, the severance payments pursuant to this Agreement shall begin only upon the date of Executive's "separation from service" (determined as set forth below) which occurs on or after the date of Executive's termination of employment.

(a) This Agreement is intended to comply with or be exempt from Code Section 409A and the parties hereto agree to interpret, apply and administer this Agreement in the least restrictive manner necessary to comply therewith or be exempt therefrom and without resulting in any increase in the amounts owed hereunder by the Company.

(b) It is intended that each installment of the severance payments and benefits provided under this Agreement shall be treated as a separate "payment" for purposes of Section 409A of the Code and the guidance issued thereunder ("Section 409A"). Neither Executive nor the Company shall have the right to accelerate or defer the delivery of any such payments or benefits except to the extent specifically permitted or required by Section 409A.

(c) If, as of the date of Executive's "separation from service" from the Company, Executive is a "specified employee" (within the meaning of Section 409A), then: each installment of the severance payments and benefits due under this Agreement that, in accordance with the dates and terms set forth herein, will in all circumstances, regardless of when the separation from service occurs, be paid within the short-term deferral period (as defined in Section 409A) shall be treated as a short-term deferral within the meaning of Treasury Regulation Section 1.409A-1(b)(4) to the maximum extent permissible under Section 409A; and each installment of the severance payments and benefits due under this Agreement that is not described in the preceding sentence and that would, absent this subsection, be paid within the six (6) month period following Executive's "separation from service" from the Company shall not be paid until the date that is six (6) months and one day after such separation from service (or, if earlier, Executive's death), with any such installments that are required to be delayed being accumulated during the six (6) month period and paid in a lump sum on the date that is six (6) months and one day following Executive's separation from service and any subsequent installments, if any, being paid in accordance with the dates and terms set forth herein; provided, however, that the preceding provisions of this sentence shall not apply to any installment of severance payments and benefits if and to the maximum extent that such installment is deemed to be paid under a separation pay plan that does not provide for a deferral of compensation by reason of the application of Treasury Regulation 1.409A-1(b)(9)(iii) (relating to separation pay upon an involuntary separation from service). Any installments that qualify for the exception under Treasury Regulation Section 1.409A-1(b)(9)(iii) must be paid no later than the last day of the second taxable year following the taxable year in which the separation from service occurs.

10

(d) The determination of whether and when Executive's separation from service from the Company has occurred shall be made in a manner consistent with, and based on the presumptions set forth in, Treasury Regulation Section 1.409A-1(h). Solely for purposes of this Section, "Company" shall include all persons with whom the Company would be considered a single employer as determined under Treasury Regulation Section 1.409A-1(h)(3).

(e) All reimbursements and in-kind benefits provided under this Agreement shall be made or provided in accordance with the requirements of Section 409A to the extent that such reimbursements or in-kind benefits are subject to Section 409A, including, where applicable, the requirements that (i) any reimbursement is for expenses incurred during Executive's lifetime (or during a shorter period of time specified in this Agreement), (ii) the amount of expenses eligible for reimbursement during a calendar year may not affect the expenses eligible for reimbursement in any other calendar year, (iii) the reimbursement of an eligible expense will be made on or before the last day of the calendar year following the year in which the expense is incurred and (iv) the right to reimbursement is not subject to set off or liquidation or exchange for any other benefit.

(f) Notwithstanding anything herein to the contrary, the Company shall have no liability to Executive or to any other person if the payments and benefits provided in this Agreement that are intended to be exempt from or compliant with Section 409A are not so exempt or compliant.

22. Notices. Any notice hereunder by either party to the other shall be given in writing by personal delivery or by registered mail, return receipt requested, addressed, if to the Company, to the attention of the Company's Chief Executive Officer at the Company's principal offices or to such other address as the Company may designate in writing to Executive, and if to Executive, to her most recent home address on file with the Company. Notice shall be deemed given, if by personal delivery, on the date of such delivery or, if by registered mail, on the date shown on the applicable return receipt.

23. Entire Agreement; Modification. This Agreement constitutes the entire understanding and agreement between the parties hereto with regard to the subject matter hereof, and supersedes all prior understandings and agreements, whether written or oral. This Agreement may not be amended, supplemented, revised or otherwise modified except by a writing signed by the parties hereto.

24. Assignment. This Agreement may not be assigned, in whole or in part, by any party without the prior written consent of the other party, except that the Company may, without the consent of Executive, assign its rights and obligations under this Agreement to any corporation, firm or other business entity with or into which the Company may merge or consolidate, or to which the Company may sell or transfer all or substantially all of its assets. After any such assignment by the Company, the Company shall be discharged from all further liability hereunder and such assignee shall have all the rights and obligations of the Company under this Agreement.

25. Captions, Sections and Headings. Captions, sections and headings herein have been inserted solely for convenience of reference and in no way limit the scope or substance of any provision of this Agreement.

11

26. Severability. If any of the provisions of this Agreement is held to be excessively broad by any agency, tribunal or court of competent jurisdiction, it shall be reformed and construed by limiting and reducing it so as to be enforceable to the maximum extent permitted by law. If any portion or provision of this Agreement shall to any extent be declared illegal or unenforceable by any agency, tribunal or court of competent jurisdiction, even after the reformation and construction as described in the preceding sentence, then the remainder of this Agreement, or the application of such portion or provision in circumstances other than those as to which it is so declared illegal or unenforceable, shall not be affected thereby, and each portion and provision of this Agreement shall be valid and enforceable to the fullest extent permitted by law.

27. Injunctive Relief. Executive acknowledges and agrees that the Company's remedies at law for a breach or threatened breach of this Agreement would be inadequate and, in recognition of this fact, Executive agrees that, in the event of such a breach or threatened breach, in addition to any remedies at law, the Company, without posting any bond, shall be entitled to obtain equitable relief in the form of specific performance, temporary restraining orders, temporary or permanent injunctions or any other equitable remedy which may then be available.

28. Governing Law. This Agreement shall be governed by and construed in accordance with the laws of the State of Florida applicable to contracts executed and performed in such state without giving effect to conflicts of laws principles.

29. Opportunity to Obtain Counsel; Acknowledgments. In connection with the preparation of this Agreement, Executive acknowledges and agrees that: (a) Executive has been advised that her interests may be opposed to the interests of Company and, accordingly, Company counsel's representation in the negotiation of this Agreement may not be in the best interests of Executive; and (b) Executive has been advised to and has so retained separate legal counsel. Executive warrants and agrees that she has read and fully understands the terms and conditions of this Agreement. By signing this Agreement, Executive is affirming that she has freely and of Executive's own volition acknowledged and agreed to all terms and conditions contained in this Agreement. Executive acknowledges that she had at least ten (10) business days to consider the terms of this Agreement prior to it becoming effective in accordance with its terms.

30. Construction and Interpretation. Should any provision of this Agreement require judicial interpretation, the parties hereto agree that the court interpreting or construing the same shall not apply a presumption that the terms hereof shall be more strictly construed against one party by reason of the rule of construction that a document is to be more strictly construed against the party that itself, or through its agent, prepared the same, and it is expressly agreed and acknowledged that Company and Executive and each of her and its representatives, legal and otherwise, have participated in the preparation hereof.

31. No Third Party Beneficiary. The terms and provisions of this Agreement are intended solely for the benefit of each party hereto and Company's successors or assigns, and it is not the intention of the parties to confer third-party beneficiary rights upon any other person.

32. Waiver. No waiver of any provision hereof shall be effective unless made in writing and signed by the waiving party. The failure of either party to require the performance of any term or obligation of this Agreement, or the waiver by either party of any breach of this Agreement, shall not prevent any subsequent enforcement of such term or obligation or be deemed a waiver of any subsequent breach.

12

33. Counterparts. This Agreement may be executed in two or more counterparts, each of which shall be deemed an original, but all of which together shall constitute one and the same instrument, and in pleading or proving any provision of this Agreement it shall not be necessary to produce more than one such counterpart. No counterpart shall be effective until each party has executed at least one counterpart. For the convenience of the parties, facsimile and pdf signatures shall be accepted as originals.

[Signature Page Follows]

13

IN WITNESS WHEREOF, the parties hereto have duly executed this Agreement as a binding contract as of the date first above written.

TWIN VEE POWERCATS, CO.

EXECUTIVE

By: /s/ Joseph Visconti
Name: Joseph Visconti
Title: President & Chief Executive Officer

/s/ Carrie Gunnerson
Carrie Gunnerson

14

EXHIBIT A

FORM OF GENERAL RELEASE OF ALL CLAIMS

This General Release of All Claims is made as of _____, 202_ ("General Release"), by and between **TWIN VEE POWERCATS CO.** (the "Company"), and _____ (the "Executive").

WHEREAS, the Company and Executive are parties to an Employment Agreement dated as of _____, 2021 (the "Employment Agreement");

WHEREAS, the Company wishes to terminate Executive's employment with the Company without Cause or the Executive wishes to resign with Good Reason;

WHEREAS, defined terms not defined in this General Release have the meanings given to them in the Employment Agreement;

WHEREAS, the execution of this General Release is a condition precedent to the payment of certain payments or benefits following the Executive's termination, as set forth in Section 11 of the Employment Agreement;

WHEREAS, in consideration for Executive's signing of this General Release, as well as Executive's continued compliance with the Employment Agreement, including without limitation the non-competition and other restrictive covenants contained in Sections 15 through 17 of the Employment Agreement, the Company will provide such payments or benefits to which the Executive may be entitled pursuant to Section 11 of the Employment Agreement; and

WHEREAS, Executive and the Company intend that this General Release shall be in full satisfaction of the obligations described in Section 11(f) of the Employment Agreement owed by Executive to the Company.

NOW, THEREFORE, in consideration of the promises and the mutual covenants and agreements herein contained, the Company and Executive agree as follows:

1. Executive, for himself or herself, Executive's spouse, heirs, administrators, children, representatives, executors, successors, assigns, and all other persons claiming through Executive, if any (collectively, "Releasers"), does hereby release, waive, and forever discharge the Company and each of its respective agents, subsidiaries, parents, affiliates, related organizations, members, partners, shareholders, employees, officers, directors, attorneys, successors, and assigns (collectively, the "Releasees") from, and does fully waive any obligations of Releasees to Releasers for, any and all liability, actions, charges, causes of action, demands, damages, or claims for relief, remuneration, sums of money, accounts or expenses (including attorneys' fees and costs) of any kind whatsoever, whether known or unknown or contingent or absolute, which heretofore has been or which hereafter may be suffered or sustained, directly or indirectly, by Releasers in consequence of, arising out of, or in any way relating to: (a) Executive's employment with the Company or any of its subsidiaries or affiliates; (b) the termination of Executive's employment with the Company and any of its subsidiaries or affiliates; (c) the Employment Agreement; or (d) any events occurring on or prior to the date of this General Release. The foregoing release and discharge, waiver and covenant not to sue includes, but is not limited to, all claims and any obligations or causes of action arising from such claims, under common law including wrongful or retaliatory discharge, breach of contract (including but not limited to any claims under the Employment Agreement and any claims under any equity incentive arrangements between Executive, on the one hand, and the Company or any of its subsidiaries or affiliates, on the other hand) and any action arising in tort including libel, slander, defamation or intentional

infliction of emotional distress, and claims under any federal, state or local statute including the Age Discrimination in Employment Act ("ADEA"), Title VII of the Civil Rights Act of 1964 ("Title VII"), the Civil Rights Act of 1866 and 1871 (42 U.S.C. § 1981), the National Labor Relations Act, the Fair Labor Standards Act, the Executive Retirement Income Security Act, the Americans with Disabilities Act of 1990 ("ADA"), the Rehabilitation Act of 1973, the discrimination or employment laws of any state or municipality, and/or any claims under any express or implied contract which Releasers may claim existed with Releasees. This also includes a release of any claims for wrongful discharge and all claims for alleged physical or personal injury, emotional distress relating to or arising out of Executive's employment with the Company or any of its subsidiaries or affiliates or the termination of that employment; and any claims under the Worker Adjustment and Retraining Notification Act or any similar law, which requires, among other things, that advance notice be given of certain work force reductions. This release and waiver does not apply to: (i) any right to indemnification now existing under the Company's governing documents; (ii) any rights to the receipt of Executive benefits under any Executive benefit plan which vested on or prior to the date of this General Release; (iii) the right to receive certain payments or benefits under Section 11 of the Employment Agreement; and (iv) the right to continuation health coverage pursuant to the Consolidated Omnibus Budget Reconciliation Act.

2. Excluded from this General Release and waiver are any claims which cannot be waived by law, including but not limited to the right to participate in an investigation conducted by certain government agencies. Executive does, however, waive Executive's right to any monetary recovery should any agency (such as the Equal Employment Opportunity Commission) pursue any claims on Executive's behalf. Executive represents and warrants that Executive has not filed any complaint, charge, or lawsuit against the Releasees with any government agency or any court.

3. Executive agrees never to seek personal recovery from Releasees in any forum for any claim covered by the above waiver and release language. If Executive violates this General Release by suing Releasees, Executive shall be liable to the Releasees for their reasonable attorneys' fees and other litigation costs incurred in defending against such a suit and Executive shall reimburse the Releasees for their costs and expenses. Nothing in this General Release is intended to reflect any party's belief that Executive's waiver of claims under ADEA is invalid or unenforceable, it being the intent of the parties that such claims are waived.

4. To the extent, if any, that Executive has rights in any invention, improvement, discovery, process, program, product or system developed by Executive during her employment with the Company, Executive hereby irrevocably transfers, assigns and conveys such rights to the Company and agrees that the Company shall be and remain the sole and exclusive owner of all right, title and interest in and to any such invention, improvement, discovery, process, program, product or system, including, but not limited to, all patent, copyright, trade secret and other proprietary rights therein that may be secured in any place under laws now or hereinafter in effect.

5. Executive agrees that neither this General Release, nor the furnishing of the consideration for this General Release, shall be deemed or construed at any time to be an admission by the Company, any Releasees or Executive of any improper or unlawful conduct.

6. Executive acknowledges and recites that:

- (a) Executive has executed this General Release knowingly and voluntarily;
- (b) Executive has read and understands this General Release in its entirety;
- (c) Executive has been advised and directed orally and in writing (and this subparagraph (c))

(d) constitutes such written direction) to seek legal counsel and any other advice Executive wishes with respect to the terms of this General Release before executing it;

(e) By execution of this General Release, Executive expressly waives any and all claims relating to age discrimination and disability or handicap discrimination and releases any rights she may have under Title VII, ADEA, the ADA, and/or any State or local laws;

(f) Executive hereby acknowledges that the waiver of her rights and/or claims existing under Title VII, ADEA and ADA and/or any State or local laws is in consideration for payments or benefits to which the Executive is entitled under Section 11 of the Employment Agreement;

(g) Executive's execution of this General Release has not been forced by any Executive or agent of the Company, and Executive has had an opportunity to negotiate about the terms of this General Release; and

(h) Executive has been offered twenty-one (21) calendar days after receipt of this General Release to consider its terms before executing it.

7. This General Release shall be governed by the internal laws (and not the choice of laws) of the State of Florida, except for the application of pre-emptive Federal law.

8. Executive shall have seven (7) days from the date Executive executes this General Release to revoke Executive's waiver of any ADEA claims by providing written notice of the revocation to the Company. In the event that Executive revokes this General Release, the Company shall have no obligation to make any payments or benefits under Section 11 of the Employment Agreement that were expressly conditioned on the execution of this release.

9. Nothing in this General Release shall relieve Executive of her obligations under Sections 15 (Non-Competition), 16 (Non-Solicitation), or 17 (Confidentiality) of the Employment Agreement and Executive hereby agrees to comply with her obligations as set forth in Sections 15, 16, and 17 of the Employment Agreement.

10. If this General Release is found to be invalid or unenforceable in any way, the Executive shall execute and deliver to the Company a revised release which will effectuate Executive's intention to release the Releasees, as set forth herein, to the maximum extent permitted by law.

PLEASE READ THIS AGREEMENT CAREFULLY. IT CONTAINS A RELEASE OF ALL KNOWN AND UNKNOWN CLAIMS.

Date: _____ Executive _____

EXHIBIT B

EXCLUDED PROPERTY FROM INTELLECTUAL PROPERTY ASSIGNMENT

EMPLOYMENT AGREEMENT

THIS EMPLOYMENT AGREEMENT (the “Agreement”), effective as of the closing of the initial public offering (the “Effective Date”) of Twin Vee PowerCats Co., a Delaware corporation, with its principal place of business located at 3101 S. US-1, Ft. Pierce, Florida 34982 (the “Company”), is entered into by and between Preston Yarborough, an individual residing in Florida (“Executive”), and the Company. Except as otherwise defined herein, capitalized terms and phrases shall have the meaning described thereto in Section 13 of this Agreement.

WHEREAS, the Company and Executive desire to set forth the terms and conditions under which Executive shall be employed, and upon which Executive shall be compensated by the Company.

WHEREAS, the Company desires to continue to employ Executive as its Vice President for the period and upon the terms and conditions set forth in this Agreement.

WHEREAS, Executive desires to serve in such capacities for such period and upon such terms.

NOW THEREFORE, in consideration of the foregoing recitals, the mutual promises and agreements hereinafter set forth, and for other good and valuable consideration, the receipt and sufficiency of which are hereby acknowledged, the Company and Executive agree as follows:

1. Term. The Company agrees to employ Executive, and Executive accepts such employment with the Company, upon the terms and subject to the conditions set forth in this Agreement. Executive’s employment shall commence as of the Effective Date and unless earlier terminated as provided herein, the initial term of this Agreement will be for a period of five (5) years, commencing on the date of this Agreement (the “Initial Term”); provided that thereafter this Agreement will be extended for additional one (1) year periods unless, no later than sixty (60) days prior to the expiration of the Initial Term or any such one (1) year extension period, as the case may be, either the Company or Executive provides notice to the other of its intent to terminate this Agreement upon the completion of the Initial Term or any such one (1) year extension period (the period of Executive’s employment by the Company under this Agreement will be referred to as the “Term”).

2. Title; Duties; Board; Principal Place of Employment

(a) Title; Duties. During the Term, Executive shall serve as Vice President and Director of Product Development of the Company, reporting directly to the Company’s Chief Executive Officer. Executive shall perform such specific duties as are commensurate with such positions and such other duties as may be assigned to Executive from time to time by the Board.

(b) Board. During the Term, Executive shall continue to serve as a member of the Company’s Board of Directors (the “Board”) if nominated. Upon any cessation of Executive’s employment, unless otherwise requested by the Board, Executive agrees to resign from all director and officer positions with the Company and its affiliates.

(c) Principal Place of Employment. Executive’s services shall be performed principally at the Company’s headquarters in Ft. Pierce, Florida. However, from time to time, Executive may also be required by his job responsibilities to travel on Company business, and Executive agrees to do so. Executive shall not be required to relocate from the Ft. Pierce, Florida area unless the Company relocates its corporate headquarters, in which event Executive may be required to relocate to such location.

3. Outside Activities. Executive shall serve the Company faithfully and to the best of his ability, shall use his business judgment, skill and best efforts to the advancement of the interests of the Company during the Term. Executive shall not engage, directly or indirectly, in any other business, investment or activity that (a) interferes with the performance of Executive’s duties under this Agreement, (b) is contrary to the interests of the Company or any of its affiliates or (c) requires any portion of Executive’s business time; provided, however, that, to the extent that the following does not impair Executive’s ability to perform Executive’s duties pursuant to this Agreement, Executive, with the Board’s prior written approval (which approval may be withheld in the sole discretion of the Board), may serve on the board or committee of any non-profit, educational, religious, charitable or other similar organization, may have speaking engagements, and may serve as a member of the Board of Directors or equivalent of other organizations or companies (collectively, “Outside Activities”), provided, however, that if, after it provides prior written approval for an Outside Activity, the Board determines in good faith that such Outside Activity is inconsistent with applicable law or Company policy, or conflicts with Executive’s obligations under this Agreement, Executive will cease any such Outside Activity upon written notice from the Board.

4. Cash Compensation.

(a) Base Salary. During the Term of this Agreement, Executive shall receive a base salary at a gross rate of One Hundred Sixty Thousand Dollars (\$160,000) per annum (the “Base Salary”), payable in substantially equal installments in accordance with the Company’s normal payroll practices for payment of its employees, as in effect from time to time. Executive’s Base Salary shall be subject to upward adjustment from time to time, as determined by the Board (or a committee thereof) in its sole discretion, but shall not be adjusted downward.

(b) Bonuses - Other Compensation. Executive shall be eligible to receive a target annual performance cash bonus of 50% of Executive’s then-Base Salary (“Annual Target Bonus”). Executive’s Annual Target Bonus is not guaranteed and will be based on the Company’s performance and/or Executive’s individual performance as determined by the Compensation Committee of the Board (the “Committee”) in its discretion. The actual payout for this award will be calculated based solely on achievement against performance measures approved by the Committee. Each year, specific targets will be approved by the Committee in the year’s first quarter and communicated to Executive following such approval. Performance against these goals will be assessed after year end, with payout made no later than March 15 of the year following the year in respect of which the bonus was earned, subject to Executive’s continued employment through the payment date. In addition, during the Term of this Agreement, the Board, in its sole discretion, may award additional compensation to Executive other than as specifically provided by this Agreement.

(c) Health Insurance. During the Term of this Agreement, the Company shall pay for the cost of medical insurance for coverage for Executive and his family.

(d) Car Allowance. During the Term of this Agreement, Executive shall receive a \$1,000 a month car allowance.

5. Equity Compensation.

(a) Initial Stock Option Grants. As soon as practicable following the closing of the Company’s initial public offering of stock, Executive will be granted a stock option to purchase One Hundred Thirty Six (136,000) shares of Company common stock, pursuant to the Company’s option agreement under the Company’s 2021 Stock Incentive Plan or a successor thereto (the “Plan”). The option shall vest and become exercisable in 36 equal monthly installments commencing on the first day of the month following the issuance date, subject to Executive’s continued employment through each such vesting date.

(b) Equity Grants. In its sole discretion, the Board may grant to Executive from time to time stock options to purchase shares of Company common stock or such other equity awards as it may determine.

6. Executive Benefits.

(a) Generally. During the Term of this Agreement, Executive shall be eligible to participate in all benefit and fringe benefit plans made available to other executive officers of the Company. Any such participation shall be subject to the terms and conditions of the applicable plan documents, applicable law, generally applicable Company policies, and the discretion of the Company, all as provided for in or contemplated by such plans. Subject to the terms of such plans and applicable law, the Company may alter, modify, add to or delete its employee benefit plans at any time, in its sole discretion, without recourse by Executive.

(b) Vacation. Executive shall be entitled to four (4) weeks per year paid vacation time as provided in the Company's vacation policies and procedures as in effect from time to time. Executive may take accrued vacation at such time or times as are mutually agreed upon by Executive and the Company. All matters relating to vacation time, including but not limited to accrual, carryover and forfeiture of vacation time, shall be governed by, and Executive agrees to be bound by, the Company's policies and procedures regarding vacation time as in effect from time to time.

7. Expenses. The Company will reimburse Executive for reasonable travel, entertainment and other expenses incurred by Executive in the furtherance of the performance of Executive's duties hereunder, in accordance with the Company's expense reimbursement policy as in effect from time to time. The Company and/or the Board may periodically audit or review such expenses to ensure they are for legitimate business expenses.

8. Deduction and Withholding. Notwithstanding any other provision of this Agreement, any payments or benefits hereunder shall be subject to the withholding of such amounts, if any, relating to tax and other payroll deductions, as the Company reasonably determines it should withhold pursuant to any applicable law or regulation.

9. Termination of Agreement.

(a) Termination Date. Executive's employment and this Agreement (except as otherwise provided hereunder) shall terminate upon the first to occur of any of the following, at the time set forth therefore (the "Termination Date"):

(i) Mutual Termination. At any time by the mutual written agreement of Company and Executive;

(i i) Death or Disability. Immediately upon the death of Executive or, subject to applicable law, a determination by Company that Executive has a Disability;

(iii) Voluntary Termination By Executive. 90 days following Executive's written notice to Company of termination of employment; provided, however, that Company may waive all or a portion of such notice period and accelerate the effective date of such termination (termination pursuant to this Subsection being referred to herein as "Voluntary" termination);

3

(iv) Termination For Cause By Company. Immediately following notice of termination for "Cause" given by Company (as defined below) and failure by Executive to Cure (as defined below), if applicable, with such notice specifying such Cause (termination pursuant to this Subsection being referred to herein as termination for "Cause");

(v) Termination Without Cause By Company. The Company may terminate without Cause Executive's employment under this Agreement at any time (termination pursuant to this Subsection being referred to herein as termination "Without Cause"); or

(vi) Termination For Good Reason by Executive. Subject to the notice and remedy provisions described in Section 14(d) below, at the election of Executive for Good Reason so long as the Separation From Service (as such phrase is defined in Code Section 409A; Treasury Regulations Section 1.409A-1(h)) on account of any such condition occurs not later than sixty (60) days following the expiration of the thirty-day (30-day) remedy period described in Section 14(d) below.

(b) No Limitation on Remedies. Termination pursuant to this Section 9 shall be in addition to and without prejudice to any other right or remedy to which Company may be entitled at law, in equity, or under this Agreement.

10. Basic Rights at Termination. In the event Executive's employment with the Company is terminated for any reason, Executive will be entitled to any (a) unpaid Base Salary accrued up to the effective date of termination; (b) benefits or compensation as provided under the terms of any employee benefit and compensation agreements or plans applicable to Executive; (c) unreimbursed business expenses required to be reimbursed to Executive in accordance with and subject to Company's policies applicable thereto; and (d) rights of indemnification to which Executive may be entitled as of the Termination Date under the Company's Certificate of Incorporation, Bylaws, this Agreement, or separate indemnification agreement, as applicable. In addition, Executive will be entitled to the amounts and benefits specified in Section 11 of this Agreement, to the extent applicable.

11. Termination Benefits.

(a) Termination Without Cause or Resignation for Good Reason other than In Connection with a Change of Control. If Executive's employment is terminated by the Company without Cause or if Executive resigns for Good Reason, and such termination is not In Connection with a Change of Control (as defined in Section 13(f) below), then, subject to Section 11(f), Executive will receive: (i) payment of an aggregate amount equal to Executive's monthly Base Salary as is in effect on the Termination Date multiplied by 9 (less applicable tax withholdings), such amounts to be paid out monthly in substantially equal installments over the six month period following such termination in accordance with the Company's normal payroll policies; (ii) payment of the annual bonus (pursuant to Section 4(b)) accrued for the year prior to such termination (to the extent not already paid); (iii) full vesting with respect to Executive's then outstanding, unvested equity awards that were awarded under the Company's 2021 Stock Incentive Plan; (iv) extension of the exercise period for all of Executive's then outstanding vested stock options (including those that vested pursuant to clause (iii) herein) to the first to occur of: the 6 month anniversary of the date of termination, the expiration date of the stock options, or such earlier time as provided under the applicable plan or grant agreement with respect to a Change of Control; and (v) reimbursement for premiums paid for continued health benefits for Executive (and any eligible dependents) under the Company's health plans until the earlier of (x) nine (9) months, payable when such premiums are due (provided Executive validly elects to continue coverage under the Consolidated Omnibus Budget Reconciliation Act ("COBRA") or similar state law or (y) the date upon which Executive and Executive's eligible dependents become covered under similar plans.

4

(b) Termination Without Cause or Resignation for Good Reason In Connection with a Change of Control. If Executive's employment is terminated by the Company without Cause or by Executive for Good Reason, and the termination is In Connection with a Change of Control, then, subject to Section 11(f), Executive will receive: (i) payment of an aggregate amount equal to Executive's monthly Base Salary as is in effect on the Termination Date multiplied by 12 (less applicable tax withholdings), such

amounts to be paid out in substantially equal installments over the twelve month period following such termination in accordance with the Company's normal payroll policies; (ii) payment of the annual bonus (pursuant to Section 4(b)) accrued for the year prior to such termination (to the extent not already paid); (iii) Executive's then-current Annual Target Bonus; (iv) a pro-rata portion of Executive's Annual Target Bonus for the year of such termination paid in lump sum; (v) full vesting with respect to Executive's then outstanding, unvested equity awards that were granted under any of the Company's equity incentive plans; (vi) extension of the exercise period for all of Executive's outstanding stock options to the first to occur of: the 6 month anniversary of the date of termination, the expiration date of the stock options, or such earlier time as provided under the applicable plan or grant agreement with respect to a Change of Control; and (vii) reimbursement for premiums paid for continued health benefits for Executive (and any eligible dependents) under the Company's health plans until the earlier of (x) twelve (12) months, payable when such premiums are due (provided Executive validly elects to continue coverage under COBRA or similar state law), or (y) the date upon which Executive and Executive's eligible dependents become covered under similar plans.

(c) Voluntary Termination Without Good Reason or Termination for Cause. If Executive's employment is terminated voluntarily by him without Good Reason or is terminated for Cause by the Company, then, except as otherwise provided in the first sentence of Section 10 above or Section 11(e), (i) all further vesting of Executive's outstanding equity awards will terminate immediately; and (ii) all payments of compensation by the Company to Executive hereunder will terminate immediately.

(d) Termination Due to Death or Disability. If Executive's employment is terminated due to death or Disability, and (x) such termination is not In Connection with a Change of Control, all outstanding, unvested equity awards that were awarded under the Company's 2021 Stock Incentive Plan will then vest, or (y) such termination is In Connection with a Change of Control, all outstanding, unvested equity awards granted under any of the Company's equity incentive plans will then vest. All outstanding vested stock options (including those that vested under (x) or (y) herein, will remain exercisable until the first to occur of: the 6 month anniversary of the date of termination, the expiration date of the stock options, or such earlier time as provided under the applicable plan or grant agreement with respect to a Change of Control. Except as otherwise provided in this Section 11(d), the first sentence of Section 10 above, or Section 11(e), all payments of compensation by the Company to Executive hereunder will terminate immediately upon Executive's termination.

(e) Separation Agreement and Release of Claims. The receipt of any severance or other benefits pursuant to Sections 11(a) or 11(b) will be subject to and conditioned on Executive first signing and not otherwise revoking a separation agreement and release of claims in substantially the form appended hereto as Exhibit A (the "Release Agreement"), which Release Agreement shall contain Executive's affirmation of his obligation not to compete with the Company as described in Section 15 herein. For this purpose, the Release Agreement must be signed by Executive and returned to the Company no later than thirty (30) days following the Termination Date in accordance with the terms of the Release Agreement. Notwithstanding any other provision of this Agreement to the contrary, no severance or other benefits will be paid or provided unless the Release Agreement becomes effective, and any severance amounts or benefits otherwise payable between the Termination Date and the forty-fifth (45th) day following the Termination Date will be paid on such forty-fifth (45th) day.

5

(f) No Duty to Mitigate. Executive will not be required to mitigate the amount of any payment contemplated by this Agreement, nor will any earnings that Executive may receive from any other source reduce any such payment.

12. Section 280G: Parachute Payments. If any payment or distribution by the Company to or for the benefit of Executive, whether paid or payable or distributed or distributable pursuant to the terms of this Agreement or otherwise pursuant to or by reason of any other agreement, policy, plan, program or arrangement or the lapse or termination of any restriction on or the vesting or exercisability of any payment or benefit (each a "Payment"), would be subject to the excise tax imposed by Code Section 4999 (or any successor provision thereto) or to any similar tax imposed by state or local law (such tax or taxes are hereafter collectively referred to as the "Excise Tax"), then the aggregate amount of Payments payable to Executive shall be reduced to the aggregate amount of Payments that may be made to Executive without incurring an excise tax (the "Safe-Harbor Amount") in accordance with the immediately following sentence; provided that such reduction shall only be imposed if the aggregate after-tax value of the Payments retained by Executive (after giving effect to such reduction) is equal to or greater than the aggregate after-tax value (after giving effect to the Excise Tax) of the Payments to Executive without any such reduction. Any such reduction shall be made in the following order: (i) first, any future cash payments (if any) shall be reduced (if necessary, to zero); (ii) second, any current cash payments shall be reduced (if necessary, to zero); (iii) third, all non-cash payments (other than equity or equity derivative related payments) shall be reduced (if necessary, to zero); and (iv) fourth, all equity or equity derivative payments shall be reduced.

13. Definitions.

(a) Cause. (A) Executive's conviction of or plea of nolo contendere to a felony; (B) Executive's commission of fraud, misappropriation or embezzlement against any person; (C) the theft or misappropriation by Executive of any property or money of the Company or an affiliate; (D) Executive's breach of the terms of this Agreement; or (E) the willful or gross neglect of Executive's duties, the willful or gross misconduct in performance of Executive's duties or the willful violation by Executive of any material Company policy. Notwithstanding the foregoing, Cause shall not exist with respect to subsection (D) or (E), until and unless Executive fails to cure such breach, neglect or misconduct (if such breach, neglect or misconduct is capable of cure) within 10 days after written notice from the Board.

(b) Code. shall mean the Internal Revenue Code of 1986, as amended from time to time.

(c) Change of Control. For purposes of this Agreement, "Change of Control" will mean the occurrence of any of the following events:

(i) The consummation by the Company of a merger or consolidation of the Company with any other corporation, other than a merger or consolidation which would result in the voting securities of the Company outstanding immediately prior thereto continuing to represent (either by remaining outstanding or by being converted into voting securities of the surviving entity) more than 50% of the total voting power represented by the voting securities of the Company or such surviving entity outstanding immediately after such merger or consolidation;

(ii) The approval by the stockholders of the Company, or if stockholder approval is not required, approval by the Board, of either (1) a plan of complete liquidation of the Company or (2) an agreement for the sale or disposition by the Company of all or substantially all of the Company's assets; or

6

(iii) Any "person" (as such term is used in Sections 13(d) and 14(d) of the Securities Exchange Act of 1934, as amended) becoming the "beneficial owner" (as defined in Rule 13d-3 under said Act), directly or indirectly, of securities of the Company representing 50% or more of the total voting power represented by the Company's then outstanding voting securities.

Notwithstanding the foregoing, a Change of Control will not be deemed to have occurred unless such event would also be a Change in Control under Code Section 409A or would otherwise be a permitted distribution event under Code Section 409A.

(d) Disability. For purposes of this Agreement, "Disability" will mean Executive's inability to substantially perform his duties under this Agreement as a result of incapacity by reason of any medically determinable physical or mental impairment that can be expected to result in death or to last for a period of 180 days months.

(e) Good Reason. For purposes of this Agreement, "Good Reason" means the occurrence of any of the following conditions, without Executive's express written consent; provided, however, that Executive's employment is terminated no later than one hundred eighty (180) days following the initial existence of one or more of the

following conditions; provided further, that Executive must provide the Company notice of Good Reason within ninety (90) days of the initial existence of one of the following conditions, upon which notice the Company shall then have thirty (30) days in which to remedy the condition, under which circumstances the Company shall not be required to pay any amounts specified in Section 11 of this Agreement:

- (i) A material diminution in Executive's authority, duties or responsibilities in effect immediately prior to such diminution;
- (ii) A material diminution in Executive's Base Salary that persists for longer than 12 months; or
- (iii) Any other action or inaction that constitutes a material breach by the Company of this Agreement.

(f) In Connection with a Change of Control. For purposes of this Agreement, a termination by Company of Executive's employment with the Company is "In Connection with a Change of Control" if Executive's employment is terminated by Company without Cause or by Executive for Good Reason within twelve (12) months following a Change of Control.

14. Return of Company Property and Records. Upon any termination of employment for any reason or no reason, or upon the Company's request at any time, Executive shall immediately return to the Company all property of the Company in Executive's possession (including computers, smart phones and other portable electronic devices) and all documents and other materials in any medium including but not limited to electronic, which relate in any way to the Company, including notebooks, correspondence, memos, drawings or diagrams, computer files and databases, graphics and formulas, whether prepared by Executive or by others and whether required by Executive's work or for his or her personal use, whether copies or originals, unless Executive first obtains the Company's written consent to keep such records.

15. Non-Competition. In consideration of the rights and benefits hereunder, including but not limited to the payments and benefits referenced in Section 11(g), Executive agrees that so long as he or she is an employee of the Company and for a period of twelve (12) months after the date of termination of Executive's employment for any reason (the "Restricted Period"), Executive shall not, without the prior written consent of the Company, own any interest in, control, participate in, work for, become employed by, or provide services to (whether as an employee, consultant, independent contractor or otherwise) any individual or entity that competes with the Company in the design, manufacture or marketing of recreational and commercial power catamaran boats. This Section 15 shall survive the termination of this Agreement.

7

16. Non-Solicitation. In consideration of the rights and benefits hereunder, Executive agrees that during the Restricted Period, he or she shall not, without the prior written consent of the Company: (i) solicit or encourage any employee of the Company or its affiliates to leave the employment of the Company or such affiliate; or (ii) solicit or encourage any client of the Company or any of its affiliates (including any investors in funds managed by the Company or its affiliates) to cease to do business with the Company or its affiliates. The only exceptions to the restrictions in this paragraph are: (i) clients (if any) with which Executive had a significant and provable business relationship prior to his/her employment with the Company, and (ii) where Executive has the express, prior written consent of the Board to be released in whole or part from this section of the Agreement. This Section 16 shall survive the termination of this Agreement.

17. Confidentiality. Executive agrees that during Executive's employment with the Company, Executive will have access to confidential information and/or proprietary information about the Company and/or its clients, including, but not limited to, investment strategies, programs or ideas, trade secrets, methods, models, passwords, access to computer files, financial information and records, forecasts, computer software programs, agreements and/or contracts between the Company and its respective clients, client contracts, prospective contracts, creative policies and ideas, public relations and public affairs campaigns, media materials, budgets, practices, concepts, strategies, methods of operation, technical and scientific information, discoveries, developments, formulas, specifications, know-how, design inventions, marketing and business strategies and financial or business projects, and information about or received from clients and other companies with which the Company does business. The foregoing shall be collectively referred to as "Confidential Information." Any information that is not readily available to the public shall be considered to be Confidential Information, even if it is not specifically marked as such, unless the Company advises Executive otherwise in writing. Such Confidential Information is not readily available to the public and accordingly, Executive agrees that he or she will not at any time, whether during his or her employment with the Company or thereafter, disclose to anyone, (other than in furtherance of the business of the Company) any Confidential Information, or utilize such Confidential Information for his or her own benefit, or for the benefit of third parties. Executive also agrees to preserve and protect the confidentiality of any third party information similar to the Confidential Information to the same extent, and on the same basis, as the Company's Confidential Information. To the extent that any Confidential Information shall become the subject of any search warrant, court order, lawful subpoena, governmental investigation disclosure request or mandate, or the like (a "Disclosure Request"), Executive will notify the Company immediately, provide the Company adequate opportunity to oppose such Disclosure Request and reasonably assist the Company, at no cost to Executive, in opposing such Disclosure Request or seeking a protective order or such other limitation on disclosure as may be reasonably requested by the Company. If, after providing the notice and assistance required by the immediately preceding sentence, Executive is still required by lawful order to disclose any Confidential Information, Executive shall only disclose such information as is specifically required by such lawful order. The confidentiality protections available in this Agreement are in addition to, and not exclusive of, any and all other rights, including those provided under copyright, officer or director fiduciary duties and trade secret and confidential information laws. This confidentiality covenant has no temporal, geographical or territorial restriction. This Section 17 shall survive the termination of this Agreement.

8

Notwithstanding anything herein to the contrary, nothing in this Agreement shall (x) prohibit Executive from making reports of possible violations of federal law or regulation to any governmental agency or entity in accordance with the provisions of and rules promulgated under Section 21F of the Securities Exchange Act of 1934, as amended, or Section 806 of the Sarbanes-Oxley Act of 2002, or of any other whistleblower protection provisions of federal law or regulation, or (y) require notification or prior approval by the Company of any such report; provided that, Executive is not authorized to disclose communications with counsel that were made for the purpose of receiving legal advice or that contain legal advice or that are protected by the attorney work product or similar privilege.

DEFEND TRADE SECRETS ACT NOTICE AND RELATED PROVISIONS: The Defend Trade Secrets Act of 2016 provides as follows: (1) An individual shall not be held criminally or civilly liable under any federal or state trade secret law for the disclosure of a trade secret that is made in confidence to a federal, state or local government official or to an attorney and such disclosure is made (a) solely for the purpose of reporting or investigating a suspected violation of law or (b) in a complaint or other document filed in a lawsuit or other proceeding if such filing is made under seal. (2) An individual may disclose a trade secret to that individual's attorney for the purpose of filing a lawsuit for retaliation by an employer for reporting a suspected violation of law and use the trade secret information in the court proceeding provided the individual files any document containing the trade secret under seal and the individual does not disclose the trade secret except pursuant to court order. The Defend Trade Secrets Act also provides that a court enforcing that law may, if a trade secret is found to have been willfully and maliciously misappropriated, award (a) "exemplary damages" in an amount of up to two times the amount of damages awarded for actual loss caused by the misappropriation of a trade secret and damages for unjust enrichment caused by the misappropriation of the trade secret, or a reasonable royalty for the misappropriation, and (b) reasonable attorneys' fees against the misappropriating party.

18. Intellectual Property Assignment. For the purposes of this Agreement, the "business of the Company" is defined as the design, manufacture or marketing of recreational and commercial power catamaran boats. In the course of Executive's employment, Executive may develop, conceive, generate, or contribute to, alone and/or jointly with others, tangible and intangible property including without limitation, inventions, improvements, business systems, works of authorship, algorithms, software, hardware, knowhow, designs, techniques, methods, documentation and other material, regardless of the form or media in or on which it is stored, some or all of which property may be protected by patents, copyrights, trade secrets, trade-marks, industrial designs or mask works, that relates to the business of the Company or to the Company's actual or demonstrably anticipated research and development, or relates to or incorporates any Confidential Information, and whether or not made on the Company's time or premises or

using the Company's resources, equipment, supplies or facilities, (which tangible and intangible property is collectively referred to in this Agreement as "Proprietary Property").

All right, title and interest in and to Confidential Information and Proprietary Property (including, without limitation, the Proprietary Property described below), belongs to the Company, and Executive has no rights in any such Confidential Information and Proprietary Property. For greater certainty, all right, title and interest (including without limitation any intellectual property rights) in and to all Confidential Information and Proprietary Property that Executive may acquire or hold in the course of his or her employment is hereby assigned to the Company. Executive acknowledges that a Company customer or other third party (referred to in this Agreement as "Customer") may, under the terms of its agreement with the Company, own the applicable right, title and interest (including without limitation any intellectual property rights) in certain Proprietary Property (referred to in this Agreement as "Customer Proprietary Property") and Executive agrees to abide by any and all terms of said Customer agreements as they relate to Customer Proprietary Property and Customer confidential information.

9

Executive agrees that all of the work product that Executive helps to develop while employed with the Company is the exclusive property and Confidential Information of the Company. Any such work product will be considered to be a work made for hire. Executive agrees to make full disclosure to the Company of and to properly document any development of Proprietary Property that Executive is involved in, and to provide written documentation describing such development to the Company, promptly after its creation. At the request and expense of the Company, both during and after employment, Executive will do all acts necessary and sign all documentation requested by the Company in order to assign all right, title and interest in and to the Proprietary Property to the Company (or to the applicable Customer, in relation to Customer Proprietary Property) and to enable the Company (or the applicable Customer in relation to Customer Proprietary Property) to register (and to assist the Company to protect and defend its rights in and under any) patents, copyrights, trademarks, trade secrets, mask works, industrial designs and such other protections as the Company (or such Customer) deems advisable anywhere in the world. Executive hereby constitutes and appoints the Company and each and every director of the Company as Executive's true and lawful attorney with full power of substitution in Executive's name of and on Executive's behalf with no restriction or limitation in that regard, to execute and deliver all such documentation as may be necessary to permit any intellectual property application to be completed as provided in this Agreement; the foregoing power of attorney shall be irrevocable (to the fullest extent permitted by law) and is a power coupled with an interest and shall bind Executive and Executive's heirs, executors and legal personal representatives.

All notes, data, tapes, reference items, sketches, drawings, memoranda, records, documentation and other material regardless of the form or media in or on which it is stored, that is in or comes into Executive's possession or control, and that is in any way obtained, developed, conceived, generated or contributed to by Executive, alone and/or jointly with others, during or as a result of Executive's employment, is and remains Proprietary Property within the meaning of this Agreement.

The Company and Executive agree and understand that the Company claims no right and agrees to release to Executive all rights in any tangible or intangible property, provided that (i) it was developed by Executive entirely on Executive's own time, without using the Company's or any Customer's resources, equipment, supplies, facilities, or funds, (ii) it does not relate to the business of the Company or Customer or to the Company's or Customer's actual or demonstrably anticipated research and development, (iii) it does not relate to or incorporate any Confidential Information or result from any work performed by Executive for the Company or the Customer; and (iv) it was disclosed by Executive to the Company promptly after its creation.

Without limiting the generality of the foregoing, such property includes the excluded property listed on the attached Exhibit B. If disclosure would cause Executive to violate any prior confidentiality agreement, Executive understands that Executive is not to list details of such items in Exhibit B but instead to include a general/generic listing and to inform the Company that details have not been listed for that reason. If there is no attached Exhibit B, there is no such excluded property.

19 . Cooperation. Following the date of termination or expiration of this Agreement for any reason, upon the receipt of reasonable notice from the Company (including outside counsel to the Company) or their affiliates, Executive hereby agrees that he or she will respond and provide information with regard to matters in which he or she has knowledge as a result of his or her employment and association with the Company. Executive also agrees that he or she will provide reasonable assistance to the Company and its affiliates and their respective representatives in the defense of any claims that may be made against the Company or any of its affiliates, and will assist the Company and its affiliates in the prosecution of any claims that may be made by the Company or any of its affiliates to the extent that such claims may relate to the Term. Executive hereby agrees to promptly inform the Company (to the extent Executive is legally permitted to do so) if Executive is asked to assist in any investigation of the Company or any of its affiliates or their actions, regardless of whether a lawsuit or other proceeding has then been filed with respect to such investigation. This Section 19 shall survive the termination of this Agreement.

10

20 . Indemnification. Subject to applicable law, Executive will be provided indemnification to the maximum extent permitted by the Company's Articles of Incorporation, Bylaws, this Agreement, or separate indemnification agreement, as applicable, including, if applicable, any directors and officers insurance policies, with such indemnification to be on terms determined by the Board or any of its committees, but on terms no less favorable than provided to any other Company executive officer or director and subject to the terms of any separate written indemnification agreement.

21 . Section 409A. The following rules shall apply, to the extent necessary, with respect to distribution of the payments and benefits, if any, to be provided to Executive under this Agreement. Subject to the provisions in this Section, the severance payments pursuant to this Agreement shall begin only upon the date of Executive's "separation from service" (determined as set forth below) which occurs on or after the date of Executive's termination of employment.

(a) This Agreement is intended to comply with or be exempt from Code Section 409A and the parties hereto agree to interpret, apply and administer this Agreement in the least restrictive manner necessary to comply therewith or be exempt therefrom and without resulting in any increase in the amounts owed hereunder by the Company.

(b) It is intended that each installment of the severance payments and benefits provided under this Agreement shall be treated as a separate "payment" for purposes of Section 409A of the Code and the guidance issued thereunder ("Section 409A"). Neither Executive nor the Company shall have the right to accelerate or defer the delivery of any such payments or benefits except to the extent specifically permitted or required by Section 409A.

(c) If, as of the date of Executive's "separation from service" from the Company, Executive is a "specified employee" (within the meaning of Section 409A), then: each installment of the severance payments and benefits due under this Agreement that, in accordance with the dates and terms set forth herein, will in all circumstances, regardless of when the separation from service occurs, be paid within the short-term deferral period (as defined in Section 409A) shall be treated as a short-term deferral within the meaning of Treasury Regulation Section 1.409A-1(b)(4) to the maximum extent permissible under Section 409A; and each installment of the severance payments and benefits due under this Agreement that is not described in the preceding sentence and that would, absent this subsection, be paid within the six-month period following Executive's "separation from service" from the Company shall not be paid until the date that is six months and one day after such separation from service (or, if earlier, Executive's death), with any such installments that are required to be delayed being accumulated during the six-month period and paid in a lump sum on the date that is six months and one day following Executive's separation from service and any subsequent installments, if any, being paid in accordance with the dates and terms set forth herein; provided, however, that the preceding provisions of this sentence shall not apply to any installment of severance payments and benefits if and to the maximum extent that such installment is deemed to be paid under a separation pay plan that does not provide for a deferral of compensation by reason of the application of Treasury Regulation 1.409A-1(b)(9)(iii) (relating to separation pay upon an involuntary separation from service). Any installments that qualify for the exception under Treasury Regulation Section 1.409A-1(b)(9)(iii) must be paid no later than the last day of the second taxable year following the taxable year in which the separation from service occurs.

(d) The determination of whether and when Executive's separation from service from the Company has occurred shall be made in a manner consistent with, and based on the presumptions set forth in, Treasury Regulation Section 1.409A-1(h). Solely for purposes of this Section, "Company" shall include all persons with whom the Company would be considered a single employer as determined under Treasury Regulation Section 1.409A-1(h)(3).

11

(e) All reimbursements and in-kind benefits provided under this Agreement shall be made or provided in accordance with the requirements of Section 409A to the extent that such reimbursements or in-kind benefits are subject to Section 409A, including, where applicable, the requirements that (i) any reimbursement is for expenses incurred during Executive's lifetime (or during a shorter period of time specified in this Agreement), (ii) the amount of expenses eligible for reimbursement during a calendar year may not affect the expenses eligible for reimbursement in any other calendar year, (iii) the reimbursement of an eligible expense will be made on or before the last day of the calendar year following the year in which the expense is incurred and (iv) the right to reimbursement is not subject to set off or liquidation or exchange for any other benefit.

(f) Notwithstanding anything herein to the contrary, the Company shall have no liability to Executive or to any other person if the payments and benefits provided in this Agreement that are intended to be exempt from or compliant with Section 409A are not so exempt or compliant.

2 2 . Notices. Any notice hereunder by either party to the other shall be given in writing by personal delivery or by registered mail, return receipt requested, addressed, if to the Company, to the attention of the Company's Chairman of the Board of Directors at the Company's principal offices or to such other address as the Company may designate in writing to Executive, and if to Executive, to his most recent home address on file with the Company. Notice shall be deemed given, if by personal delivery, on the date of such delivery or, if by registered mail, on the date shown on the applicable return receipt.

2 3 . Entire Agreement; Modification. This Agreement constitutes the entire understanding and agreement between the parties hereto with regard to the subject matter hereof, and supersedes all prior understandings and agreements, whether written or oral. This Agreement may not be amended, supplemented, revised or otherwise modified except by a writing signed by the parties hereto.

2 4 . Assignment. This Agreement may not be assigned, in whole or in part, by any party without the prior written consent of the other party, except that the Company may, without the consent of Executive, assign its rights and obligations under this Agreement to any corporation, firm or other business entity with or into which the Company may merge or consolidate, or to which the Company may sell or transfer all or substantially all of its assets. After any such assignment by the Company, the Company shall be discharged from all further liability hereunder and such assignee shall have all the rights and obligations of the Company under this Agreement.

2 5 . Captions, Sections and Headings. Captions, sections and headings herein have been inserted solely for convenience of reference and in no way limit the scope or substance of any provision of this Agreement.

2 6 . Severability. If any of the provisions of this Agreement is held to be excessively broad by any agency, tribunal or court of competent jurisdiction, it shall be reformed and construed by limiting and reducing it so as to be enforceable to the maximum extent permitted by law. If any portion or provision of this Agreement shall to any extent be declared illegal or unenforceable by any agency, tribunal or court of competent jurisdiction, even after the reformation and construction as described in the preceding sentence, then the remainder of this Agreement, or the application of such portion or provision in circumstances other than those as to which it is so declared illegal or unenforceable, shall not be affected thereby, and each portion and provision of this Agreement shall be valid and enforceable to the fullest extent permitted by law.

2 7 . Injunctive Relief. Executive acknowledges and agrees that the Company's remedies at law for a breach or threatened breach of this Agreement would be inadequate and, in recognition of this fact, Executive agrees that, in the event of such a breach or threatened breach, in addition to any remedies at law, the Company, without posting any bond, shall be entitled to obtain equitable relief in the form of specific performance, temporary restraining orders, temporary or permanent injunctions or any other equitable remedy which may then be available.

12

2 8 . Governing Law. This Agreement shall be governed by and construed in accordance with the laws of the State of Florida applicable to contracts executed and performed in such state without giving effect to conflicts of laws principles.

2 9 . Opportunity to Obtain Counsel; Acknowledgments. In connection with the preparation of this Agreement, Executive acknowledges and agrees that: (a) Executive has been advised that his interests may be opposed to the interests of Company and, accordingly, Company counsel's representation in the negotiation of this Agreement may not be in the best interests of Executive; and (b) Executive has been advised to and has so retained separate legal counsel. Executive warrants and agrees that he has read and fully understands the terms and conditions of this Agreement. By signing this Agreement, Executive is affirming that he has freely and of Executive's own volition acknowledged and agreed to all terms and conditions contained in this Agreement. Executive acknowledges that he had at least ten (10) business days to consider the terms of this Agreement prior to it becoming effective in accordance with its terms.

3 0 . Construction and Interpretation. Should any provision of this Agreement require judicial interpretation, the parties hereto agree that the court interpreting or construing the same shall not apply a presumption that the terms hereof shall be more strictly construed against one party by reason of the rule of construction that a document is to be more strictly construed against the party that itself, or through its agent, prepared the same, and it is expressly agreed and acknowledged that Company and Executive and each of his and its representatives, legal and otherwise, have participated in the preparation hereof.

3 1 . No Third Party Beneficiary. The terms and provisions of this Agreement are intended solely for the benefit of each party hereto and Company's successors or assigns, and it is not the intention of the parties to confer third-party beneficiary rights upon any other person.

3 2 . Waiver. No waiver of any provision hereof shall be effective unless made in writing and signed by the waiving party. The failure of either party to require the performance of any term or obligation of this Agreement, or the waiver by either party of any breach of this Agreement, shall not prevent any subsequent enforcement of such term or obligation or be deemed a waiver of any subsequent breach.

3 3 . Counterparts. This Agreement may be executed in two or more counterparts, each of which shall be deemed an original, but all of which together shall constitute one and the same instrument, and in pleading or proving any provision of this Agreement it shall not be necessary to produce more than one such counterpart. No counterpart shall be effective until each party has executed at least one counterpart. For the convenience of the parties, facsimile and pdf signatures shall be accepted as originals.

[Signature Page Follows]

13

IN WITNESS WHEREOF, the parties hereto have duly executed this Agreement as a binding contract as of the date first above written.

TWIN VEE POWERCATS, CO.

EXECUTIVE

By: /s/ Joseph Visconti
Name: Joseph Visconti
Title: Chief Executive Officer

By: /s/ Preston Yarborough
Name: Preston Yarborough

14

EXHIBIT A

FORM OF GENERAL RELEASE OF ALL CLAIMS

This General Release of All Claims is made as of _____, 202_ (“General Release”), by and between TWIN VEE POWERCATS CO. (the “Company”), and _____ (the “Executive”).

WHEREAS, the Company and Executive are parties to an Employment Agreement dated as of _____, 2021 (the “Employment Agreement”);

WHEREAS, the Company wishes to terminate Executive’s employment with the Company without Cause or the Executive wishes to resign with Good Reason;

WHEREAS, defined terms not defined in this General Release have the meanings given to them in the Employment Agreement;

WHEREAS, the execution of this General Release is a condition precedent to the payment of certain payments or benefits following the Executive’s termination, as set forth in Section 11 of the Employment Agreement;

WHEREAS, in consideration for Executive’s signing of this General Release, as well as Executive’s continued compliance with the Employment Agreement, including without limitation the non-competition and other restrictive covenants contained in Sections 15 through 17 of the Employment Agreement, the Company will provide such payments or benefits to which the Executive may be entitled pursuant to Section 11 of the Employment Agreement; and

WHEREAS, Executive and the Company intend that this General Release shall be in full satisfaction of the obligations described in Section 11(f) of the Employment Agreement owed by Executive to the Company.

NOW, THEREFORE, in consideration of the promises and the mutual covenants and agreements herein contained, the Company and Executive agree as follows:

1. Executive, for himself or herself, Executive’s spouse, heirs, administrators, children, representatives, executors, successors, assigns, and all other persons claiming through Executive, if any (collectively, “Releasers”), does hereby release, waive, and forever discharge the Company and each of its respective agents, subsidiaries, parents, affiliates, related organizations, members, partners, shareholders, employees, officers, directors, attorneys, successors, and assigns (collectively, the “Releasees”) from, and does fully waive any obligations of Releasees to Releasers for, any and all liability, actions, charges, causes of action, demands, damages, or claims for relief, remuneration, sums of money, accounts or expenses (including attorneys’ fees and costs) of any kind whatsoever, whether known or unknown or contingent or absolute, which heretofore has been or which hereafter may be suffered or sustained, directly or indirectly, by Releasers in consequence of, arising out of, or in any way relating to: (a) Executive’s employment with the Company or any of its subsidiaries or affiliates; (b) the termination of Executive’s employment with the Company and any of its subsidiaries or affiliates; (c) the Employment Agreement; or (d) any events occurring on or prior to the date of this General Release. The foregoing release and discharge, waiver and covenant not to sue includes, but is not limited to, all claims and any obligations or causes of action arising from such claims, under common law including wrongful or retaliatory discharge, breach of contract (including but not limited to any claims under the Employment Agreement and any claims under any equity incentive arrangements between Executive, on the one hand, and the Company or any of its subsidiaries or affiliates, on the other hand) and any action arising in tort including libel, slander, defamation or intentional

infliction of emotional distress, and claims under any federal, state or local statute including the Age Discrimination in Employment Act (“ADEA”), Title VII of the Civil Rights Act of 1964 (“Title VII”), the Civil Rights Act of 1866 and 1871 (42 U.S.C. § 1981), the National Labor Relations Act, the Fair Labor Standards Act, the Executive Retirement Income Security Act, the Americans with Disabilities Act of 1990 (“ADA”), the Rehabilitation Act of 1973, the discrimination or employment laws of any state or municipality, and/or any claims under any express or implied contract which Releasers may claim existed with Releasees. This also includes a release of any claims for wrongful discharge and all claims for alleged physical or personal injury, emotional distress relating to or arising out of Executive’s employment with the Company or any of its subsidiaries or affiliates or the termination of that employment; and any claims under the Worker Adjustment and Retraining Notification Act or any similar law, which requires, among other things, that advance notice be given of certain work force reductions. This release and waiver does not apply to: (i) any right to indemnification now existing under the Company’s governing documents; (ii) any rights to the receipt of Executive benefits under any Executive benefit plan which vested on or prior to the date of this General Release; (iii) the right to receive certain payments or benefits under Section 11 of the Employment Agreement; and (iv) the right to continuation health coverage pursuant to the Consolidated Omnibus Budget Reconciliation Act.

2. Excluded from this General Release and waiver are any claims which cannot be waived by law, including but not limited to the right to participate in an investigation conducted by certain government agencies. Executive does, however, waive Executive’s right to any monetary recovery should any agency (such as the Equal Employment Opportunity Commission) pursue any claims on Executive’s behalf. Executive represents and warrants that Executive has not filed any complaint, charge, or lawsuit against the Releasees with any government agency or any court.

3. Executive agrees never to seek personal recovery from Releasees in any forum for any claim covered by the above waiver and release language. If Executive violates this General Release by suing Releasees, Executive shall be liable to the Releasees for their reasonable attorneys’ fees and other litigation costs incurred in defending against such a suit and Executive shall reimburse the Releasees for their costs and expenses. Nothing in this General Release is intended to reflect any party’s belief that Executive’s waiver of claims under ADEA is invalid or unenforceable, it being the intent of the parties that such claims are waived.

4. To the extent, if any, that Executive has rights in any invention, improvement, discovery, process, program, product or system developed by Executive during his or her employment with the Company, Executive hereby irrevocably transfers, assigns and conveys such rights to the Company and agrees that the Company shall be and remain the sole and exclusive owner of all right, title and interest in and to any such invention, improvement, discovery, process, program, product or system, including, but not limited to, all patent, copyright, trade secret and other proprietary rights therein that may be secured in any place under laws now or hereinafter in effect.

5. Executive agrees that neither this General Release, nor the furnishing of the consideration for this General Release, shall be deemed or construed at any time to be an admission by the Company, any Releasees or Executive of any improper or unlawful conduct.

6. Executive acknowledges and recites that:

- (a) Executive has executed this General Release knowingly and voluntarily;
 - (b) Executive has read and understands this General Release in its entirety;
 - (c) Executive has been advised and directed orally and in writing (and this subparagraph (c))
-

(d) constitutes such written direction) to seek legal counsel and any other advice Executive wishes with respect to the terms of this General Release before executing it;

(e) By execution of this General Release, Executive expressly waives any and all claims relating to age discrimination and disability or handicap discrimination and releases any rights he may have under Title VII, ADEA, the ADA, and/or any State or local laws;

(f) Executive hereby acknowledges that the waiver of his or her rights and/or claims existing under Title VII, ADEA and ADA and/or any State or local laws is in consideration for payments or benefits to which the Executive is entitled under Section 11 of the Employment Agreement;

(g) Executive's execution of this General Release has not been forced by any Executive or agent of the Company, and Executive has had an opportunity to negotiate about the terms of this General Release; and

(h) Executive has been offered twenty-one (21) calendar days after receipt of this General Release to consider its terms before executing it.

7. This General Release shall be governed by the internal laws (and not the choice of laws) of the State of Florida, except for the application of pre-emptive Federal law.

8. Executive shall have seven (7) days from the date Executive executes this General Release to revoke Executive's waiver of any ADEA claims by providing written notice of the revocation to the Company. In the event that Executive revokes this General Release, the Company shall have no obligation to make any payments or benefits under Section 11 of the Employment Agreement that were expressly conditioned on the execution of this release.

9. Nothing in this General Release shall relieve Executive of his or her obligations under Sections 15 (Non-Competition), 16 (Non-Solicitation), or 17 (Confidentiality) of the Employment Agreement and Executive hereby agrees to comply with his or her obligations as set forth in Sections 15, 16, and 17 of the Employment Agreement.

10. If this General Release is found to be invalid or unenforceable in any way, the Executive shall execute and deliver to the Company a revised release which will effectuate Executive's intention to release the Releasees, as set forth herein, to the maximum extent permitted by law.

PLEASE READ THIS AGREEMENT CAREFULLY. IT CONTAINS A RELEASE OF ALL KNOWN AND UNKNOWN CLAIMS.

Date: _____

Executive

EXHIBIT B

EXCLUDED PROPERTY FROM INTELLECTUAL PROPERTY ASSIGNMENT

Calculation of Filing Fee Tables

S-1

(Form Type)

ForzaX1, Inc.

(Exact Name of Registrant as Specified in its Charter)

Table 1: Newly Registered Securities

	Security Type	Security Class Title	Fee Calculation or Carry Forward Rule	Amount Registered	Proposed Maximum Offering Price Per Unit	Maximum Aggregate Offering Price	Fee Rate	Amount of Registration Fee
Fees to Be Paid	Equity	Common Stock, \$.001 par value per share(2) (3)	457(o)	\$ 28,750,000	—	\$ 28,750,000	0.0000927	\$ 2,665.13
Fees to Be Paid	Equity	Representative's Warrants(4)	457(o)	—	—	—	—	—
Fees to Be Paid	Equity	Shares of Common Stock issuable upon exercise of Representative's Warrants (5)(6)	457(o)	\$ 1,796,875	—	\$ 1,796,875	0.0000927	\$ 166.57
Total Offering Amounts						\$ 30,546,875		\$ 2,831.70
Total Fees Previously Paid								\$ 2,831.70
Total Fee Offsets								—
Net Fee Due								—

- (1) Estimated solely for the purpose of computing the amount of the registration fee pursuant to Rule 457(o) under the Securities Act of 1933, as amended.
- (2) Pursuant to Rule 416, the securities being registered hereunder include such indeterminate number of additional securities as may be issued after the date hereof as a result of stock splits, stock dividends or similar transactions.
- (3) Includes shares of common stock the underwriters have the option to purchase to cover over-allotments, if any.
- (4) No fee required pursuant to Rule 457(g).
- (5) Estimated solely for the purpose of calculating the registration fee pursuant to Rule 457(g) under the Securities Act. We have agreed to issue to the representative of the underwriters warrants to purchase the number of shares of our common stock (the "Representative's Warrants") in the aggregate equal to five percent (5%) of the shares of our common stock to be issued and sold in this offering (including shares issuable upon exercise of the over-allotment option described herein). The Representative's Warrants are exercisable for a price per share equal to 125% of the public offering price. As estimated solely for the purpose of calculating the registration fee pursuant to Rule 457(g), the proposed maximum aggregate offering price of the Representative's Warrants is \$1,796,875, which is equal to 125% of \$1,437,500 (5% of \$28,750,000).
- (6) A fee of \$2,831.70 was previously paid.



EXHIBIT 23.1

Consent of Independent Registered Public Accounting Firm

We hereby consent to the inclusion in this Offering Statement on Form S-1 of our report dated February 2, 2022, which includes an explanatory paragraph as to the Company's ability to continue as a going concern, relating to the financial statements of Forza X1, Inc. as of December 31, 2021 and for the period from inception (October 15, 2021) through December 31, 2021. We also consent to the reference to our firm under the heading "Experts" appearing therein.

Grassi & Co, CPAs, P.C.

Grassi & Co., CPAs, P.C.
Jericho, New York
February 9, 2022
